

OPERATOR'S MANUAL

**ECHO
TRIMMER/
BRUSHCUTTER
SRM-302ADX**

CAUTION

Read Rules for Safe Operation
and Instructions Carefully



898 561-0493 0

INTRODUCTION

The ECHO Trimmer/Brushcutter, model SRM-302ADX, is a lightweight, high performance and gasoline powered rotary trimmer which is designed for brush cutting, weed control and grass trimming in areas which are difficult to control by any other means. The trimmer is equipped with a safety shoulder harness, and the excellent balance characteristics plus the available power, ensures comfortable operation.

A heavy duty nylon cord trimmer head is supplied as standard equipment, and special metal blades for heavy weed and brush clearing are available as optional accessories.

This manual provides the information necessary for assembly, adjustment, operation and maintenance of your unit. A spare parts list is also provided and parts are readily available by following the instructions as detailed on the back page of this book.

SAFETY INSTRUCTIONS

1. Do Not operate the unit when you are fatigued.
2. Do Not operate if other people or animals are in the work area.
3. Do Not operate the unit without the shield correctly in position.
4. Do Not operate in a confined area. Carbon monoxide exhaust gas is highly poisonous.
5. Do Not operate the unit while you are smoking.
6. Always wear eye protection goggles when operating the unit.
7. Always hold the unit firmly with both hands and with fingers and thumbs encircling the handles.
8. Always obey local ordinances regulating the use of internal combustion engines in your area.
9. Always use the cutting attachments as approved and supplied by ECHO Inc. for your unit.
10. Always remain alert when operating the unit to avoid possible injury to yourself and other people.
11. Always wear the shoulder harness when operating the unit.

WARNING-DANGER

1. Do Not smoke while handling gasoline.
2. Do Not refuel a hot engine. Wait until it cools.
3. Do Not overfill the tank. Spilled fuel must be wiped up.
4. Always stop the engine when refueling.
5. Always remove the fuel cap slowly in order to relieve any pressure build up in the tank.
6. Always restart the engine at least 10 feet away from the refueling point.
7. Always store gasoline in an approved container.

CONTENTS

	Page
Safety Instructions	1
Technical Data	2
Nomenclature of Parts	3
Assembling	3
Operation	6
• General Trimming Instructions	7
• Nylon Cord Cutter Head	8
• Steel Blade (Optional supply)	9
Maintenance and Care	11
Trouble Shooting	13
Storage After Use	14
Parts Catalogue	15

TECHNICAL DATA

Dimension	L x W x H	cm (in.)	169 x 60 x 38 (66.5 x 23.6 x 14.9)
Weight		kg (lbs)	6.8: w/o shoulder harness and cutter head (15.0)
Engine	Type Displacement Max revolution Carburetor Ignition Spark plug Starter Clutch	cc (cu.in.) rpm	Air cooled two stroke single cylinder 30.1 (1.83) 9,000 Walbro diaphragm type WA Flywheel magneto: Contact braker point system NGK BM6A Recoil starter Automatic centrifugal clutch
Fuel	Mixing ratio Tank capacity	litre (FL.OZ.US)	Regular grade gasoline 20 parts: ECHO brand motor oil or an air cooled two stroke (engine oil of a reputable brand name) 1 part 0.45 (15.0)
Drive shaft ass'y	Cutter Cutter (optional) Cutter (optional) Gear housing Lubrication Drive shaft Shield		Nylon cord cutter head Eight (8) cutter blade, 8 in. Circular saw, 10 in. 60 degree spur bevel gears, ratio 1:1 (Counter-clockwise) Shell Delpena or good quality lithium grease High tensile solid steel Steel plate mounted on the drive shaft

Technical data subject to change without notice.

NOMENCLATURE OF PARTS

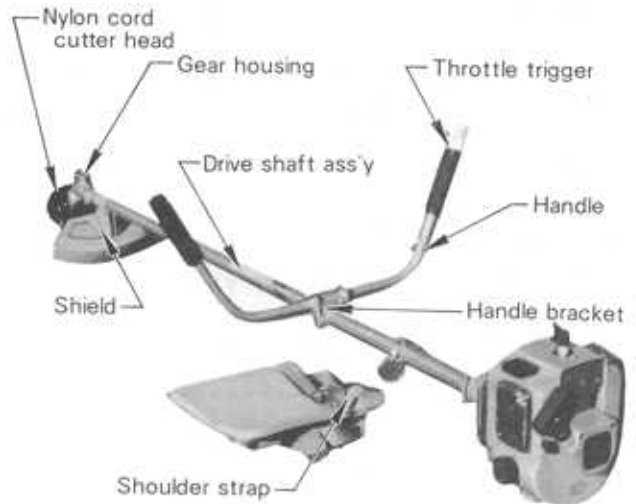
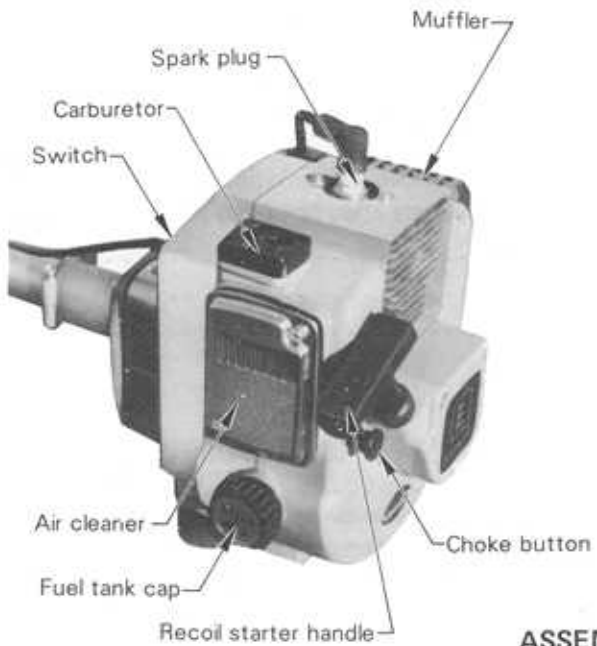

ASSEMBLING

The complete assembly is delivered in two cardboard boxes. Unpack the engine, driving shaft assembly, handle and others.

DRIVE SHAFT

- Stand engine upright on a level floor.
- Loosen two bolts at drive shaft end of the engine.
- Fit drive shaft assembly ensuring that the drive shaft is correctly engaged.
- The line on drive shaft housing must be in contact with the engine.
- Rotate drive shaft housing until gear housing is in line with the engine.
- Tighten both bolts to fasten drive shaft ass'y. Do not over tighten.

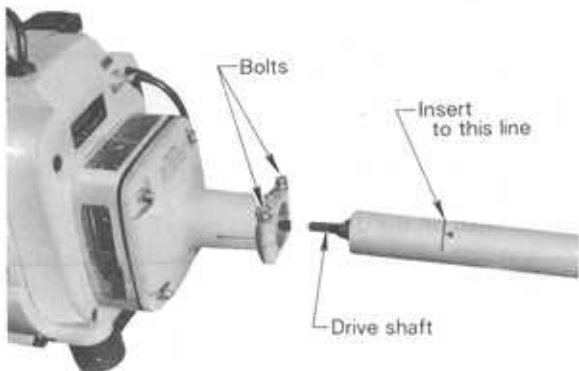

HANDLE

- The handle bracket is fixed on the drive shaft housing at the time of delivery from the plant.
- Assemble the handle and the handle bracket ass'y loosely.
- Adjust the location of the handle and/or handle bracket ass'y to a convenient position.
- Tighten the bolts securely.

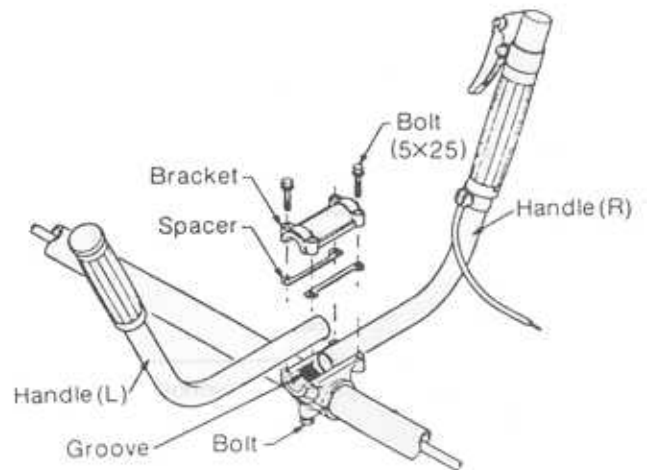

THROTTLE CABLE

- Remove set screws of the throttle trigger.
- Loosen screw of the clamp.
- Feed the throttle cable through the clamp and into elongated slot until the cable extends from end of U-handle as shown.
- Raise throttle trigger until slotted hole is exposed and joint inner throttle cable terminal.
- With the trigger in pressed position, fit setscrew, nut and washer. Depress the trigger and ensure that return spring is anchored against setscrew. Install throttle trigger assembly on the U-handle and tighten setscrew.
- Grasp the trigger until it touches the U-handle grip, and pull the outer cable downward through clamp to remove a slack. Then tighten clamp.
- Fix throttle cable to the drive shaft with clamp of swivel hook.
- Test for satisfactory function of throttle trigger. Make certain that the cutter does not run while trigger is released to idle position. Further, make certain that cutter revolves in enough speed while the trigger is fully depressed.

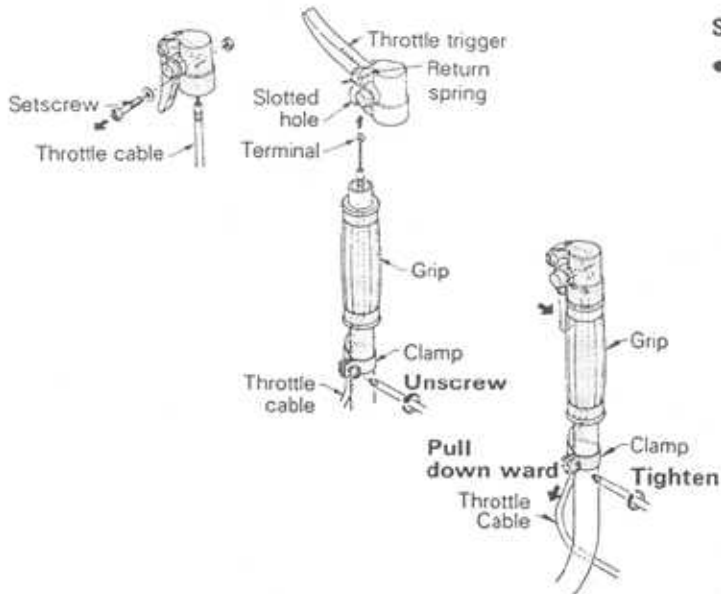

- Fix the throttle cable with clamp to the drive shaft ass'y as shown.

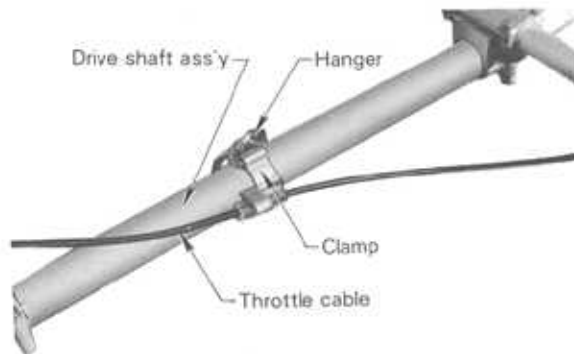

SHIELD

Install the shield to the shield bracket using four screws.



(CAUTION)

Never use the trimmer without shield in correct position.

SHOULDER HARNESS

- Fit shoulder harness to hanger, and adjust length of strap to maintain the cutter head parallel to the ground.

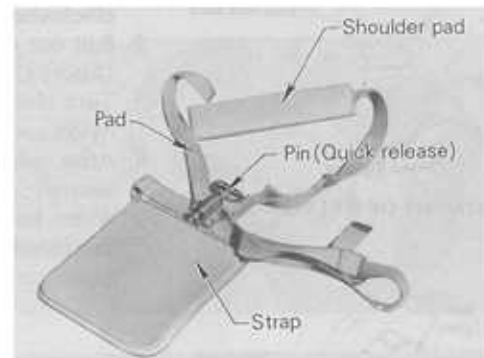

NYLON CORD CUTTER HEAD

Install the nylon cord cutter head as follows.

Before installation, remove split pin, nut and fixing plate (Outer) from the shaft.
(They are not necessary for installing the nylon cord cutter head.)

Use only when metal blade installation.

THE NUT HAS LEFT HAND THREAD.

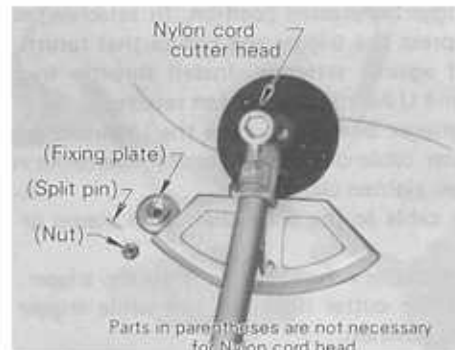
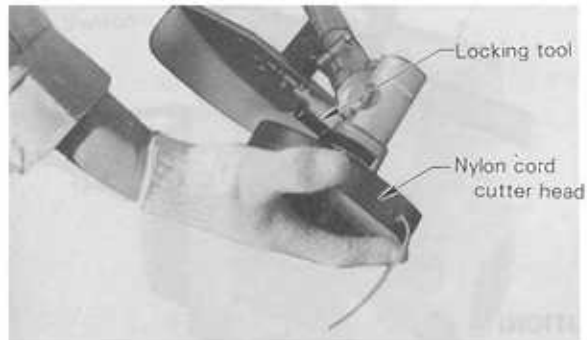

INSTALLATION

- Insert locking tool into the holes of fixing plate (Inner) and gear housing.
- Tighten the cutter head counterclockwise to the shaft.

ASSEMBLING

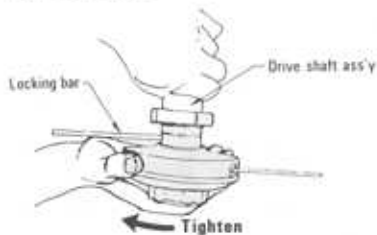

ADJUSTMENT OF NYLON CORD

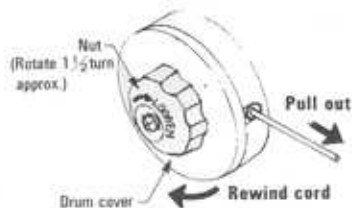

INSTALLING OF NEW NYLON CORD

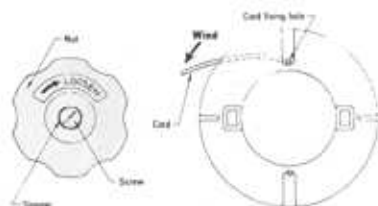

1. Loosen nut 1-1/2 turn approximately clockwise.
2. Pull out nylon cord to a specified length. (Approx. 5 ~ 6 in.: 13 ~ 15 cm)
3. Turn reel drum cover clockwise to rewind nylon cord when necessary.
4. After adjusting the length, tighten nut securely.

* When tip of cord worn out, cracked or shortened, cut the tip and adjust exposed cord length properly as above.

1. Remove screw and stopper. (standard thread)
2. Remove nut. (left hand thread)
3. Take out cord reel and wind nylon cord as shown. Insert cord end into cord fixing hole and start the windings.
4. Assemble the parts backward of above steps 1 to 3.

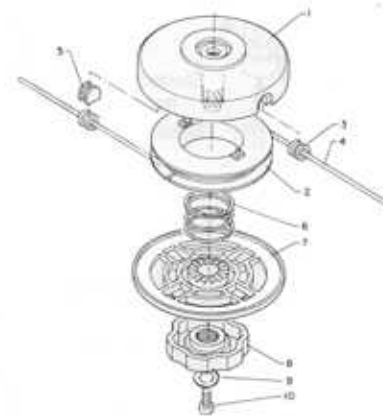

Key No.	Part Name
1.	Drum, cord reel
2.	Cord reel
3.	Cord guide
4.	Nylon cord
5.	Plug cord guide
6.	Spring
7.	Drum cover
8.	Nut
9.	Stopper
10.	Screw

CAUTION: STOP THE ENGINE BEFORE HANDLING THE CUTTER HEAD.

OPERATION

- Check for loose nuts, bolts and screws before using the unit every use.

FUEL

- Fuel used for this model is a mixture of regular grade gasoline and ECHO brand motor oil or an aircooled two stroke engine oil of a reputable brand name.
- Mixture ratio is
Gasoline 20 parts: Oil 1 part.
 - Fuel mixture at a rate other than 20:1 may cause malfunction of the engine.
 - Pour 1/2 of the gasoline into a safe container, add oil and mix thoroughly.
 - Now add the remainder of gasoline and mix again.
 - Do not use motor oil other than that recommended above.
 - Do not mix directly in engine fuel tank.
- After refueling, secure the fuel tank cap and wipe all spilled fuel with a dry cloth.

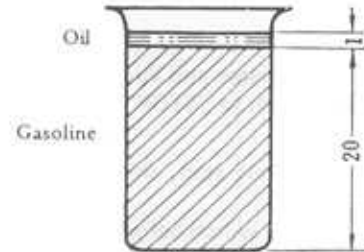

Fuel mix chart

US		IMPERIAL		METRIC	
GAS	OIL	GAS	OIL	GAS	OIL
GAL.	FL. OZ.	GAL.	FL. OZ.	LITERS	C.C.
1	6.4	1	8	4	200
2	12.8	2	16	8	400
5	32.0	5	40	20	1,000 (1 Liter)

STARTING

Before starting the engine, make sure that the cutter head is not contacting anything. Do not allow people into the starting area.

STARTING COLD ENGINE

- Turn switch to START/RUN position as shown.
- Turn choke button to START (Close) position.
- Squeeze throttle trigger and push lock button to lock it.
- Pull starter handle several times until first firing sound.
- Now, turn choke lever to RUN (Open) position, and if necessary, restart the engine again.
- When engine has been started, release throttle triggering by squeezing it immediately.



(CAUTION)

When using throttle lock button, cutter head will go into motion as soon as engine starts.

Use it only when starting cold engine.

- Allow to warm up for a few minutes before using.
- After idling, gradually squeeze throttle trigger and cutter head will start to operate as the engine attains clutch engagement speed of 3000 RPM approximately.



(NOTE)

Recoil starter: Use short pulls – only 1/2–2/3 of starter rope for starting.

Do not allow the starter handle to snap back against the casing.

Always hold the unit firmly.

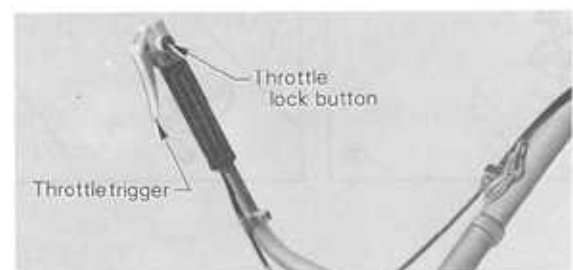

STARTING WARM ENGINE

- When engine is warm, start it by pulling recoil starter rope with switch positioned at START/RUN. (Keep choke button in RUN (Open) position.)
- If engine does not start in a few tries, follow same procedures as to start cold engine.

STOPPING ENGINE

- Release throttle trigger and allow to run at an idle speed.
- Turn ignition switch to "STOP" position.

(NOTE)

When engine does not stop, shift choke button to close position.

Check and repair stop switch before starting the engine again.



GENERAL TRIMMING INSTRUCTIONS

Prior to using your trimmer, familiarize with the safety instructions listed in the Operator's Manual, and all local regulations for the operation of your unit. These instructions and regulations are for the protection of the operator.

For all types of operations, always hold the trimmer securely with both hands, with thumbs and fingers encircling handle and grip.

CAUTION

- Do not allow either people or animals into the work area.
- Always wear safety goggles, gloves, non-skid foot wear and helmet. **DRESS PROPERLY** – Avoid loose clothing.
- Before starting operation, inspect stones or any other foreign object (Can, bottle, steel wire etc.) in the area and remove them.
- When two or more operators are working together, ensure that a safe distance is kept between them.
- Keep both hands on the grips when power is on.
- Engine continues running even when cutter head has stopped due to an excessive load. In such cases, stop the engine and remove the cause of overloaded before again starting the engine and resuming the job.
- When grass or weed have clogged the cutter head affecting normal operation, first, stop the engine and remove them.
- Do not overreach or stand on unstable support.

READ CAREFULLY SAFETY INSTRUCTION (Page 1)

SHOULDER HARNESS

- Put the harness on so that strap is over operators left shoulder and pin and pad hang at right hip.
- Adjust the waist strap so that it fits firmly.
- In an emergency, pull the pin to disconnect the unit from the harness.
- Never use the trimmer without harness.



NYLON CORD CUTTER HEAD

For most cutting and trimming jobs, 13 ~ 15 cm (five ~ six inches) of cord (measured from the edge of the cutting head to the tip of the cutting cord) is recommended. Remember that cutting is done with the tip of the cord.

Do not attempt to cut with the entire length of the cord. This will result in the cord snapping or fraying, thereby reducing the cutting efficiency and also will result in using more cord than necessary.

CUTTING PROCESURES

Place the trimmer with the cutter head facing straight ahead. Always trim from the right to the left tilting the unit slightly to the right allowing the debris to be thrown away from the operator.

(CAUTION)

Letting the cutter head tilt to the left will result in debris being thrown back towards the operator.

(SEE ILLUSTRATIONS A and B)

SCALPING

Scalping is the removal of all vegetation down to the ground. For this operation, tilt the cutter head about 30°. Ensure the head is tilted to the right. (SEE ILLUSTRATION C)

EDGING

Tilt the cutter head to a vertical position. Allow the nylon cord to skim along the edge of the concrete. Adjust the handle bracket so that this can be done with the least amount of effort. (SEE ILLUSTRATION D)

SWEEPING

For clearing driveways, sidewalks, etc. of grass and other debris, tilt the cutter head slightly to the right, then swing from side to side. (SEE ILLUSTRATION E)

(CAUTION)

NEVER attempt sweeping operations when the unit is equipped with optional steel blades.

MOWING

Swing the trimmer from side to side while keeping the cutter head level. During this operation, debris may be thrown in any direction. Safety glasses or a face shield is necessary. (SEE ILLUSTRATION F)

CUTTING PROCESURES

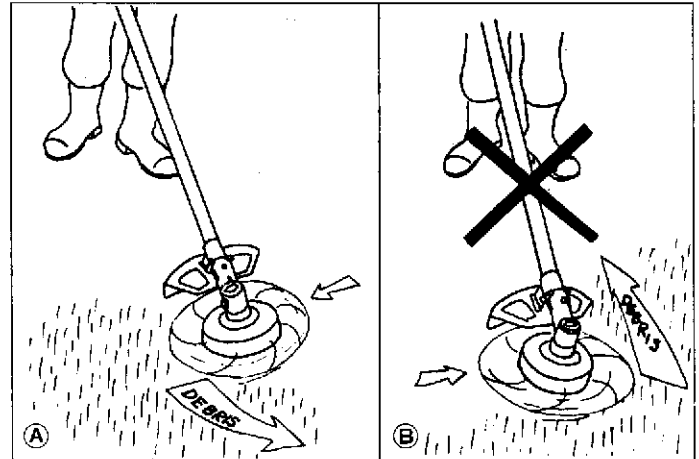

SCALPING

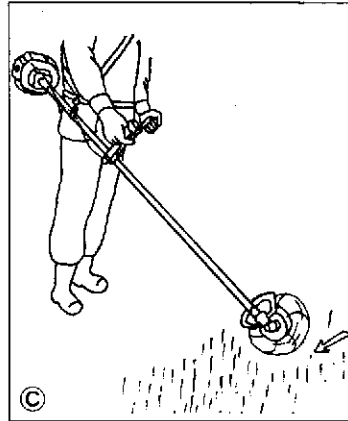

EDGING

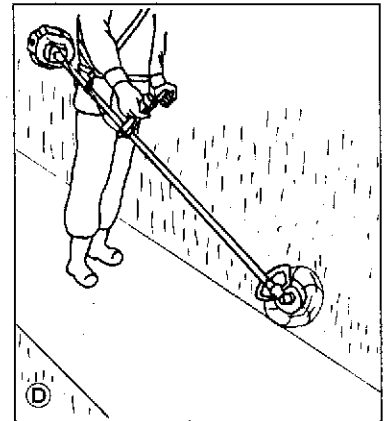

SWEEPING

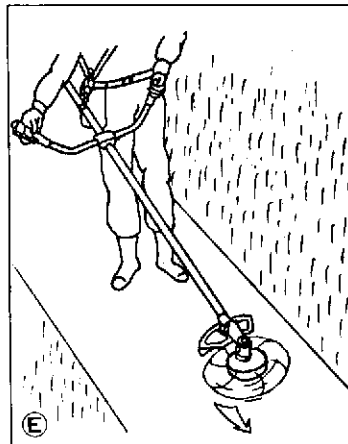

MOWING



STEEL BLADE (Optional Supply)

- This unit is designed for brushcutting and heavy weed trimming.
- Two blades are available as optional supply.
 - 1) Eight (8) cutter blade: 8 in. (200 mm) Diameter (Part No. 696 001-0803 0)
 - : For Weed and grass trimming
 - 2) Circular saw: 10 in. (254 mm) Diameter (Part No. 695 001-0123 0)
 - : For Brush trimming

CUTTER BLADE INSTALLATION

- After fixing the shield assemble the inner blade fixing plate, blade and outer blade fixing plate to the PTO shaft, then fit the nut finger tight.
- Lock the bearing housing and inner blade fixing plate with locking tool and tighten the nut with box wrench. (Counterclockwise)

(NOTE)

The nut is fitted with a left hand thread but must always be secured by a split pin as provided.

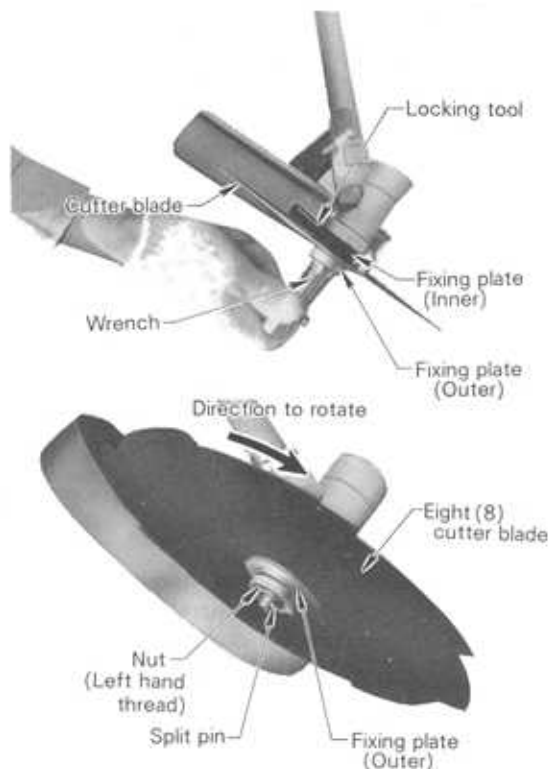
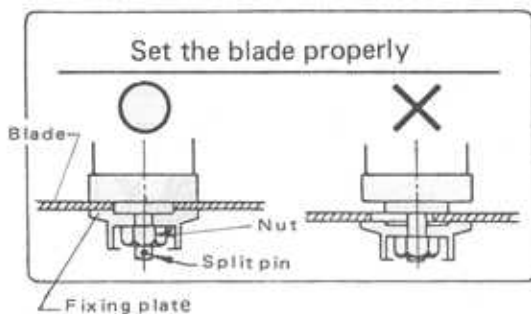

CAUTION

- Always use the correct blade for the job as recommended.
- Be careful not to hit rocks, stones, tree stumps or any foreign object which may damage the blade.
- Do not cut into the ground to avoid dulling the blade.
- Always stop the engine and examine the blade after striking an obstruction do not operate with a blade which is blunt, bent, fractured, or discolored due to overheat.
- In the event, that the blade strikes an obstruction, or is otherwise prevented from rotating in normal operation, the centrifugal clutch will slip to prevent engine damage. In this case, stop the engine free and examine the blade and if in good order, resume operation.
- Should the brushcutter be operated for an extended period in high temperatures, the gear housing may become very hot. If too hot to touch, allow the unit to cool down, check the lubrication as per 'Maintenance' and continue to operate if in order.
- To avoid engine damage, do not run on full throttle without load.
- Do not operate the brushcutter without the harness and debris shield correctly fitted.
- Always inspect the work area and remove any foreign objects.
- Read safety instructions and general trimming instructions (for nylon cord head) in this manual carefully.

HEAVY WEED TRIMMING

(Use eight (8) cutter blade)

- Allow the engine to warm up at a fast idle for a few minutes.
- Increase engine speed as necessary.
- When trimming heavy shrub, brush and/or small trees using the optional eight cutter blade and circular saw, move the cutting blade into the cut, from the right to the left with a slow, deliberate motion.

(CAUTION)

When using optional cutting blades, do not trim from left to right. Such action will force the cutting head to turn from left to right, resulting in a possible loss of control.

- In an emergency, pull out pin of shoulder strap to detach the unit.
- When grass or weeds have clogged the cutter head affecting normal operation, first, stop the engine and then remove it.

Dress properly — Avoid loose clothing.
Always wear safety goggles when cutting trimming.

Before starting up the engine, make sure that the cutter blade is not contacting anything. When two or more operators are working together, ensure that a safe distance is kept between them. Do not allow either people or animals into the work area.

BRUSH TRIMMING

(Use circular saw)

- Proceed exactly as for weed and grass trimming.

SMALL TREES

- The unit will effectively cut small trees up to 3 inches in diameter using the 10 inch diameter new circular saw.
- Before attempting to cut, ensure that the falling tree will fall away from you, and if necessary, tie a rope to the tree and have an assistant pull it in a safe direction.
- Do not attempt to "plunge cut", i.e. using the brush-cutter like an axe. It is not necessary and may cause serious damage to the brushcutter.
- Brace your feet firmly on the ground and cut with the left hand side of the blade.

(CAUTION)

Always cut on full throttle. Never try cutting with a blunt blade.

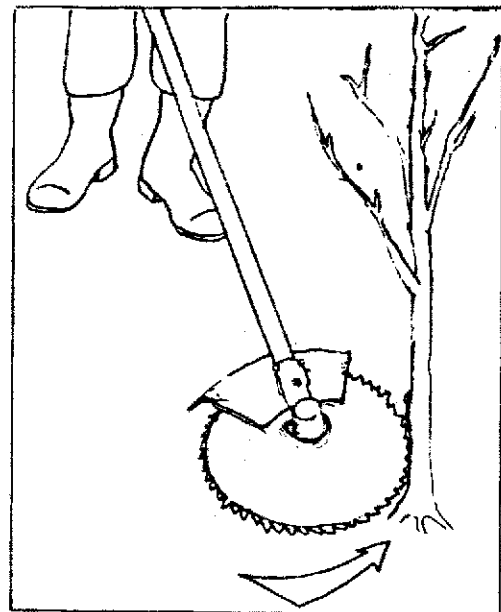

SHARPENING

THE EIGHT (8) CUTTER BLADE

- Use only the blade designated by the manufacturer for this model.
- When crack is noticed on the blade, never use it, but replace with a new one.
- Round the teeth bottom for 1 — 2 mm radius in order to avoid the crack using a round file.
 - Rounded part is not to be sharpened.
 - Sharpen each cutter equally so as to retain the balance of the blade.
 - In sharpening the edge by use of a grinder, do not cool the cutter abruptly by immersing it in water.

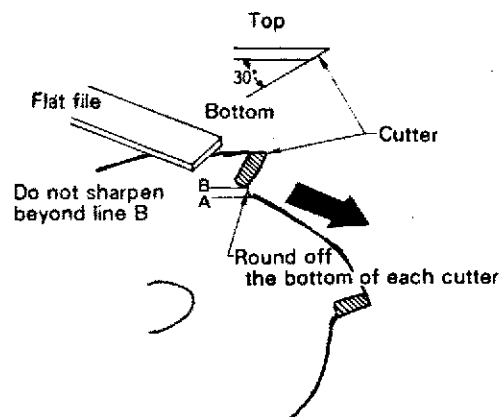

MAINTENANCE AND CARE

= ALWAYS KEEP THE UNIT CLEAN =

AIR FILTER

- Clean before using the unit.
 - Remove air cleaner cover and filter.
 - Brush off dust lightly or wash it in a non-inflammable solvent.
 - When you wash it in a solvent, dry it completely before putting back in place.



GEAR HOUSING

- Remove the bolt every 50 hours and check.
- Replenish as necessary, but do not overfill.
 - Shell delpena, Shell MP or good quality lithium multi grease is recommendable.



SPARK PLUG

- Check periodically.
- Standard spark gap is 0.6–0.7 mm (0.024–0.028 in.).
- Replace if either electrode is worn or if the insulator is fouled by oil or other deposits.
- TORQUE = 145 – 155 kg-cm (125 – 135 in. lb).

CAUTION
Do not over torque.

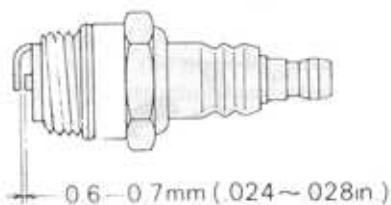

MUFFLER AND EXHAUST PORT

- Clean as necessary.
- Carbon deposit in cylinder exhaust port and muffler will reduce engine output.
 - Muffler can be removed by taking off muffler cover.
 - Be careful not to scratch cylinder or piston when cleaning cylinder exhaust port.

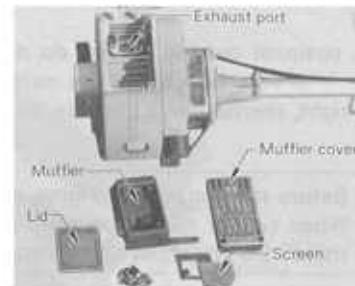

CARBURETOR

● Fuel Feed Adjuster

Do not move the fuel feed adjuster knob. It is regulated before the machine leaves the factory for an optimum fuel feed rate.

In case where the engine does not run with stability, move the fuel feed adjuster knob slightly to stabilize revolution.

(L): Low speed adjuster

(H): High speed adjuster



● Idle Speed Adjust Screw

Turn idle adjust screw clockwise until cutter head begins to turn, then back screw approximately 1/2 turn.



If you have serious trouble with carburetor, we recommend you to see your distributor or dealer.

DUST SEAL SCREEN

- Cylinder is not cooled properly when the dust seal screen is clogged with dust and dirt. This condition can readily cause piston seizure.
- During operation, check the screen from time to time to keep it clean at all times.

CYLINDER FINS

- Dust seal cover is provided for keeping cylinder fins clean. However, through operation for a long time, dust and dirt can collect on the cylinder fins, and this can result in deterioration of cooling effects of fins and can also cause piston seizure. Cylinder fins must be removed and cleaned from time to time.
- Remove four set bolts of the fan cover, disassemble and clean the cylinder fins.

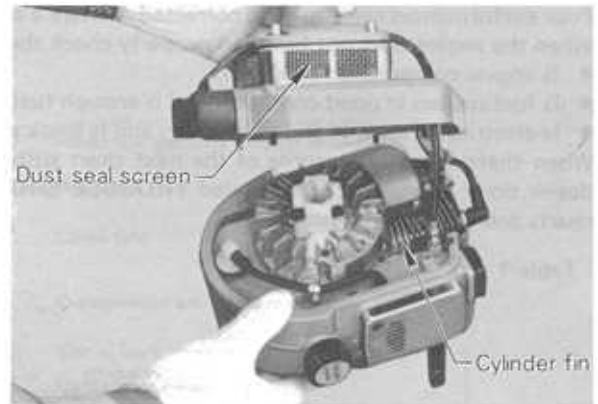

TROUBLE SHOOTING

Poor performance of the engine and/or trimming mechanism can normally be prevented by carefully following the above instructions.

Poor performances can easily be corrected even by a beginner.

When the engine does not function properly check the following three (3) positions first.

- Is engine compression adequate?
- Is fuel system in good condition and is enough fuel being supplied?
- Is electrical system in good condition and is spark plug operating normally?

When there is serious trouble of the next chart with the unit, do not try to repair it yourself but have your distributor or dealer do it for you. For detailed TROUBLE SHOOTING refer to tables 1 and 2. Locate the problem on the following charts and repair as necessary.

Table 1

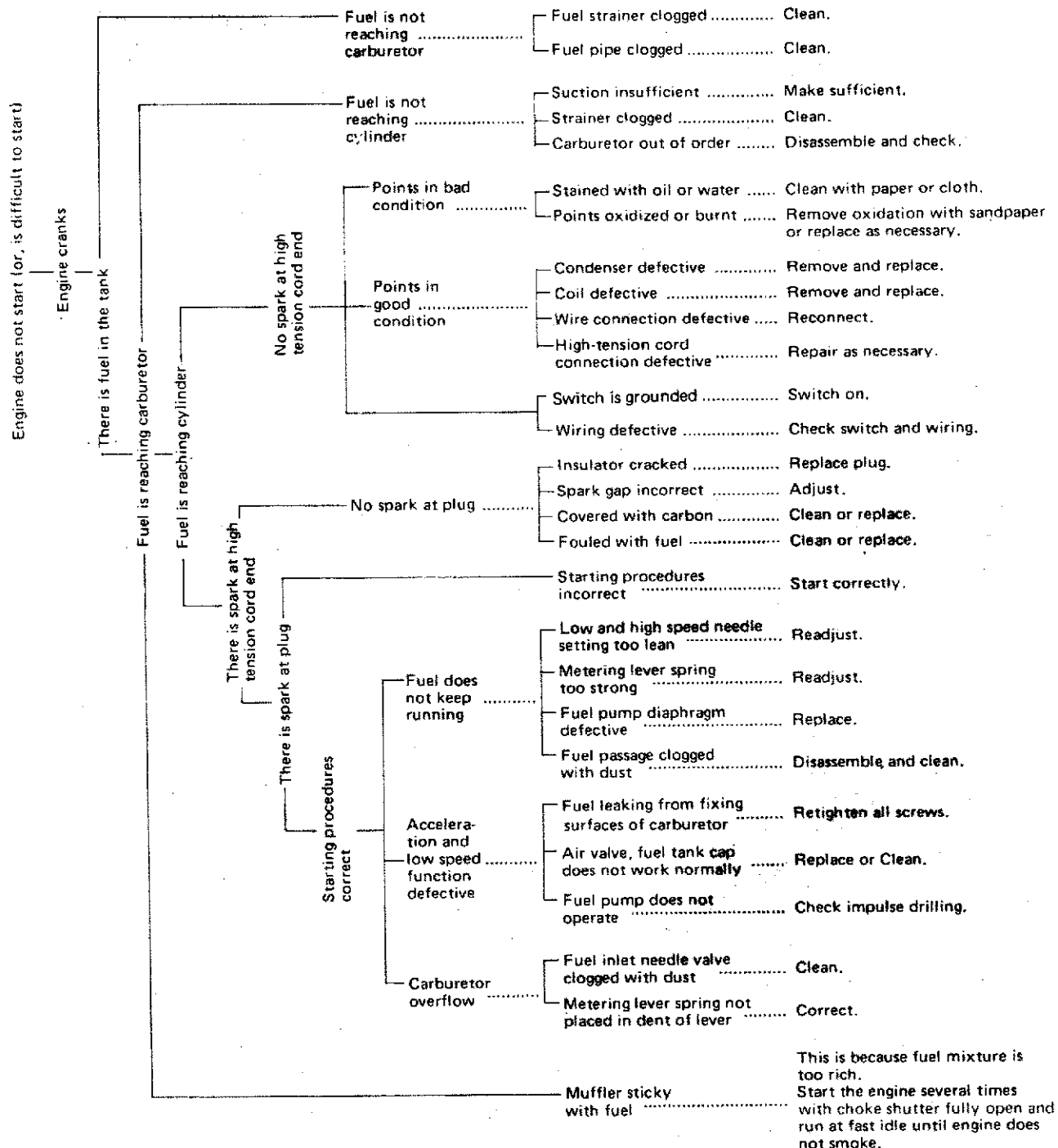
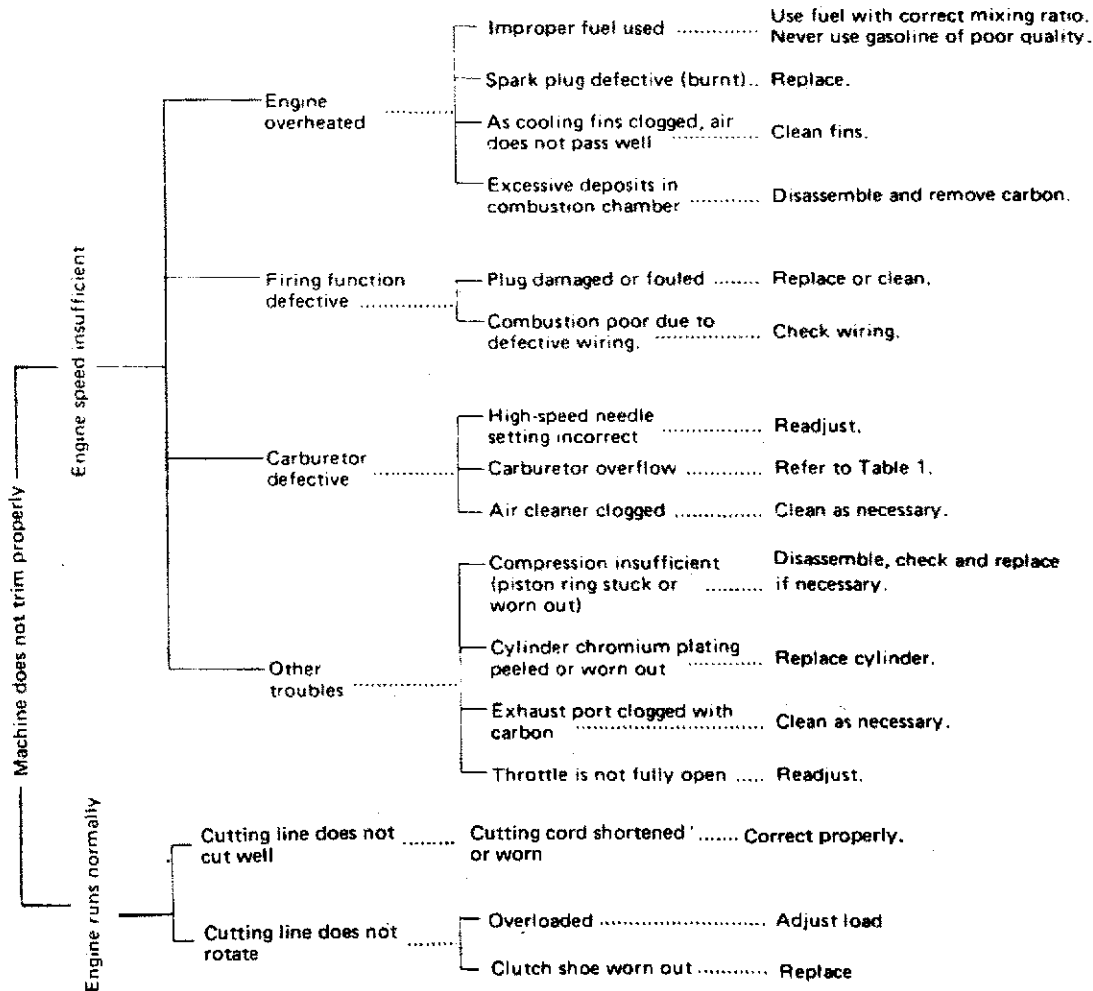

Table 2



STORAGE AFTER USE

- Inspect and adjust every part of the unit.
 - Completely clean every part, and repair, if necessary.
 - Apply thin coating of oil on metal parts to prevent rust.
 - Remove the cutter head, apply sufficient oil coating and wrap up in plastic.
- Drain fuel tank, pull starter handle slowly a few times to drain fuel from carburetor.
- Pour a small amount of clean motor oil into spark plug hole, pull starter handle and then crank the engine until TOP DEAD CENTER.
- Store in a dry area, free from dust.