



Pièces détachées

Motoculteur

KC450F-FW



Yvon Béal 21, Av. de l'agriculture - B.P. 16
Z.I. du Bécot 63014 Clermont-Ferrand Cedex 2
Tél: 04 73 91 92 51 Téléphone: 04 73 90 23 11
www.yvonbeal.fr Email: info@yvonbeal.fr
R.C. B 304 973 886 - SIREN 304 973 886

03-000264-050329

CONTENTS
TABLE DES MATIERES

ENGINE
Moteur

Fig. 1	ENGINE (KF522-A, KF522)	1
	Moteur (KF522-A, KF522)	
Fig. 2	AIR CLEANER	7
	Filtre a air	
Fig. 3	FILTER	8
	Decanteur	
Fig. 4A	CARBURETOR (for KF522-A)	9
	Carburateur (pour KF522-A)	
Fig. 4	CARBURETOR (for KF522)	11
	Carburateur (pour KF522)	
Fig. 5A	MAGNETO (for KF522-A)	13
	Volant magnetique (pour KF522-A)	
Fig. 5	MAGNETO (for KF522)	14
	Volant magnetique (pour KF522)	

NOTE)

** Marked parts in the column remarks, are not always in stock, requiring considerable time for their delivery.*

NOTA)

** Les pièces marquées dans la colonne des remarques, ne sont pas toujours disponibles en stock, et demandent beaucoup de temps avant de pouvoir être livrées.*

Fig. 1

ENGINE (KF522-A, KF522)
Moteur (KF522-A, KF522)

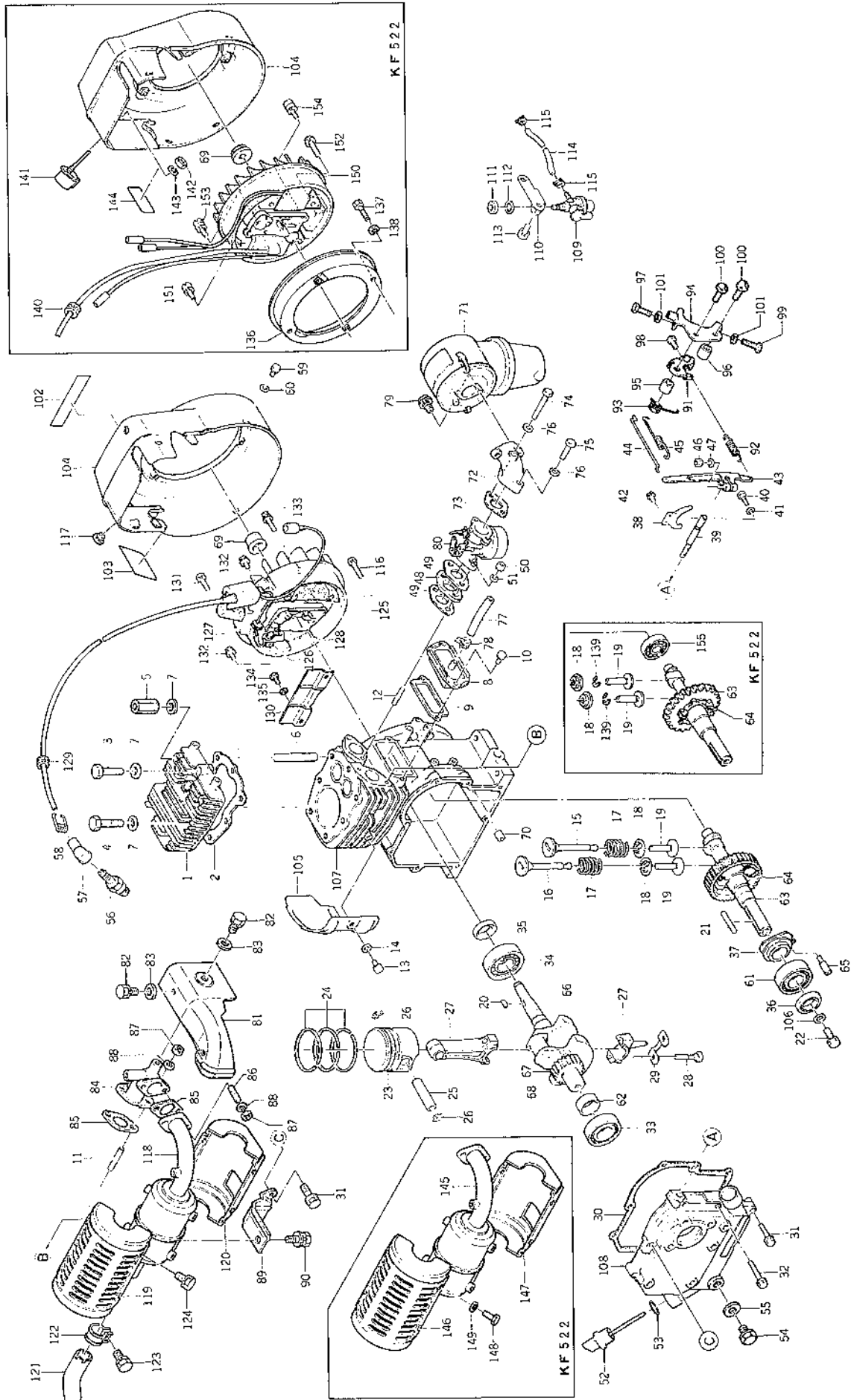

Ref. No. Réf. No.	Part No. Pièces No.	Description Désignation	Q'ty Quant.		Remarks Remarques
			KF 522-A	KF 522	
1	5154-701-111A-X	HEAD, CYL. Culasse	1	1	315470-1111A
2	5142-501-121B-X	GASKET, HEAD Joint de culasse	1	1	314250-1121B
3	5110-G10-40XX-X	BOLT/M10x40 Vis	1	1	110G1040
4	5110-G10-45XX-X	BOLT/M10x45 Vis	4	4	110G1045
5	5182-911-1830-0	NUT, LONG Ecrou colonne	2	2	318291-1183-00
6	5142-501-1850-0	STUD Goujon	2	2	314250-1185-00
7	5410-B10-00XX-X	WASHER, PL/M10 Rondelle	7	7	410B1000
8	5154-701-231A-X	COVER, INSPECTION Couvercle	1		315470-1231A
	5142-501-2310-7	COVER, INSPECTION Couvercle		1	314250-1231-07
9	5142-501-2320-0	GASKET Joint	1	1	314250-1232-00
10	5180-B06-12XX-X	BOLT/M6x12 Vis	2	2	180B0612
11	5171-G08-22XX-X	STUD Goujon	2	2	171G0822
12	5171-G06-22XX-X	STUD Goujon	2	2	171G0622
13	5180-B06-12XX-X	BOLT/M6x12 Vis	1	1	180B0612
14	5411-B06-00XX-X	WASHER, PL/M6 Rondelle	1	1	411B0600
15	5154-002-111A-X	VALVE, INLET Soupape admission	1		315400-2111A
	5142-502-1110-0	VALVE, INLET Soupape admission		1	314250-2111-00
16	5154-702-112A-X	VALVE, EXH. Soupape echappement	1		315470-2112A
	5142-502-1120-0	VALVE, EXH. Soupape echappement		1	314250-2112-00
17	5154-702-113A-X	SPRING, VALVE Ressort, soupape	2		315470-2113A
	5153-702-1130-0	SPRING, VALVE Ressort, soupape		2	315370-2113-00
18	5154-702-116A-X	SEAT, SPRING Siege, ressort	2		315470-2116A
	5135-502-1160-0	SEAT, SPRING Siege, ressort		2	313550-2116-00
19	5142-502-2110-0	TAPPET Poussior	2	2	314250-2211-00
20	5136-502-3710-0	KEY Clavette	1	1	313650-2371-00
21	5511-A05-40XX-X	KEY Clavette	1	1	511A0540
22	5180-B08-25XX-X	BOLT/M8x25 Vis	1	1	180B0825
23	5142-503-1110-6	PISTON Piston	1	1	314250-3111-06
24	5142-503-0100-0	PISTON RING SET Jeu de segments	1	1	314250-3010-00
25	5154-703-121A-X	PIN, PISTON Axe de piston	1		315470-3121A
	5135-503-1210-0	PIN, PISTON Axe de piston		1	313550-3121-00
26	5132-523-1220-0	RING, SNAP Jonc d'arret	2	2	313252-3122-00
27	5142-503-2400-0	ROD, CONN ASSY Tige de bielle	1	1	314250-3240-00
28	5154-703-245A-X	BOLT, CONN ROD Vis	2		315470-3245A
	5135-503-2450-0	BOLT, CONN ROD Vis		2	313550-3245-00
29	5135-503-2480-0	WASHER, LOCK Rondelle d'arret speciale	1	1	313550-3248-00
30	5142-504-1240-0	GASKET Joint	1	1	314250-4124-00
31	5186-B06-32XX-X	BOLT/M6x32 Vis	6	6	186B0632
32	5186-B06-42XX-X	BOLT/M6x42 Vis	2	2	186B0642

Ref. No. RÉF. No.	Part No. Pièces No.	Description Désignation	Qty Quant.		Remarks Remarques
			KF 522-A	KF 522	
33	5601-A62-05XX-X	BEARING, RB/6205 Roulement radial	1	1	601A6205
34	5601-A63-05XX-X	BEARING, RB/6305 Roulement radial	1	1	601A6305
35	5144-014-231B-X	SEAL, OIL Bague d'étancheite	1		314401-4231B
	5142-504-2310-0	SEAL, OIL Bague d'étancheite		1	314250-4231-00
36	5142-504-2350-0	SEAL, OIL Bague d'étancheite	1	1	314250-4235-00
37	5142-505-1210-0	SLEEVE, GOVERNOR Butee de regulateur	1	1	314250-5121-00
38	5142-505-1220-0	TIP, GOVERNOR Embout	1	1	314250-5122-00
39	5142-505-1230-0	SHAFT, GOVERNOR Axe de regulateur	1	1	314250-5123-00
40	5154-705-124A-X	BOLT, SHAFT STOP Vis	1	1	315470-5124A
41	5151-921-2330-0	GASKET Joint	1	1	315192-1233-00
42	5232-B04-06AX-X	SCREW/M4x6 Vis	2	2	232B0406A
43	5142-505-2110-0	ARM, GOVERNOR Bras de regulateur	1	1	314250-5211-00
44	5154-705-231A-X	LINK, GOVERNOR Timonerie de regulateur	1	1	315470-5231A
45	5142-505-2320-0	SPRING, LINK Ressort de timonerie	1	1	314250-5232-00
46	5311-B06-00XX-X	NUT/M6 Ecrou	1	1	311B0600
47	5461-F06-00AX-X	WASHER, SP/M6 Rondelle frein	1	1	461F0600A
48	5151-926-181A-X	INSULATOR, CARBURETOR Isolateur, carburateur	1	1	315192-6181A
49	5154-706-184A-X	GASKET Joint	2	2	315470-6184A
50	5312-B06-00XX-X	NUT/M6 Ecrou	2	2	312B0600
51	5411-B06-00XX-X	WASHER, PL/M6 Rondelle	2	2	411B0600
52	5136-507-411B-X	GAUGE, OIL Jauge d'huile	1	1	313650-7411B
53	5151-927-4320-0	O-RING Joint torique	1	1	315192-7432-00
54	5154-707-441A-X	PLUG, DRAIN Bouchan de vidange	1		315470-7441A
	5182-947-4410-0	PLUG, DRAIN Bouchan de vidange		1	318294-7441-00
55	5154-707-214A-X	GASKET Joint	1		315470-7214A
	5312-017-2140-0	GASKET Joint		1	331201-7214-00
56	5122-008-4100-0	PLUG, SPARK/NGK B6HS Bougie d'allumage	1	1	312200-8410-00
57	5172-708-418A-X	CAP, PLUG Contacteur de bougie	1	1	317270-8418A
58	5172-708-419A-X	SPRING Frein	1	1	317270-8419A
59	5180-B06-12XX-X	BOLT/M6x12 Vis	4	4	180B0612
60	5411-B06-00XX-X	WASHER, PL/M6 Rondelle	4	4	411B0600
61	5601-A62-05XX-X	BEARING, RB/6205 Roulement radial	1	1	601A6205
62	5154-703-261A-X	COLLAR, CRANK SHAFT Coussinet, vilebrequin	1		315470-3261A
	5142-503-2610-0	COLLAR, CRANK SHAFT Coussinet, vilebrequin		1	314250-3261-00
63	5154-702-310A-X	CAM GEAR ASSY Arbre a cames	1		315470-2310A
	5142-502-3100-0	CAM GEAR ASSY Arbre a cames		1	314250-2310-00
64	5142-015-1100-0	GOVERNOR ASSY Regulateur	1	1	314201-5110-00
65	5135-015-1150-0	PIN, GUIDE Goupille	1	1	313501-5115-00
66	5154-703-210C-X	CRANK SHAFT ASSY Vilebrequin	1		315470-3210C

Ref. No. Réf. No.	Part No. Pièces No.	Description Désignation	Q'ty Quant.		Remarks Remarques	
			KF 522-A	KF 522		
66	5153-703-2100-0	CRANK SHAFT ASSY Vilebrequin		1	315370-3210-00	
67	5142-503-2170-0	GEAR, CRANK Engrenage	1	1	314250-3217-00	
68	5132-522-3710-0	KEY Clavette	1	1	313252-2371-00	
69	5154-703-481A-X	NUT Erou	1		315470-3481A	
	5132-523-4810-0	NUT Erou		1	313252-3481-00	
70	5552-B10-12XX-X	PIN, DOWEL Goupille elastique	2	2	552B1012	
71	5153-961-3100-0	AIR CLEANER ASSY Filtre a air	1	1	315396-1310-00	See Fig. 2 Voir Fig. 2
72	5142-921-3310-0	PIPE, INLET Tuyau d'aspiration	1	1	314292-1331-00	
73	5142-511-3320-0	GASKET Joint	1	1	314251-1332-00	
74	5142-921-3160-0	BOLT Vis	1	1	314292-1316-00	
75	5142-921-3260-0	BOLT Vis	1	1	314292-1326-00	
76	5164-421-3810-0	WASHER Rondelle	2		316442-1381-00	
	5142-111-3810-0	WASHER Rondelle		2	314211-1381-00	
77	5702-A07-1000-X	TUBE, RUBBER/ø=135mm Conduit	1	1	702A071000	
78	5136-791-5320-0	CLIP Collier	1	1	313679-1532-00	
79	5232-B05-10AX-X	SCREW/M5×10 Vis	2	2	232B0510A	
80	5154-706-100E-X	CARBURETOR ASSY Carburateur	1		315470-6100E	See Fig. 4A Voir Fig. 4A
	5142-926-1000-0	CARBURETOR ASSY Carburateur		1	314292-6100-00	See Fig. 4 Voir Fig. 4
81	5153-811-444B-X	COVER, EXH. PIPE Protege pipe	1		315381-1444B	
	5153-811-4440-0	COVER, EXH. PIPE Protege pipe		1	315381-1444-00	
82	5180-B06-10XX-X	BOLT/M6×10 Vis	3	3	180B0610	
83	5411-B06-00XX-X	WASHER, PL/M6 Rondelle	3	3	411B0600	
84	5153-811-441B-X	PIPE, EXH. Tuyau d'echappement	1	1	315381-1441B	
85	5142-501-4420-0	GASKET Joint	2	2	314250-1442-00	
86	5171-G08-18XX-X	STUD Goujon	2	2	171G0818	
87	5311-R08-00AX-X	NUT/M8 Erou	4	4	311R0800A	
88	5461-F08-00XX-X	WASHER, SP/M8 Rondelle frein	4	5	461F0800	
89	5153-921-4450-0	STAY, MUFFLER Bride silencieux	1	1	315392-1445-00	
90	5182-B08-14XX-X	BOLT/M8×14 Vis	1	1	182B0814	
91	5142-925-3100-0	CONTROL LEVER ASSY Lever	1	1	314292-5310-00	
92	5136-505-3140-0	SPRING, GOVERNOR Ressort de regulateur	1	1	313650-5314-00	
93	5136-905-3170-0	SPRING, RETURN Ressort der	1	1	313690-5317-00	
94	5142-925-3310-0	PLATE, CONTROL Embase	1	1	314292-5331-00	
95	5182-905-3320-0	COLLAR, CONTROL PLATE Coussinet, embase	1	1	318290-5332-00	
96	5182-905-3330-0	COLLAR, CONTROL PLATE Coussinet, embase	1	1	318290-5333-00	
97	5112-B05-08XX-X	BOLT/M5×8 Vis	1		112B0508	
	5136-905-3820-0	BOLT Vis		1	313690-5382-00	
98	5136-405-3820-0	BOLT Vis	1		313640-5382-00	
	5110-B05-08AX-X	BOLT/M5×8 Vis		1	110B0508A	

Ref. No. Réf. No.	Part No. Pièces No.	Description Désignation	Qty Quant.		Remarks Remarques
			KP 522-A	KP 522	
99	5136-405-3820-0	BOLT	1		313640-5382-00
		Vis			
	5110-B06-25XX-X	BOLT/M6×25	1		110B0625
		Vis			
100	5242-B06-28XX-X	SCREW/M6×28	2	2	242B0628
		Vis			
101	5312-B06-00XX-X	NUT/M6	2	2	312B0600
		Ecrou			
102	5154-870-811A-X	LABEL, MARK	1		315487-0811A ※
		Etiquette			
	5136-930-8110-0	LABEL, MARK	1		313693-0811-00 ※
		Etiquette			
103	5154-830-851A-X	LABEL	1		315483-0851A ※
		Etiquette			
	5142-920-8130-0	LABEL	1		314292-0813-00 ※
		Etiquette			
104	5154-961-611B-X	CASE, SPIRAL	1		315496-1611B
		Carenage de volute			
	5153-921-6110-0	CASE, SPIRAL	1		315392-1611-00
		Carenage de volute			
105	5153-901-6320-0	COVER, CYL.	1		315390-1632-00
		Couvre culasse			
	5153-921-6320-0	COVER, CYL.	1		315392-1632-00
		Couvre culasse			
106	5142-922-3830-0	WASHER	1	1	314292-2383-00
		Rondelle			
107	5154-814-110B-X	CRANK CASE ASSY	1		315481-4110B
		Carter moteur			
	5153-904-1100-1	CRANK CASE ASSY	1		315390-4110-01
		Carter moteur			
108	5154-814-121A-X	SIDE BASE	1		315481-4121A
		Flasque			
	5142-924-1210-0	SIDE BASE	1		314292-4121-00
		Flasque			
109	5142-926-5100-2	FILTER ASSY	1	1	314292-6510-02
		Decanteur			
110	5164-306-561A-X	BRACKET, FILTER	1		316430-6561A
		Support, decanteur			
	5142-926-5610-0	BRACKET, FILTER	1		314292-6561-00
		Support, decanteur			
111	5136-506-5270-0	NUT	1	1	313650-6527-00
		Ecrou			
112	5463-H10-00XX-X	WASHER, TOOTHED	1	1	463H1000
		Rondelle			
113	5180-B08-14XX-X	BOLT/M8×14	2	2	180B0814
		Vis			
114	5702-A04-1000-X	TUBE, RUBBER/ℓ=310mm	1		702A041000
		Conduit			
	5142-506-8110-0	PIPE, FUEL	1		314250-6811-00
		Pipe			
115	5136-796-8120-0	CLIP	2	2	313679-6812-00
		Collier			
116	5180-B06-30XX-X	BOLT/M6×30	2		180B0630
		Vis			
117	5126-931-6710-0	KNOCK, RUBBER	1		312693-1671-00
		Manche, gomme			
118	5154-961-400A-X	MUFFLER ASSY	1		315496-1400A
		Silencieux			
119	5153-811-4310-0	COVER, MUFFLER	1		315381-1431-00
		Protecteur			
120	5153-811-432A-X	COVER, MUFFLER	1		315381-1432A
		Protecteur			
121	5136-411-449A-X	PIPE, TAIL	1		313641-1449A
		Tube d'échappement			
122	5136-881-453A-X	BAND	1		313688-1453A
		Attache			
123	5180-B06-14XX-X	BOLT/M6×14	1		180B0614
		Vis			
124	5180-B06-10XX-X	BOLT/M6×10	4		180B0610
		Vis			
125	5154-638-110B-X	MAGNETO ASSY	1		315463-8110B
		Volant magnetique			
126	5144-018-129A-X	CLAMP	1		314401-8129A
		Collier			
127	5144-018-164A-X	GROMMET	1		314401-8164A
		Bougie			
128	5154-708-164A-X	GROMMET	1		315470-8164A
		Bougie			

See Fig. 3
Voir Fig. 3

See Fig. 5A
Voir Fig. 5A

Ref. No. Réf. No.	Part No. Pièces No.	Description Désignation	Q'ty Quant.		Remarks Remarques
			KF1	KF2	
129	5136-468-1640-0	GROMMET Bougie	1		313646-8164-00
130	5154-708-468B-X	PLATE Plaque	1		315470-8468B
131	5180-B05-20XX-X	BOLT/M5x20 Vis	2		18080520
132	5242-B04-10AX-X	SCREW/M4x10 Vis	2		242B0410A
133	5242-B04-20XX-X	SCREW/M4x20 Vis	2		242B0420
134	5112-B05-08XX-X	BOLT/M5x8 Vis	2		112B0508
135	5461-F05-00AX-X	WASHER, SP/M5 Rondelle frein	2		461F0500A
136	5153-701-6120-0	CASE, SPIRAL (2) Carenage de volute	1		315370-1612-00
137	5110-B06-12XX-X	BOLT/M6x12 Vis	4		110B0612
138	5461-F06-00AX-X	WASHER, SP/M6 Rondelle frein	4		461F0600A
139	5135-502-1150-0	COLLET Bague	2		313550-2115-00
140	5142-508-1640-0	GROMMET Bougie	1		314250-8164-00
141	5143-108-5110-0	SWITCH, STOP Interrupteur	1		314310-8511-00
142	5312-B08-00AX-X	NUT/M8 Ecrou	1		312B0800A
143	5461-F08-00XX-X	WASHER, SP/M8 Rondelle frein	1		461F0800
144	5136-930-8510-0	LABEL, CAUTION Etiquette	1		313693-0851-00 *
145	5153-811-4000-0	MUFFLER ASSY Silencieux	1		315381-1400-00
146	5153-811-4310-0	COVER, MUFFLER Protecteur	1		315381-1431-00
147	5153-811-4320-0	COVER, MUFFLER Protecteur	1		315381-1432-00
148	5110-B06-10XX-X	BOLT/M6x10 Vis	4		110B0610
149	5461-F06-00AX-X	WASHER, SP/M6 Rondelle frein	4		461F0600A
150	5153-728-1100-2	MAGNETO ASSY Volant magnetique	1		315372-8110-02
151	5229-B06-25XX-X	SCREW/M6x25 Vis	2		229B0625
152	5229-B06-30XX-X	SCREW/M6x30 Vis	2		229B0630
153	5231-B04-10AX-X	SCREW/M4x10 Vis	1		231B0410A
154	5229-B04-12AX-X	SCREW/M4x12 Vis	2		229B0412A
155	5601-A62-02XX-X	BEARING, RB/6202 Roulement radial	1		601A6202
ACCESSORY Accessoire					
	5154-810-900A-X	TOOL ASSY Outillage complet	1		315481-0900A *
	5182-900-9150-0	OPEN END WRENCH/10x13 Cle tube	1		318290-0915-00 *
	5182-900-9310-0	SOCKET WRENCH/10x13 Cle a pipe	1		318290-0931-00 *
	5151-200-9340-0	SOCKET WRENCH/17x21 Cle a pipe	1		315120-0934-00 *
	5142-920-9000-0	TOOL ASSY Outillage complet	1		314292-0900-00 *
	5182-900-9150-0	OPEN END WRENCH/10x13 Cle tube	1		318290-0915-00 *
	5182-900-9310-0	SOCKET WRENCH/10x13 Cle a pipe	1		318290-0931-00 *
	5151-200-9340-0	SOCKET WRENCH/17x21 Cle a pipe	1		315120-0934-00 *
	5112-200-9720-0	GAUGE, THICKNESS Jauge d'epaisseur	1		311220-0972-00 *

See Fig. 5
Voir Fig. 5

Fig. 2 AIR CLEANER
Filtre a air

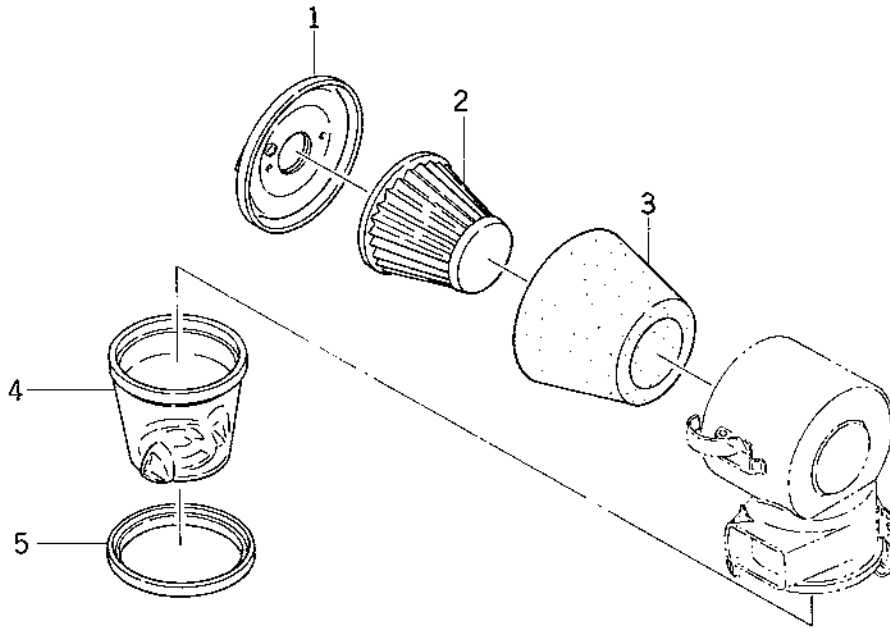

Ref. No. Réf. No.	Part No. Pièces No.	Description Désignation	Q'ty Quant.		Remarks Remarques
			KF 522-A	KF 522	
	5153-961-3100-0	AIR CLEANER ASSY Filtre a air	1	1	315396-1310-00
2- 1	5142-921-3140-0	•PLATE, AIR CLEANER Plaque	1	1	314292-1314-00
2- 2	5142-921-3120-0	•ELEMENT Cartouche	1	1	314292-1312-00
2- 3	5142-921-3130-0	•ELEMENT Cartouche	1	1	314292-1313-00
2- 4	5142-921-3200-0	•CHAMBER, DUST Bol	1	1	314292-1320-00
2- 5	5142-921-3190-0	•RING AIR CLEANER Ecrou annulaire	1	1	314292-1319-00

Fig. 3 FILTER
Decanteur

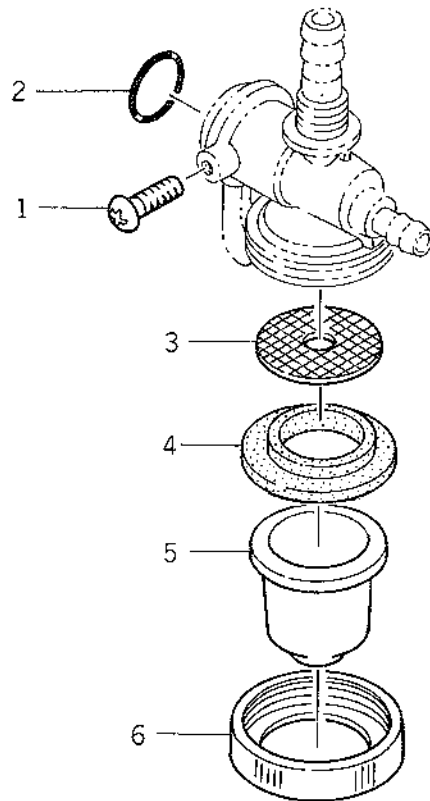

Ref. No. Réf. No.	Part No. Pièces No.	Description Désignation	Q'ty Quant.		Remarks Remarques
			KF 522-A	KF 522	
	5142-926-5100-2	FILTER ASSY Decanteur	1	1	314292-6510-02
3- 1	5136-506-5170-0	•SCREW Vis	1	1	313650-6517-00
3- 2	5136-506-5120-0	•O-RING Joint torique	1	1	313650-6512-00
3- 3	5136-506-5190-0	•STRAINER FILTER Filtre	1	1	313650-6519-00
3- 4	5136-506-5180-2	•GASKET Joint	1	1	313650-6518-02
3- 5	5142-926-5210-0	•POT, FILTER Cuve	1	1	314292-6521-00
3- 6	5136-506-5220-0	•NUT, RING Ecrou annulaire	1	1	313650-6522-00

Fig. 4A CARBURETOR (for KF522-A)
Carburateur (pour KF522-A)

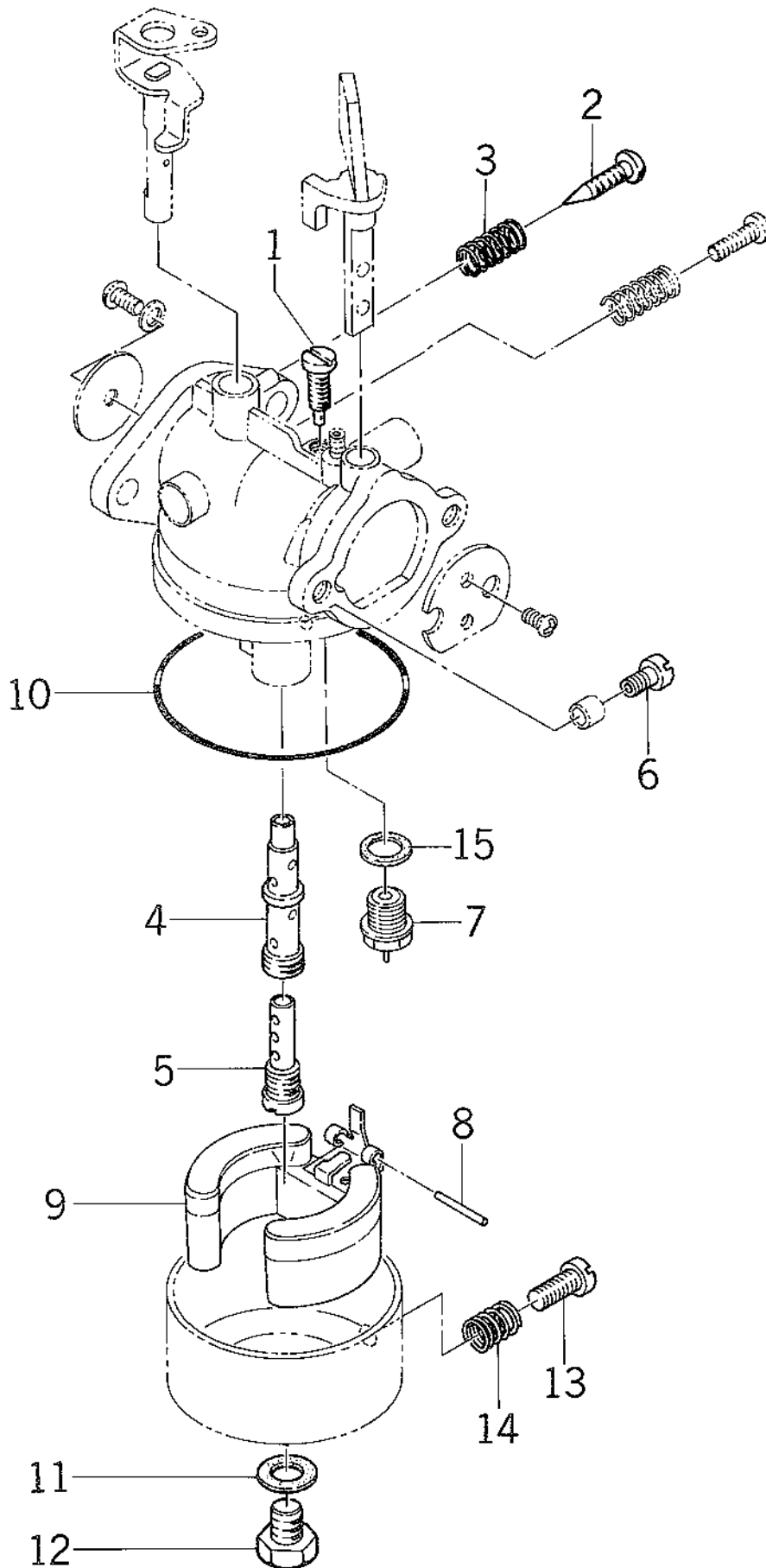

Ref. No. Réf. No.	Part No. Pièces No.	Description Désignation	Qty Quant.		Remarks Remarques
			KF 522-A	KF 522	
	5154-706-100E-X	CARBURETOR ASSY Carburateur	1		315470-6100E
4A- 1	5166-706-1120-0	•JET, PILOT/#42.5 Buse, pilote	1		316670-6112-00
4A- 2	5136-506-1140-0	•SCREW, PILOT Vis, pilote	1		313650-6114-00
4A- 3	5127-506-1160-0	•SPRING Ressort	1		312750-6116-00
4A- 4	5136-506-1290-0	•NOZZLE, MAIN Buse	1		313650-6129-00
4A- 5	5136-506-1060-0	•PIPE, BLEED Tayau, purgeur	1		313650-6106-00
4A- 6	5142-516-1320-0	•JET, MAIN/#82.5 Gicleur principal	1		314251-6132-00
4A- 7	5136-506-1200-0	•NEEDLE VALVE ASSY Pointeau complet	1		313650-6120-00
4A- 8	5136-506-1270-0	•PIN, FLOAT Axe de flotteur	1		313650-6127-00
4A- 9	5136-506-1260-0	•FLOAT Flotteur	1		313650-6126-00
4A-10	5136-506-1280-0	•GASKET Joint	1		313650-6128-00
4A-11	5181-906-1590-0	•WASHER Rondelle	1		318190-6159-00
4A-12	5136-506-1430-0	•PLUG, DRAIN Bouchon de vidange	1		313650-6143-00
4A-13	5127-596-1330-0	•SCREW, DRAIN Vis de vidange	1		312759-6133-00
4A-14	5127-596-1160-0	•SPRING Ressort	1		312759-6116-00
4A-15	5136-506-1190-0	•GASKET Joint	1		313650-6119-00

Fig. 4 CARBURETOR (for KF522)
Carburateur (pour KF522)

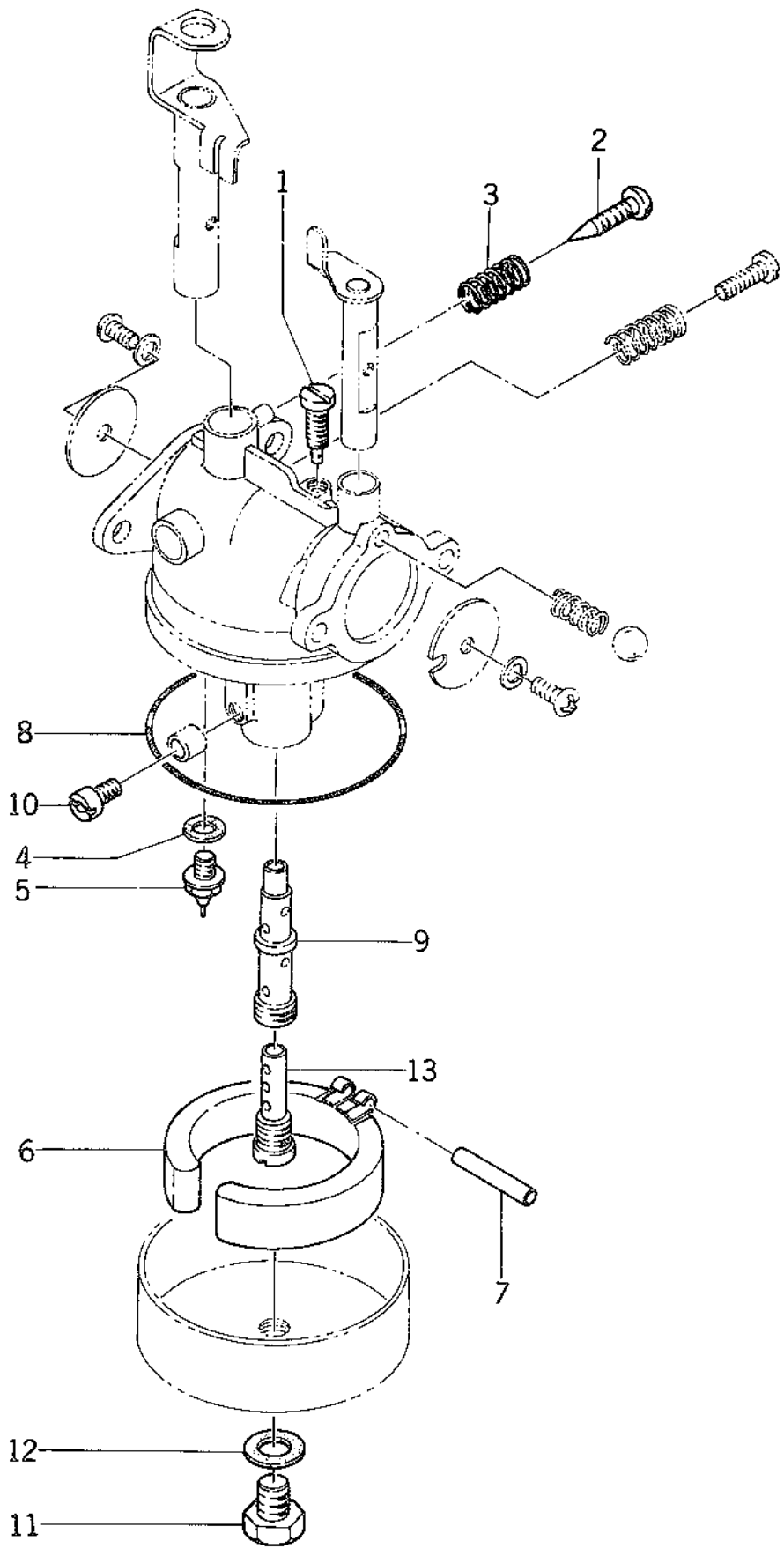

Ref. No. Réf. No.	Part No. Pièces No.	Description Désignation	Q'ty Quant.		Remarks Remarques
			KF 522-A	KF 522	
	5142-926-1000-0	CARBURETOR ASSY Carburateur		1	314292-6100-00
4- 1	5136-506-1120-0	•JET, PILOT/#45 Buse, pilote		1	313650-6112-00
4- 2	5136-506-1140-0	•SCREW, PILOT Vis. pilote		1	313650-6114-00
4- 3	5136-506-1160-0	•SPRING Ressort		1	313650-6116-00
4- 4	5136-506-1190-0	•GASKET Joint		1	313650-6119-00
4- 5	5136-506-1200-0	•NEEDLE VALVE ASSY Pointeau complet		1	313650-6120-00
4- 6	5136-506-1260-0	•FLOAT Flotteur		1	313650-6126-00
4- 7	5136-506-1270-0	•PIN, FLOAT Axe de flotteur		1	313650-6127-00
4- 8	5136-506-1280-0	•GASKET Joint		1	313650-6128-00
4- 9	5136-506-1290-0	•NOZZLE, MAIN Buse		1	313650-6129-00
4-10	5142-516-1320-0	•JET, MAIN/#82.5 Gicleur principal		1	314251-6132-00
4-11	5136-506-1430-0	•PLUG, DRAIN Bouchon de vidange		1	313650-6143-00
4-12	5181-906-1590-0	•WASHER Rondelle		1	318190-6159-00
4-13	5136-506-1060-0	•PIPE, BLEED Tayau, purgeur		1	313650-6106-00

Fig. 5A MAGNETO (for KF522-A)
Volant magnetique (pour KF522-A)

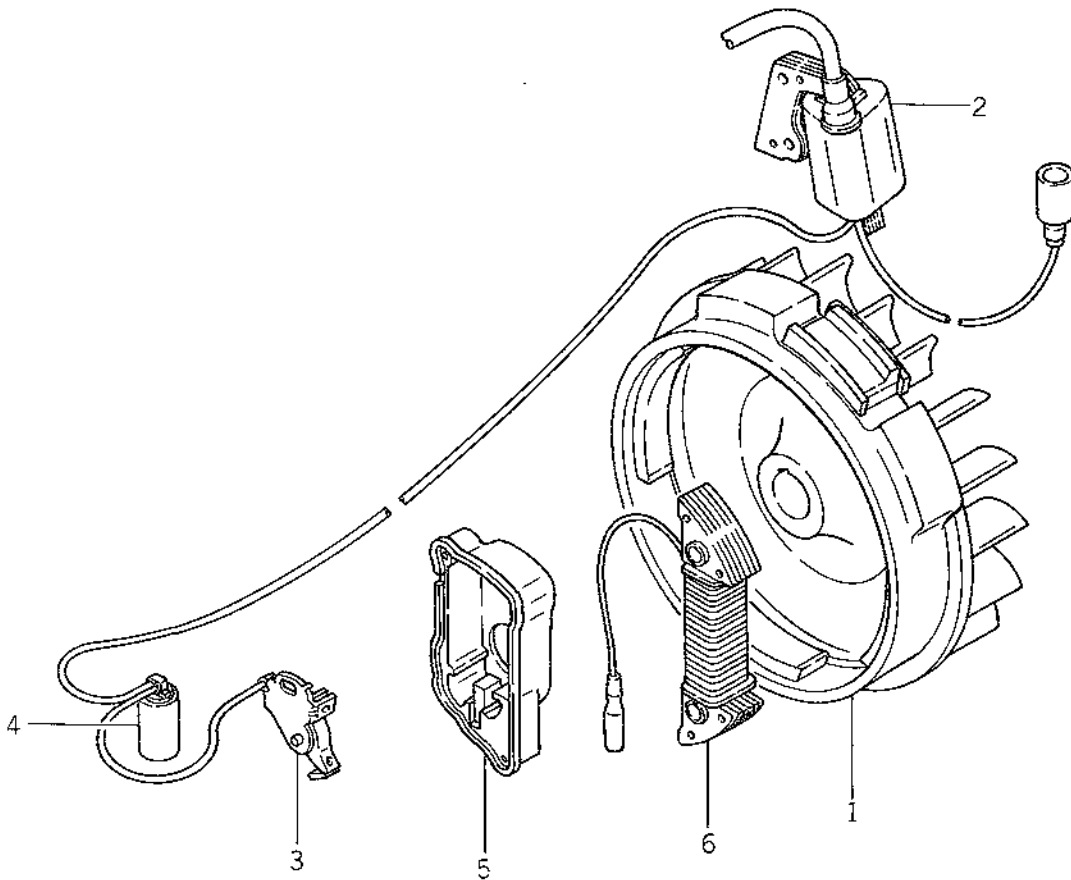

Ref. No. Réf. No.	Part No. Pièces No.	Description Désignation	Q'ty Quant.		Remarks Remarques
			KF 522-A	KF 522	
	5154-638-110B-X	MAGNETO ASSY Volant magnetique	1		315463-8110B
5A- 1	5154-638-111A-X	•FLYWHEEL Volant d'inertie	1		315463-8111A
5A- 2	5154-708-123A-X	•COIL, IGNITION Bobine d'induction	1		315470-8123A
5A- 3	5153-208-4400-0	•BREAKER, CONTACT Rupteur	1		315320-8440-00
5A- 4	5154-708-436A-X	•CONDENSER Condensateur	1		315470-8436A
5A- 5	5154-708-439A-X	•COVER, BREAKER Couvercle de rupteur	1		315470-8439A
5A- 6	5154-428-124B-X	•COIL, LIGHTING Bobine d'eclairage	1		315442-8124B

Fig. 5 MAGNETO (for KF522)
Volant magnetique (pour KF522)

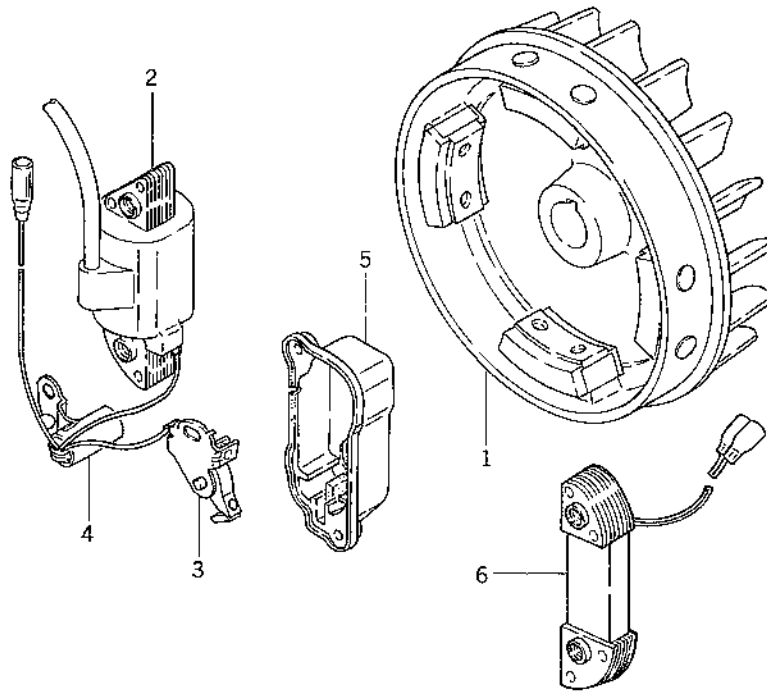

Ref. No. Réf. No.	Part No. Pièces No.	Description Désignation	Q'ty Quant.		Remarks Remarques
			KF 522-A	KF 522	
	5153-728-1100-2	MAGNETO ASSY Volant magnetique		1	315372-8110-02
5- 1	5153-728-1110-0	◦FLYWHEEL Volant d'inertie		1	315372-8111-00
5- 2	5153-208-1230-2	◦COIL, IGNITION Bobine d'induction		1	315320-8123-02
5- 3	5153-208-4400-0	◦BREAKER, CONTACT Rupteur		1	315320-8440-00
5- 4	5153-208-4360-0	◦CONDENCER Condensateur		1	315320-8436-00
5- 5	5153-708-4390-2	◦COVER, BREAKER Couvercle de rupteur		1	315370-8439-02
5- 6	5153-728-1240-0	◦COIL, LIGHTING Bobine d'eclairage		1	315372-8124-00

C H A S S I S

CONTENTS

ENGINE

		PAGE
Fig. 1	ENGINE Moteur	1
Fig. 2	AIR CLEANER Filtre a air	11
Fig. 3	FUEL FILTER Decanteur	13
Fig. 4	CARBURETOR Carburateur	15
Fig. 5	MAGNETO Decanteur	17

CHASSIS

Fig. 6	FRONT FRAME (For KC350 No. 1-6750) Longeron	21
Fig. 7	FRONT FRAME (No. 6751-) (FNo. 100001~) Longeron	25
Fig. 8	TRANSMISSION GEAR CASE (For KC350) Boitier de reducteur	29
Fig. 9	TRANSMISSION GEAR CASE (For KC350F) Boitier de reducteur	31
Fig. 10	TRANSMISSION GEAR Reducteur	33
Fig. 11	SHIFTER Fourchettes	35
Fig. 12	HANDLE FRAME Mancherons	39
Fig. 13	CONTROL SYSTEM Commandes	43
Fig. 13A	CONTROL SYSTEM (W-type) Commandes	47
Fig. 14	BONNET and FUEL TANK Reservoir et capot	49
Fig. 15	BELT DRIVE Courroie intermediaire	51
Fig. 15A	BELT DRIVE (W-type) Courroie intermediaire	55
Fig. 16	WHEEL and WHEEL PIPE Roues	57

Fig. 17	PULLEY, SCRATCH FENDER, FRONT HITCH and PARKING BRAKE	61
	Poulie, garde-boue, attelage et frein	
Fig. 18	RECOIL STARTER	65
	Lanceur	
Fig. 19	TOOLS	67
	Outils	
Fig. 20	ROTARY BELT DRIVE	71
	Courroie intermediaire	
Fig. 21	REAR HITCH SYSTEM	73
	Mecanisme de securite	
Fig. 22	ROTARY CHAIN CASE	75
	Transmission de rotobineuse	
Fig. 23	ROTARY SHIFTER	77
	Embrayage de rotobineuse	
Fig. 24	ROTARY PIPE	79
	Fraise	
Fig. 25	ROTARY FRAME	81
	Enveloppe de rotobineuses	

Fig. 6 FRONT FRAME
Longeron

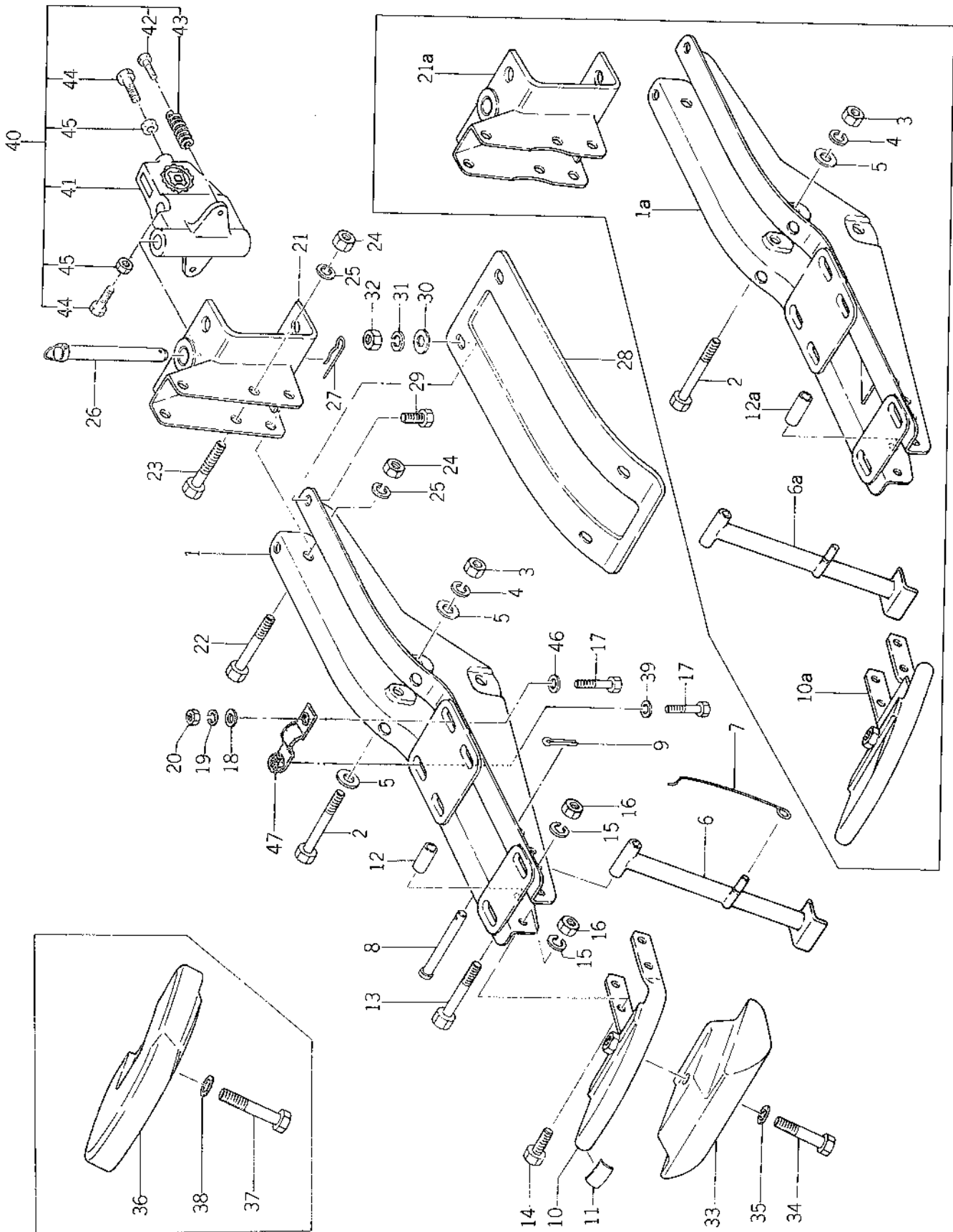

Ref No. Réf N°	Parts No. Pièces N°	Description Désignation	Model & Qty Modél & Quant		Remarks Remarques
			KC450	KC450F	
6- 1	1364-101-3000-1	FRAME, F Longeron	1	1	FNo. 100001-110740
6- 1a	1373-101-2000-0	FRAME Longeron		1	FNo. 110741- FENo. 500001-
6- 2	V20126-100550	BOLT/M10×55 Vis	2	2	
6- 3	V30026-001000	NUT/M10 Ecrou	2	2	
6- 4	V40126-001000	WASHER, SP/M10 Rondelle frein	2	2	
6- 5	V41316-001000	WASHER/M10 Rondelle	4	2	
6- 6	1364-106-1000-1	STAND Bequille	1	1	FNo. 100001-110740
6- 6a	1380-106-2000-0	STAND Bequille		1	FNo. 110741- FENo. 500001-
6- 7	1329-106-0010-0	SPRING, STAND Ressort	1	1	
6- 8	1329-106-0020-0	PIN, STAND Axe de bequille	1	1	FNo. 100001-110740
6- 8a	1353-106-0010-0	PIN, STAND Axe de bequille		1	FNo. 110741- FENo. 500001-
6- 9	V50015-250150	PIN, SPLIT/2.5×15 Goupille fendue	1	1	
6-10	1329-111-1000-0	BUMPER Pare-chocs	1	1	FNo. 100001-110740
6-10a	1373-111-2000-0	BUMPER Pare-chocs		1	FNo. 110741- FENo. 500001-
6-11	1329-111-0010-0	TAPE, BUMPER Bande	1	1	
6-12	1364-111-0010-0	PIPE/45 Collier	1	1	FNo. 100001-110740
6-12a	1373-111-0010-0	PIPE/52 Collier		1	FNo. 110741- FENo. 500001-
6-13	V20126-080700	BOLT/M8×70 Vis	1	1	FNo. 100001-110740
6-13a	V20126-080750	BOLT/M8×75 Vis		1	FNo. 110741- FENo. 500001-
6-14	V20126-080200	BOLT/M8×20 Vis	2	2	FNo. 100001-110740
6-14a	V20126-080160	BOLT/M8×16 Vis		2	FNo. 110741- FENo. 500001-
6-15	V40126-000800	WASHER, SP/M8 Rondelle frein	3	3	
6-16	V30026-000800	NUT/M8 Ecrou	3	3	
6-17	V20126-100400	BOLT/M10×40 Vis	4	4	
6-18	V41316-001000	WASHER/M10 Rondelle	3	3	
6-19	V40126-001000	WASHER, SP/M10 Rondelle frein	4	4	
6-20	V30026-001000	NUT/M10 Ecrou	3	3	
6-21	1364-930-1000-1	HITCH, R. Attelage	1	1	FNo. 100001-110740
6-21a	1364-930-1001-0	HITCH, R. Attelage		1	FNo. 110741- FENo. 500001-
6-21-1	1373-930-2000-0	HITCE, R. Attelage	1	1	
6-22	V20126-100650	BOLT/M10×65 Vis	1	1	
6-23	V20126-100600	BOLT/M10×60 Vis	2	2	
6-23a	V20126-100700	BOLT/M10×70 Vis		1	
6-24	V30026-001000	NUT/M10 Ecrou	3	3	
6-24a	V30026-001000	NUT/M10 Ecrou		2	
6-25	V40116-001000	WASHER, SP/M10 Rondelle frein	3	3	
6-25a	V40116-001000	WASHER, SP/M10 Rondelle frein		2	
6-26	1301-100-9010-0	PIN, KING ASSY Broche	1	1	

Fig. 6 FRONT FRAME
Longeron

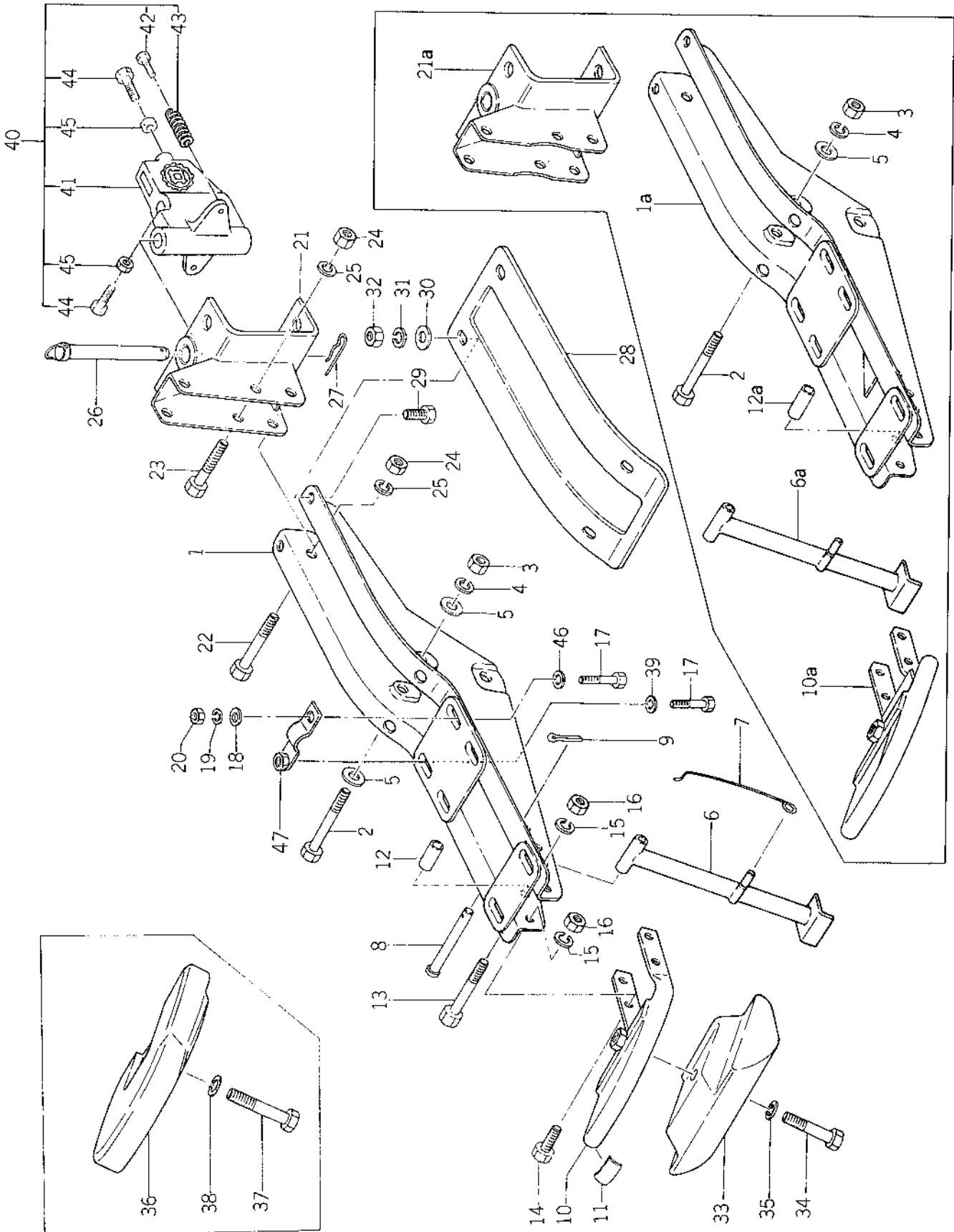

Ref No. Réf N°.	Parts No. Pièces N°.	Description Désignation	Model & Q'ty Modél & Quant		Remarks Remarques
			KC450	KC450P	
6-27	1305-931-0030-0	PIN, HAIR Attache beta	1	1	
6-28	1364-616-0010-1	FENDER Garde-boue	2	2	
6-29	V20126-080160	BOLT/M8×16 Vis	4	4	
6-30	V41326-000800	WASHER/M8 Rondelle	4	4	
6-31	V40126-000800	WASHER, SP/M8 Rondelle frein	4	4	
6-32	V30026-000800	NUT/M8 Ecrou	4	4	
6-33	1329-931-0010-1	WEIGHT, BALANCE/5 Contrepois	1	1	
6-34	V20126-100650	BOLT/M10×65 Vis	1	1	
6-35	V40126-001000	WASHER, SP/M10 Rondelle frein	1	1	
6-36	1329-931-0030-1	WEIGHT, BALANCE B Contrepois	1	1	
6-37	V20126-100560	BOLT/M10×56 Vis	1	1	
6-38	V40126-001000	WASHER, SP/M10 Rondelle frein	1	1	
6-39	1365-121-0050-0	WASHER/10×20×2 Rondelle	4	2	
6-40	8057-006-0000-0	HITCH, CULTI ASSY Attache culti ensemble	1	1	★
6-41		·HITCH, CULTI Attache culti	1	1	△
6-42	8057-006-0020-0	·BOLT Vis	2	2	★
6-43	8057-006-0030-0	·SPRING Ressort	2	2	★
6-44	V20126-120400	·BOLT/M12×40 Vis	2	2	★
6-45	V30226-001200	·NUT/M12 Ecrou	2	2	★
6-46	1375-121-0010-0	WASHER Rondelle	2	2	
6-47	1374-121-2200-0	PLATE, SET Plaque	1	1	

Fig. 7 TRANSMISSION GEAR CASE (For KC350)
Boitier de reducteur

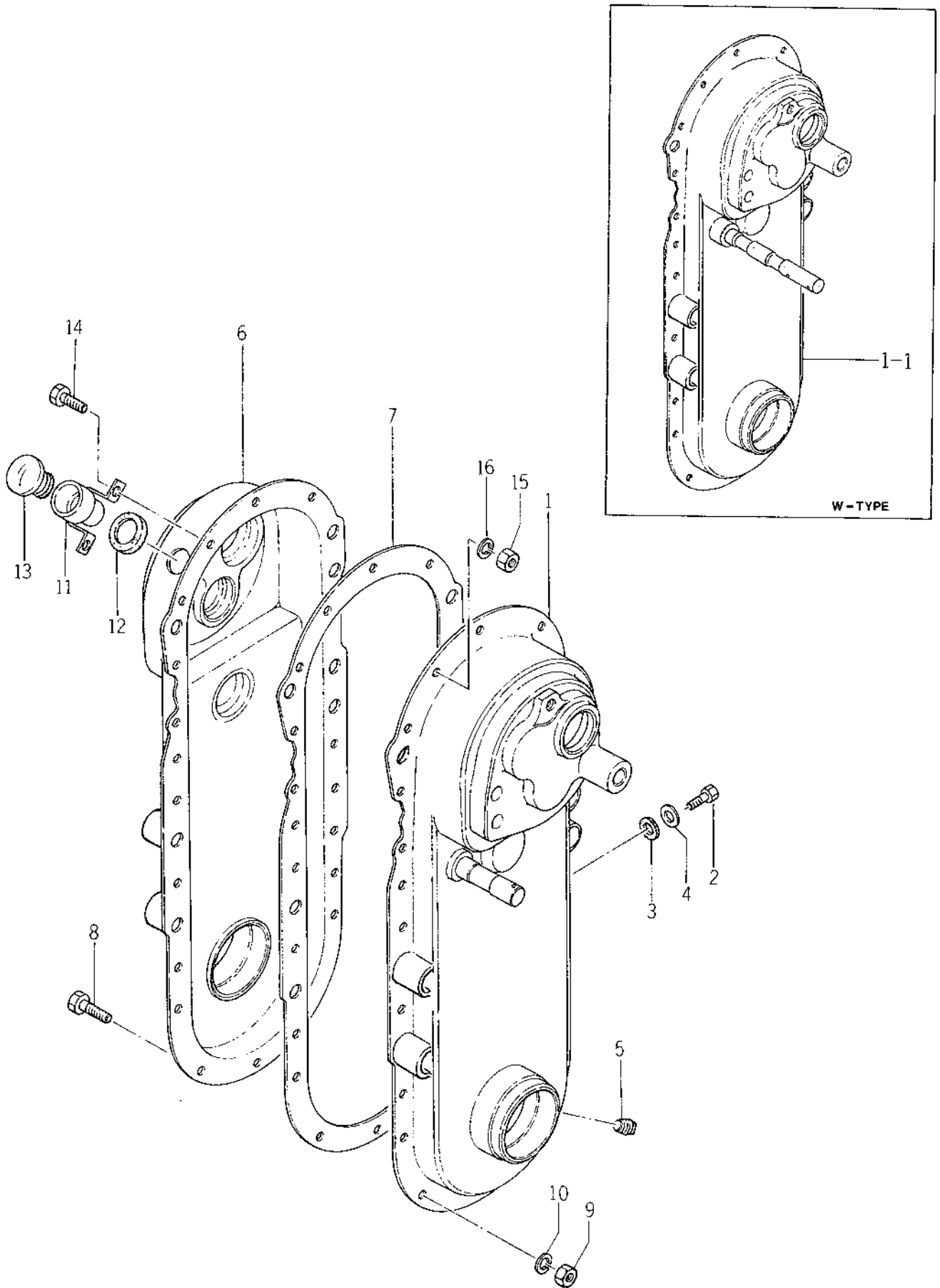

Ref No. Réf N°.	Parts No. Pièces N°.	Description Désignation	Model & Q'ty Modél & Quant		Remarks Remarques
			KC450	KC450F	
7- 1	1364-216-1001-1	CASE, MAIN GEAR LH Coquille G.	1		
7- 1-1	1364-266-2000-0	CASE, MAIN GEAR LH Coquille G.	1		for W-type
7- 2	V20026-060100	BOLT/M6×10 Vis	1		
7- 3	1324-212-0040-0	PAKING, OIL LEVEL Joint	1		
7- 4	V41116-000600	WASHER/M6 Rondelle	1		
7- 5	7955-201-0260-0	PLUG, DRAIN Bouchon	1		
7- 6	1364-216-2001-1	CASE, MAIN GEAR RH Coquille D.	1		
7- 7	1364-216-0010-0	PACKING, MAIN GEAR CASE Joint	1		
7- 8	V20020-060120	BOLT/M6×12 Vis	22		
7- 9	V30020-000600	NUT/M6 Erou	22		
7-10	V40120-000600	WASHER, SP/M6 Rondelle frein	22		
7-11	1364-216-3000-1	PIPE, OIL Tubulure	1		
7-12	1364-216-0020-0	PACKING/RUBBER Joint	1		
7-13	1366-706-0010-0	CAP, OIL/23 Bouchon	1		
7-14	V20020-060160	BOLT/M6×16 Vis	2		
7-15	V30020-000600	NUT/M6 Erou	2		
7-16	V40120-000600	WASHER, SP/M6 Rondelle frein	2		

Fig. 8

TRANSMISSION GEAR CASE (For KC450F)

Boitier de reducteur

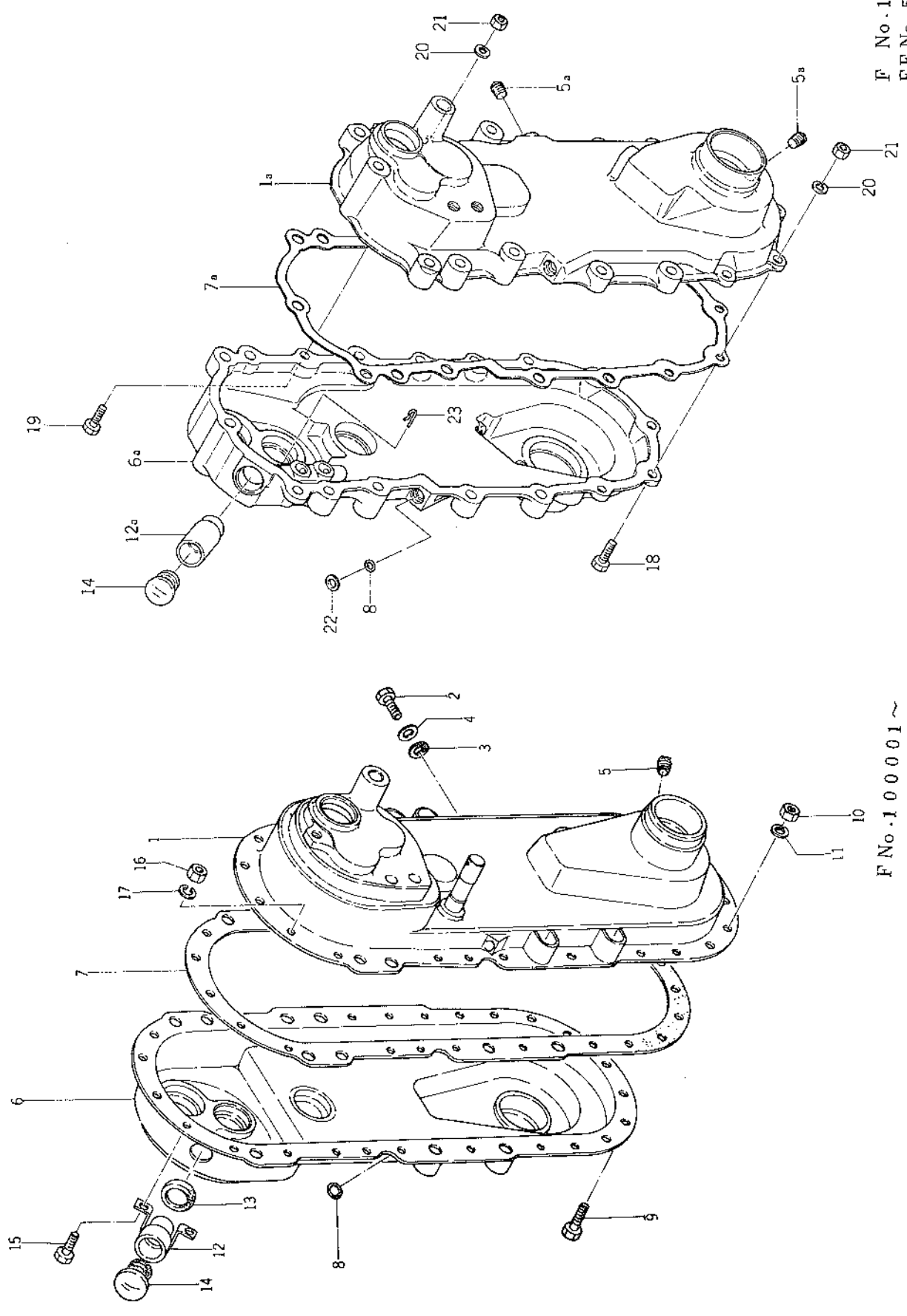

F No.110741~
FENo.500001~

FNo.100001~
110740

Ref No. Réf N°.	Parts No. Pièces N°.	Description Désignation	Model & Q'ty Modél & Quant		Remarks Remarques
			KC450	KC450F	
8- 1	1373-216-1000-1	CASE, MAIN GEAR LH Coquille G.		1	FNo. 100001-110740
8- 1a	1373-215-0010-0	CASE, MAIN GEAR LH Coquille G.		1	FNo. 110741- FENo. 500001-
8- 2	V20026-060100	BOLT/M6×10 Vis		1	
8- 3	1324-212-0040-0	PACKING, OIL LEVEL Joint		1	
8- 4	V41116-000600	WASHER/M6 Rondelle		1	
8- 5	7955-201-0260-0	PLUG, DRAIN Bouchon		1	FNo. 100001-110740
8- 5a	7955-201-0260-0	PLUG, DRAIN Bouchon		2	FNo. 110741- FENo. 500001-
8- 6	1373-216-2000-1	CASE, MAIN GEAR RH Coquille D.		1	FNo. 100001-110740
8- 6a	1373-215-0020-0	CASE, MAIN GEAR RH Coquille D.		1	FNo. 110741- FENo. 500001-
8- 7	1373-216-0010-0	PACKING, MAIN GEAR CASE Joint		1	FNo. 100001-110740
8- 7a	1373-215-0030-0	PACKING, MAIN GEAR CASE Joint		1	FNo. 110741- FENo. 500001-
8- 8	1373-216-0020-0	O-RING/NOKA305 Joint torique		2	
8- 9	V20020-060120	BOLT/M6×12 Vis		21	
8-10	V30020-000600	NUT/M6 Ecrou		21	
8-11	V40120-000600	WASHER, SP/M6 Rondelle frein		21	
8-12	1364-216-3000-1	PIPE, OIL Tubulure		1	FNo. 100001-110740
8-12a	1373-215-0040-0	PIPE, OIL Tubulure		1	FNo. 110741- FENo. 500001-
8-13	1364-216-0020-0	PACKING/RUBBER Joint		1	FNo. 100001-110740
8-14	1366-706-0010-0	CAP, OIL/23 Bouchon		1	
8-15	V20020-060160	BOLT/M6×16 Vis		2	} FNo. 100001-110740
8-16	V30020-000600	NUT/M6 Ecrou		2	
8-17	V40120-000600	WASHER, SP/M6 Rondelle frein		2	
8-18	V20126-080300	BOLT/M8×30 Vis		7	} FNo. 110741- FENo. 500001-
8-19	V20126-080250	BOLT/M8×25 Vis		1	
8-20	V40116-000800	WASHER, SP/M8 Rondelle frein		8	
8-21	V30026-000800	NUT/M8 Ecrou		8	
8-22	1373-215-0060-0	BUSH Cousinet		2	
8-23	1373-215-0050-0	PIN, HAIR Attache beta		1	

Fig. 9 TRANSMISSION GEAR
Reducteur

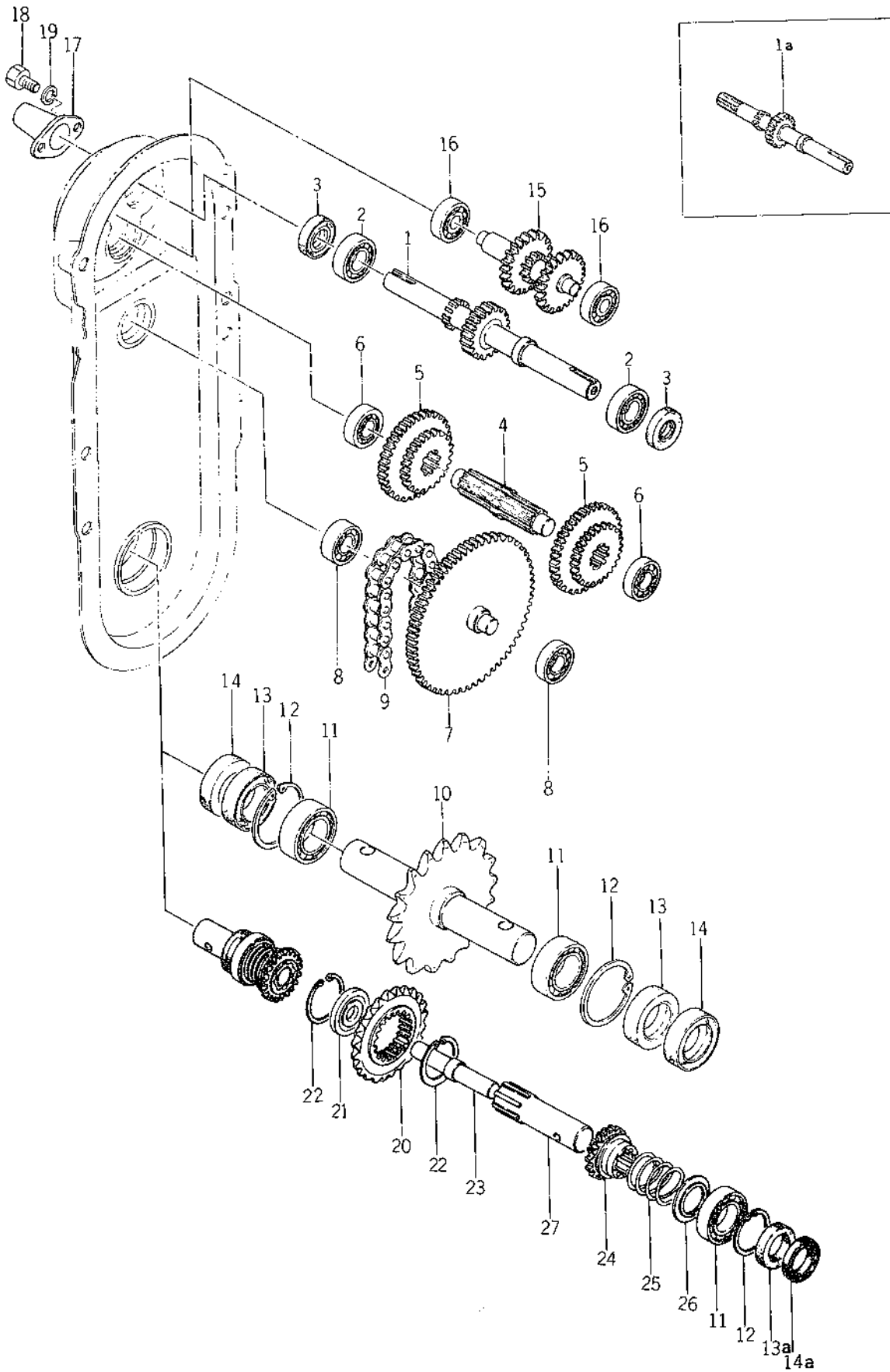

Ref No. Réf N°.	Parts No. Pièces N°.	Description Désignation	Model & Q'ty Modél & Quant		Remarks Remarques
			KC450	KC450F	
9- 1	1364-217-1000-0	SHAFT, MAIN/22T Arbre primaire	1	1	
9- 1a	1364-214-2000-0	SHAFT, MAIN/22T Arbre primaire	1	1	spline-type
9- 2	V60011-062030	BEARING, RB/6203 Roulement	2	2	
9- 3	V74011-735070	SEAL, OIL/SC17357 Bague d'étanchéité	2	2	
9- 4	1364-218-0010-0	SHAFT, CHANGE Arbre secondaire	1	1	
9- 5	1364-218-0020-0	GEAR, SHIFT/25-37T Baladeur	2	2	
9- 6	V60011-062020	BEARING, RB/6202 Roulement	2	2	
9- 7	1364-219-1001-1	SHAFT, COUNTER Arbre intermédiaire	1	1	
9- 8	V60011-063020	BEARING, RB/6302 Roulement	2	2	
9- 9	1364-219-0010-0	CHAIN, ROLLER Chaîne	1	1	
9-10	1364-225-1000-0	SHAFT, WHEEL Fusse	1		
9-11	V60011-060060	BEARING, RB/6006 Roulement	2	2	
9-12	V70510-005500	RING, SNAP/C 55 Collet d'axe	2	2	
9-13	V74413-055120	SEAL, OIL/TC305512 Bague d'étanchéité	2	2	FNo. 100001-110740
9-13a	V74413-050110	SEAL, OIL/TC305011 Bague d'étanchéité		2	FNo. 110741- FENo. 500001-
9-14	V74213-055050	SEAL, OIL/VC30555 Bague d'étanchéité	2	2	FNo. 100001-110740
9-14a	V74213-050080	SEAL, OIL/VC30508 Bague d'étanchéité		2	FNo. 110741- FENo. 500001-
9-15	1364-226-1000-0	SHAFT, BACK/22T Arbre	1	1	
9-16	V60011-062010	BEARING, RB/6201 Roulement	2	2	
9-17	1364-216-0030-1	CAP, SHAFT/24 x 50 Chapeau d'arbre	1	1	
9-18	V20026-060100	BOLT/M6 x 10 Vis	2	2	
9-19	V40126-000600	WASHER, SP/M6 Rondelle frein	2	2	
9-20	1373-225-0030-0	SPROCKET, DRIVE/22T Pignon		1	
9-21	1373-225-0010-0	COLLAR, WHEEL SHAFT Arbre de roues		1	
9-22	V70510-007800	RING, SNAP/C 78 Collet d'axe		2	
9-23	1337-225-0070-0	PIN, WHEEL SHAFT Arbre		1	
9-24	1373-225-0050-0	GEAR, SIDE CLUTCH/26T Ciabot		2	
9-25	1351-225-0010-0	SPRING, SIDE CLUTCH Ressort		2	
9-26	1373-225-0040-0	PLATE Support		2	
9-27	1373-225-0020-0	SHAFT, WHEEL Fusse		2	

Fig. 10 SHIFTER
Fourchettes

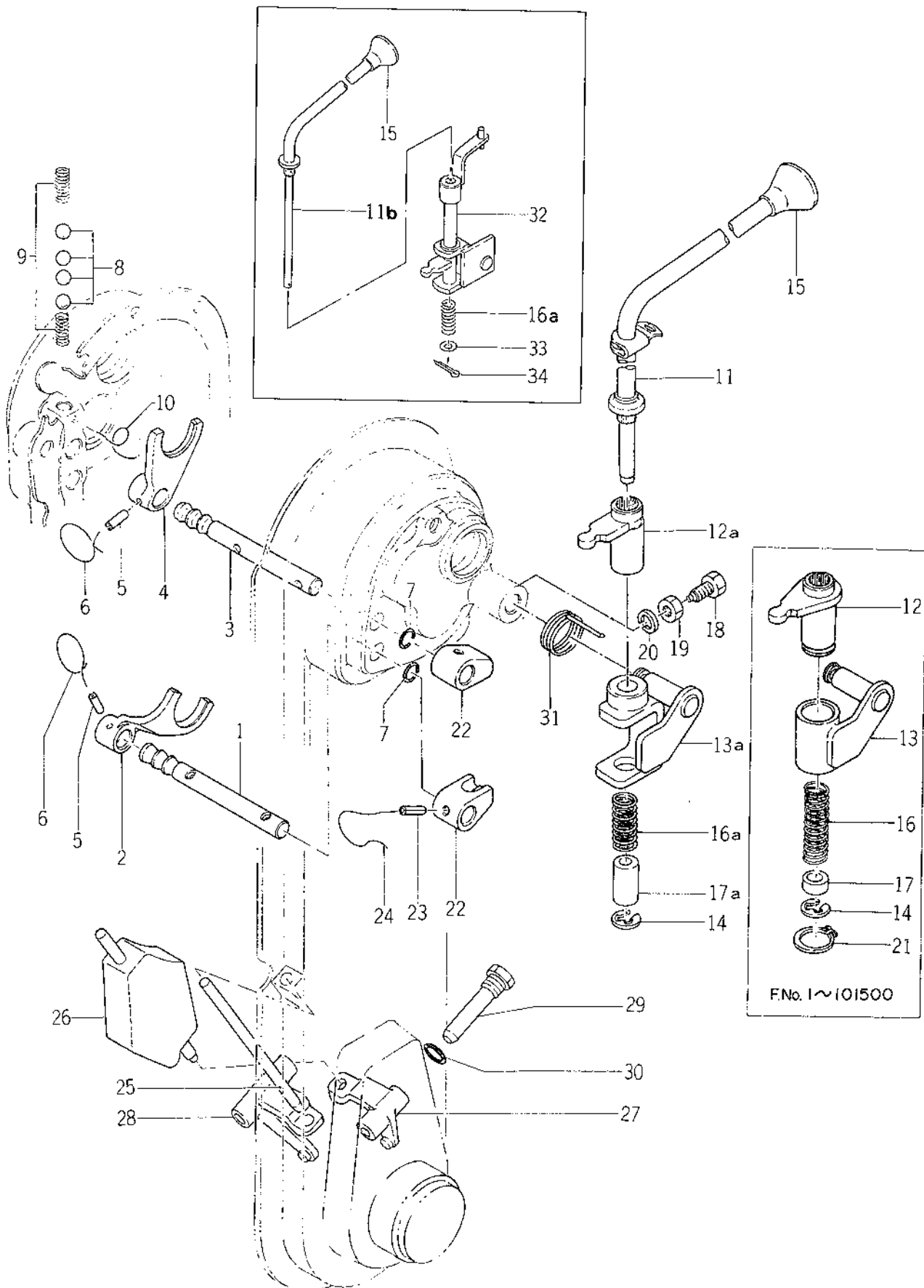

Ref No. Réf N°	Parts No. Pièces N°	Description Désignation	Model & Q'ty Modél & Quant		Remarks Remarques
			KC450	KC450F	
10- 1	1364-229-0010-0	STAY, MAIN SHIFTER Axe de fourchette	1	1	
10- 2	1364-229-0020-0	SHIFTER, MAIN Fourchette	1	1	
10- 3	1364-229-0030-0	STAY, BACK SHIFTER Axe de fourchette	1	1	
10- 4	1364-229-0040-0	SHIFTER, BACK Fourchette	1	1	
10- 5	V58110-040220	PIN, SPRING/4×22 Goupille elastique	2	2	
10- 6		WIRE/1.2×150 Fil	2	2	
10- 7	V72010-240120	O-RING/P12 Joint torique	2	2	
10- 8	V68010-000100	BALL, STEEL 5/16 Bille	4	4	
10- 9	1302-225-0030-0	SPRING, SHIFTER Ressort	2	2	
10-10		WIRE/1.6×3.5 Fil	1	1	
10-11	1364-403-1000-0	LEVER, SHIFT Lever		1	FNo. 1-101500
10-11a	1364-403-4000-0	LEVER SHIFT Lever	1	1	FNo. 101501-
10-11b	1364-413-2000-0	LEVER, SHIFT Lever	1	1	
10-12	1364-403-2000-0	ARM, SHIFT . Selecteur		1	FNo. 1-101500
10-12a	1364-403-5000-0	ARM, SHIFT Selecteur	1	1	FNo. 101501-
10-13	1364-403-3000-0	SUPPORT, LEVER Support		1	FNo. 1-101500
10-13a	1364-403-6000-0	SUPPORT, LEVER Support	1	1	FNo. 101501-
10-14	V71029-000700	RING, SNAP/E 7 Collet d'axe	1	1	
10-15	3555-102-0140-0	GRIP, SHIFT LEVER Poignée	1	1	
10-16	1364-401-0010-0	SPRING, PRESS/57 Ressort		1	FNo. 1-101500
10-16a	1364-403-0050-0	SPRING, PRESS/39 Ressort	1	1	FNo. 101501-
10-17	1364-403-0020-0	COLLAR/10×16×8 Collier		1	FNo. 1-101500
10-17a	1364-403-0060-0	COLLAR/10×16×29 Collier	1	1	FNo. 101501-
10-18	1364-403-0030-0	BOLT, SET/8×25 Vis	1	1	
10-19	V30226-000800	NUT/M8 Ecrou	1	1	
10-20	V40126-000800	WASHER, SP/M8 Rondelle frein	1	1	
10-21	V70410-002100	RING, SNAP/C 21 Collet d'axe	1	1	FNo. 1-101500
10-22	1364-403-0040-0	BOSS, CHANGE Collier	2	2	
10-23	V58014-040220	PIN, SPRING/4×22 Goupille elastique	2	2	
10-24	V59013-121500	WIRE/1.2×150 Fil	2	2	
10-25	1373-230-0010-0	ROD, LH Doigt G.		1	
10-26	1373-230-1000-0	ROD, RH Doigt D.		1	
10-27	1373-230-0020-0	SHIFTER, SIDE CLUTCH Fourchette de clabotage		1	
10-28	1373-230-0030-0	SHIFTER, SIDE CLUTCH Fourchette de clabotage		1	
10-29	1373-230-0040-0	PIN, SIDE CLUTCH Pivot		2	FNo. 100001-110740
10-29a	1373-231-0010-0	PIN, SIDE CLUTCH Pivot		2	FNo. 110741- FENo. 500001-
10-30	V72010-240100	O-RING/P10A Joint torique		2	FNo. 100001-110740
10-30a	V72010-240120	O-RING/P12 Joint torique		2	FNo. 110741- FENo. 500001-

Fig. 10 SHIFTER
Fourchettes

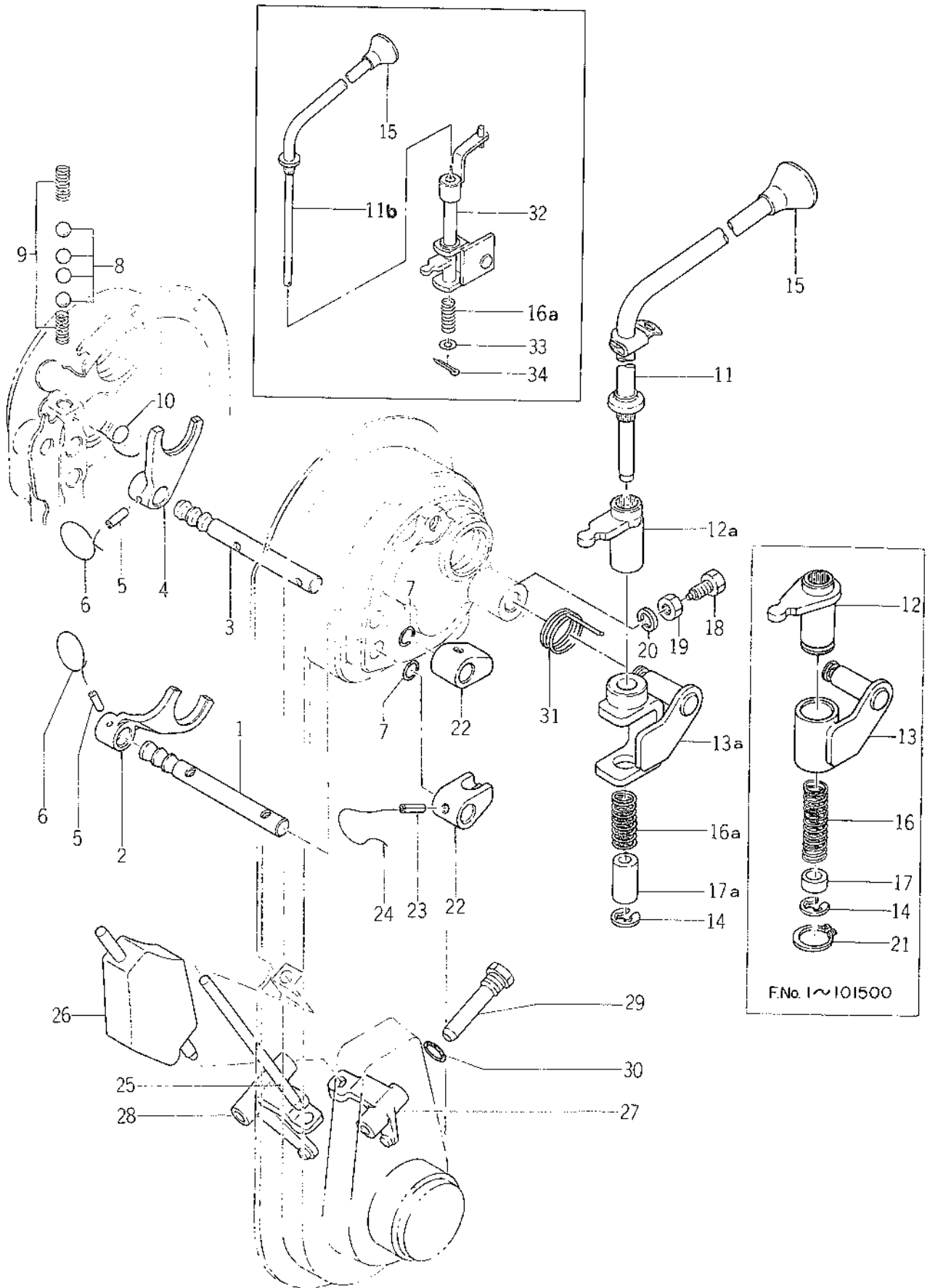

Ref No. Réf N°.	Parts No. Pièces N°.	Description Désignation	Model & Q'ty Modél & Quant		Remarks Remarques
			KC450	KC450F	
10-31	1364-403-0081-0	SPRING, TORQUE/36 Ressort	1	1	No. 771- FNo. 106491-
10-32	1364-413-2100-0	LEVER, SELECT Lever	1	1	
10-33	V41316-000800	WASHER/M8 Rondelle	1	1	
10-34	V50015-200160	PIN, SPLIT/2×15 Goupille elastique	1	1	

Fig. 11 HANDLE FRAME
Mancherons

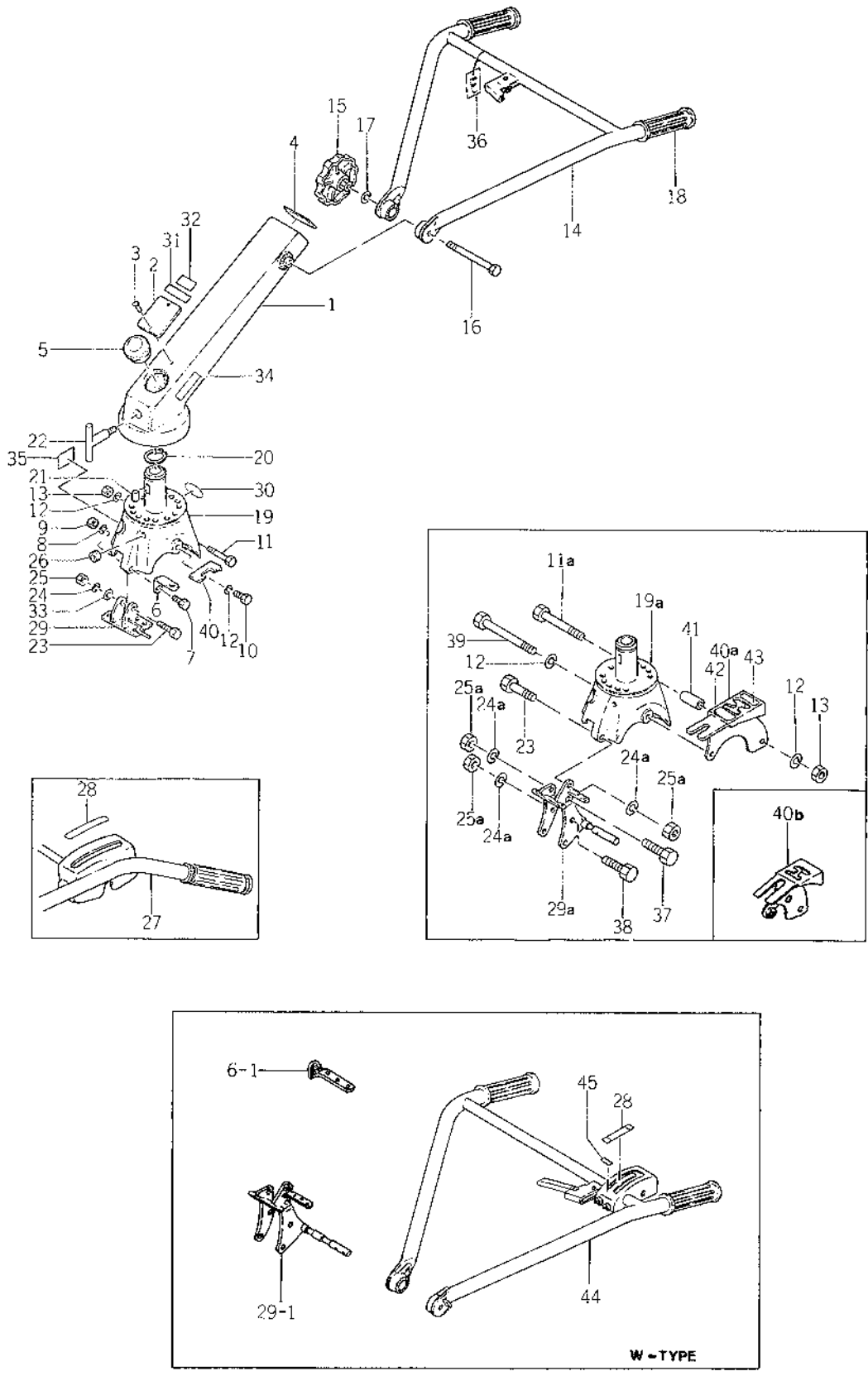

Ref No. Réf N°.	Parts No. Pièces N°.	Description Désignation	Model & Q'ty Modél & Quant		Remarks Remarques
			KC450	KC450F	
11- 1	1364-301-1004-0	FRAME, HANDLE Age	1	1	
11- 2	1374-951-0011-0	MARK, MODEL A Plaquette	1		
11- 2-1	1375-951-0010-0	MARK, MODEL A Plaquette		1	
11- 3	V291-202-0005-0	RIVET /2x5 Rivet	2	2	
11- 4	1364-952-0020-0	MARK, SHIFT Repere de vitesses	1	1	
11- 5	1364-301-0030-0	CAP, HANDLE Bouchon	1	1	
11- 6	1364-401-1000-0	SUPPORT, WIRE Support	1		no use for W-type
11- 6-1	1364-451-2000-0	SUPPORT, WIRE Support	1		for W-type
11- 7	V201-261-0045-0	BOLT/M10x45 Vis	1		
11- 8	V401-260-0100-0	WASHER, SP/M10 Rondelle frein	1		
11- 9	V300-260-0100-0	NUT/M10 Ecrou	1		
11-10	V201-261-0016-0	BOLT/M10x16 Vis	2		
11-11	V201-261-0060-0	BOLT/M10x60 Vis	1	1	
11-11a	V201-261-0100-0	BOLT/M10x100 Vis	1	1	
11-12	V401-160-0100-0	WASHER, SP/M10 Rondelle frein	2	2	
11-13	V300-260-0100-0	NUT/M10 Ecrou	2	2	
11-14	1364-311-1002-1	HANDLE Mancheron delta	1		no use for W-type
11-15	1354-311-2000-0	KNOB, SET Fermeture	1	1	
11-16	V200-461-0140-0	BOLT/M10x140 8T Vis	1	1	
11-17	V401-260-0100-0	WASHER, SP/M10 Rondelle frein	1	1	
11-18	2100-401-0010-0	GRIP, HANDLE Poignée	2	2	
11-19	1364-301-2001-1	BRACKET, HANDLE Support	1	1	FNo. 100001-110740
11-19a	1373-301-2000-0	BRACKET, HANDLE Support		1	FNo. 110741- FENo. 500001-
11-20	V704-190-0550-0	RING, SNAP/C 55 Collet d'axe	1	1	
11-21	1364-301-0040-0	METAL, LOCK Coquille	1	1	
11-22	1364-301-3000-0	BOLT, SET Vis	1	1	
11-23	V201-261-0050-0	BOLT/M10x50 Vis		1	
11-23-1	V201-260-0045-0	BOLT/M10x45 Vis		1	for W-type
11-24	V401-160-0100-0	WASHER, SP/M10 Rondelle frein		1	FNo. 100001-110740
11-24a	V401-160-0100-0	WASHER, SP/M10 Rondelle frein		3	FNo. 110741- FENo. 500001-
11-25	V300-260-0100-0	NUT/M10 Ecrou		1	FNo. 100001-110740
11-25a	V300-260-0100-0	NUT/M10 Ecrou		3	FNo. 110741- FENo. 500001- 2 used for W-type
11-26	1364-301-0050-0	GROMMET/16x20 Oeillet	1	1	
11-27	1373-311-1000-0	HANDLE Mancheron delta		1	no use for W-type
11-28	1351-952-0020-0	MARK, CLUTCH Etiquette		1	1 used for KC450-W
11-29	1373-401-2000-1	SUPPORT, WIRE Support		1	FNo. 100001-110740
11-29a	1373-401-2100-0	SUPPORT, WIRE Support		1	FNo. 110741- FENo. 500001- no use for W-type
11-29-1	1373-451-2000-0	SUPPORT, WIRE Support		1	for W-type

Fig. 11 HANDLE FRAME
Mancherons

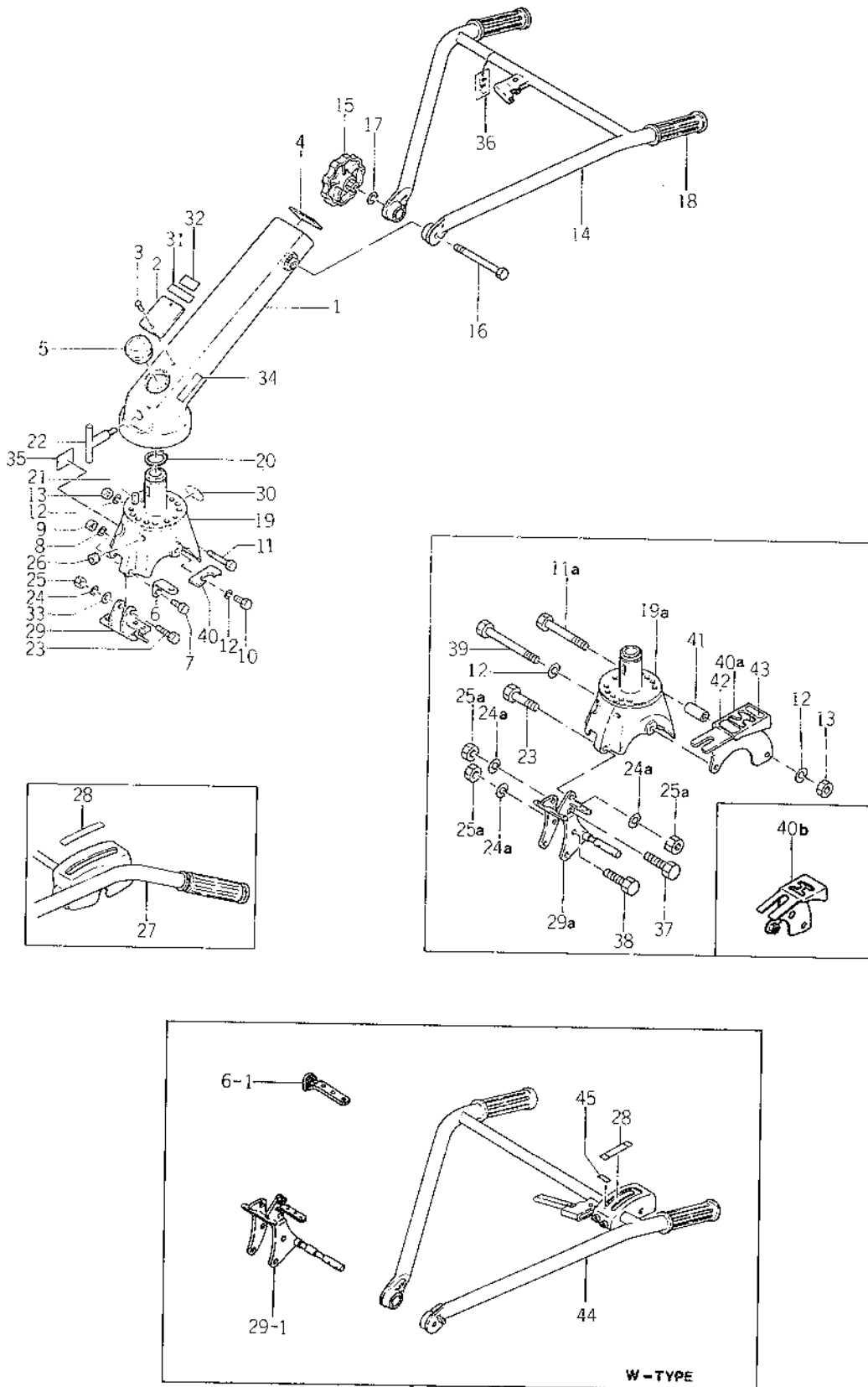

Ref No. Réf N°.	Parts No. Pièces N°.	Description Désignation	Model & Q'ty Modél & Quant		Remarks Remarques
			KC450	KC450F	
11-30	4114-606-0030-0	MARK, ISO Etiquette	1	1	Abolished
11-31	1324-957-0120-0	MARK, DESTINATION Etiquette	1	1	
11-32	1331-954-0060-0	MARK Etiquette	1	1	
11-33	V413-160-0100-0	WASHER/M10 Rondelle	1	2	FNo. 110741- FENo. 500001-
11-34	1368-953-0010-0	MARK, CAUTION A Etiquette	1	1	
11-35	1368-953-0020-0	MARK, CAUTION B Etiquette	1	1	
11-36	1364-902-0090-0	TAG, OIL CAUTION Etiquette	1	1	
11-37	V201-261-0070-0	BOLT/M10×70 Vis		1	
11-38	V201-261-0085-0	BOLT/M10×85 Vis		1	FNo. 110741- FENo. 500001-
11-39	V201-261-0135-0	BOLT/M10×135 Vis		1	
11-40	1364-403-0070-0	GUIDE, SHIFT LEVER Grille de vitesses		1	No. 771- FNo. 106491-
11-40a	1380-612-2120-0	GUIDE, SHIFT LEVER Grille de vitesses	1		
11-40b	1373-613-2000-0	GUIDE, SHIFT LEVER Grille de vitesses		1	
11-41	1380-612-0010-0	PIPE/38 Conduit	1	1	
11-42	1364-952-0030-0	MARK SHIFT A Repere de vitesses	1	1	
11-43	1364-952-0040-0	MARK, SHIFT B Repere de vitesses	1	1	
11-44	1380-311-2000-1	HANDLE Mancheron delta	1	1	} for W-type
11-45	1352-952-0010-0	MARK, CLUTCH A Etiquette	1	1	

Fig. 12

CONTROL SYSTEM
Commandes

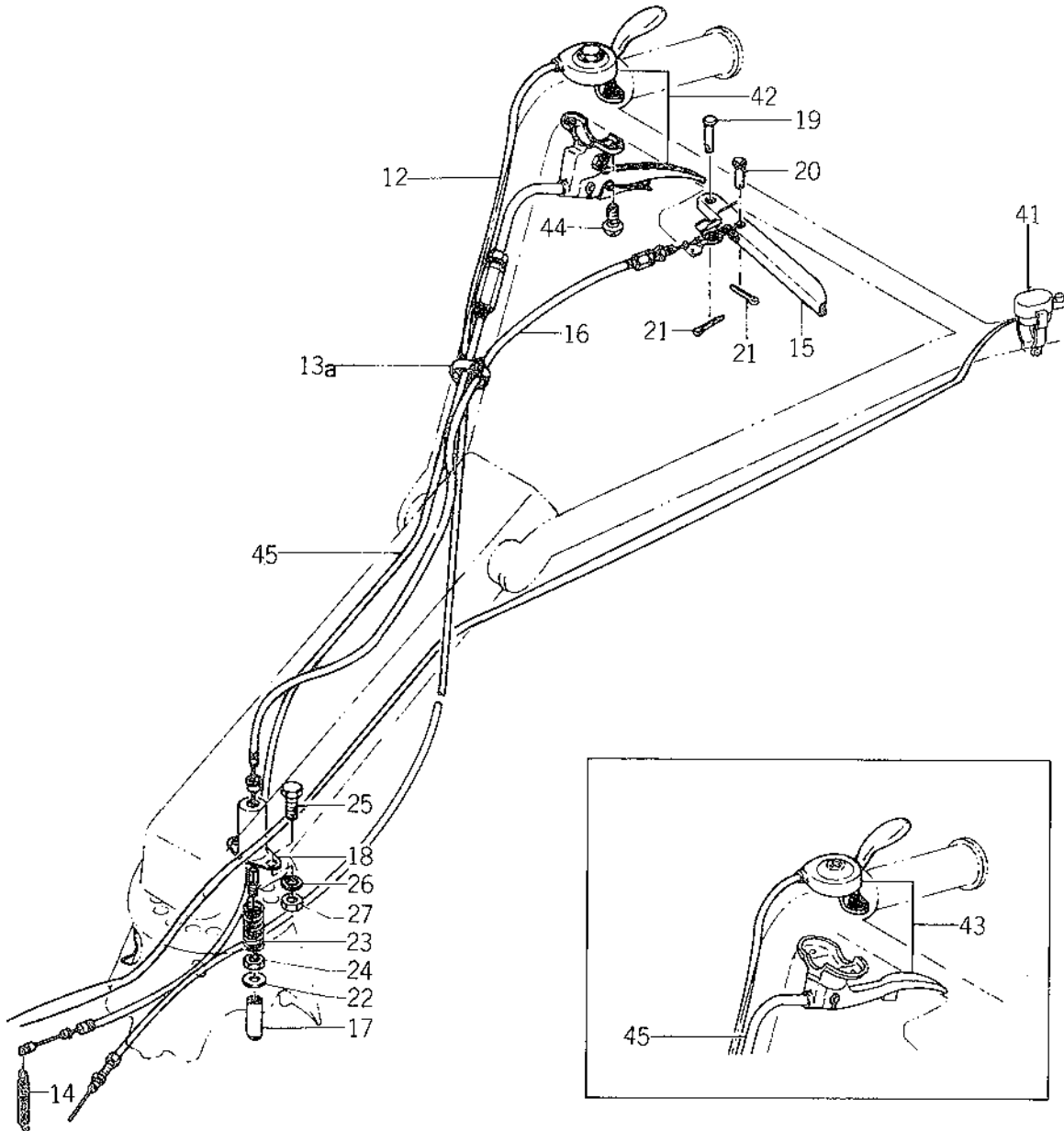
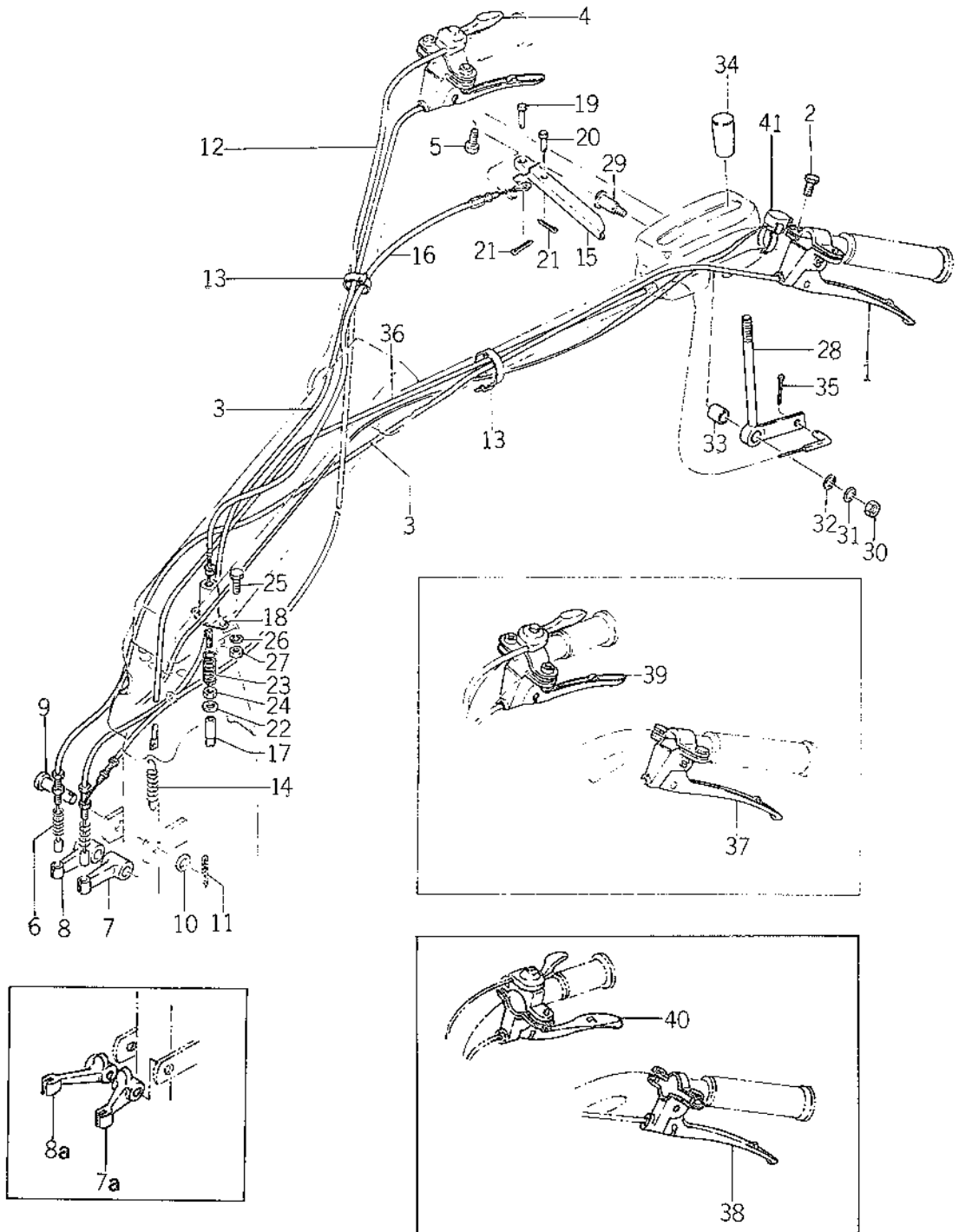

Fig. 12

CONTROL SYSTEM
Commandes



No. 12

Ref No. Réf No.	Parts No. Pièces No.	Description Désignation	Model & Q'ty Modél & Quant		Remarks Remarques
			KC450	KC450F	
12- 1	1351-400-0510-0	LEVER, SIDE CLUTCH ASSY Poignée, G.		1	} FNo. 1-101700
12- 2	V20025-060300	BOLT/M6 × 30 Vis		2	
12- 3	1373-406-0010-0	WIRE, SIDE CLUTCH Cable de clabotage		2	
12- 4	1351-400-0520-0	LEVER, THROTTLE ASSY Manette des gaz		1	} FNo. 1-101700
12- 5	V20025-060250	BOLT/M6 × 25 Vis		1	
12- 6	1373-406-0020-0	SPRING, PRESS/100 Ressort		2	
12- 7	1373-406-0030-0	ARM, SIDE CLUTCH LH Etrier, G.		1	FNo. 100001-109390 FNo. 500001-501100
12- 7a	1373-406-0031-0	ARM, SIDE CLUTCH LH Etrier, G.		1	FNo. 109391- FNo. 501101-
12- 8	1373-406-0040-0	ARM, SIDE CLUTCH RH Etrier, D.		1	FNo. 100001-109390 FNo. 500001-501100
12- 8a	1373-406-0041-0	ARM, SIDE CLUTCH RH Etrier, D.		1	FNo. 109391- FNo. 501101-
12- 9	1373-406-0050-0	PIN, SIDE CLUTCH ARM Goupille		1	
12-10	V41316-001200	WASHER/M12 Rondelle		1	
12-11	V50015-300220	PIN, SPLIT/3 × 22 Goupille fendue		1	
12-12	1365-402-0010-0	WIRE, THROTTLE Cable d'accélérateur	1	1	
12-13	1315-621-0140-0	BAND, WIRE RETAINER Sangle	1	2	FNo. 100001-110740
12-13a	1376-402-0030-0	BAND, WIRE/140 Sangle		2	FNo. 110741- FNo. 500001-
12-14	1374-401-0010-0	SPRING, CLUTCH Ressort	1	1	
12-15	1364-404-0010-0	LEVER, LOCK Lever	1	1	
12-16	1364-404-0020-0	WIRE, LOCK Cable	1	1	
12-17	1364-404-0031-0	PIN, LOCK Axe	1	1	
12-18	1364-404-0040-1	CASE, SPRING Carter de ressort	1	1	
12-19	1364-404-0050-0	PIN/6 × 19 Goupille	1	1	
12-20	1326-401-0070-0	PIN, MAIN CLUTCH CAM Goupille	1	1	
12-21	V50016-200140	PIN, SPLIT/2 × 14 Goupille fendue	2	2	
12-22	3740-162-0050-0	WASHER/6.5 × 18 × 1 Rondelle	2	2	
12-23	1364-404-0060-0	SPRING, PRESS/59 Ressort	1	1	
12-24	V30226-000600	NUT/M6 Erou	1	1	
12-25	V20026-060120	BOLT/M6 × 12 Vis	2	2	
12-26	V40126-000600	WASHER, SP/M6 Rondelle frein	2	2	
12-27	V30026-000600	NUT/M6 Erou	2	2	
12-28	1373-401-1000-0	LEVER, MAIN CLUTCH Lever d'embrayage		1	
12-29	1351-401-0020-0	PIN, CLUTCH LEVER Axe d'embrayage		1	
12-30	V30026-900800	NUT/M8 Erou		1	
12-31	V40116-000800	WASHER, SP/M8 Rondelle frein		1	
12-32	V41316-000600	WASHER/M6 Rondelle		1	
12-33	1351-401-0030-0	COLLAR/13 × 17 × 16 Collier		1	
12-34	4106-105-3030-0	KNOB Poignée		1	
12-35	V50015-200150	PIN, SPLIT/2 × 15 Goupille fendue		1	

Ref No. Réf N°.	Parts No. Pièces N°.	Description Désignation	Model & Q'ty Modél & Quant		Remarks Remarques
			KC450	KC450F	
12-36	1373-401-0010-0	WIRE, MAIN CLUTCH Cable		1	
12-37	1373-406-2000-0	LEVER, SIDE CLUTCH LH Poignée G.		1	} FNo. 101701-
12-38	1373-406-2200-0	LEVER, SIDE CLUTCH LH Poignée G.		1	
12-39	1373-406-2100-0	LEVER, SIDE CLUTCH RH Poignée D.		1	
12-40	1373-406-2300-0	LEVER, SIDE CLUTCH RH Poignée D.		1	
12-41	1375-621-2000-0	SWITCH, STOP ASSY Interrupteur	1	1	FENo. 500001-
12-42	1364-400-0510-0	LEVER, MAIN CLUTCH ASSY Lever d'embrayage	1		
12-43	1364-401-2000-0	LEVER, MAIN CLUTCH ASSY Lever d'embrayage	1		
12-44	V11116-600230	· SCREW/M6 x 23 Vis	1		
12-45	1364-401-0020-0	WIRE, MAIN CLUTCH Cable d'embrayage	1		

Fig. 12 A CONTROL SYSTEM (W-type)
Commandes

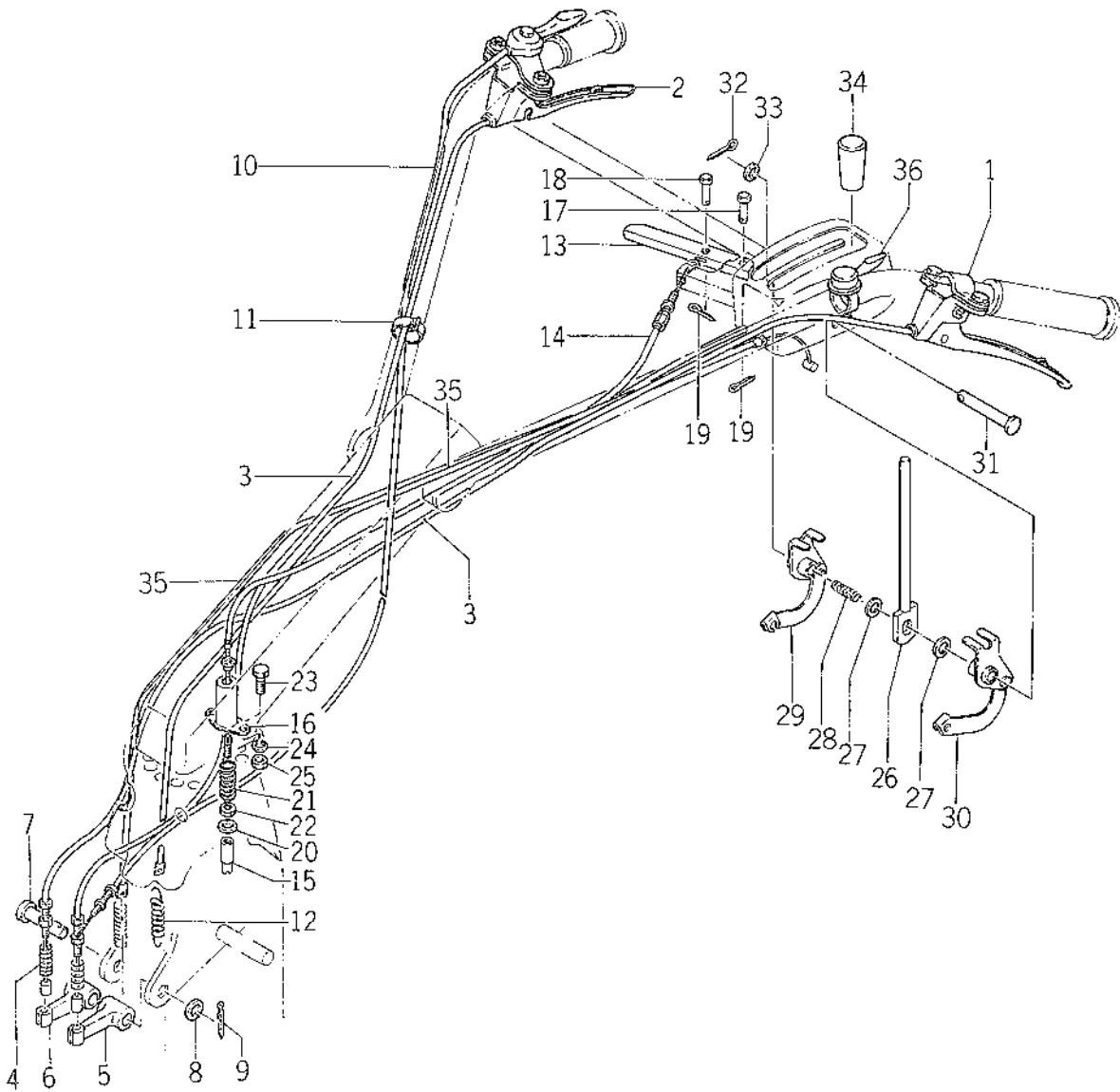

Ref No. Réf N°.	Parts No. Pièces N°.	Description Désignation	Model & Q'ty Modél & Quant		Remarks Remarques
			KC450	KC450F	
12A- 1	1373-406-2000-0	LEVER, CLUTCH LH Poignée G.		1	interchangeable
12A- 2	1373-406-2100-0	LEVER, CLUTCH RH Poignée D.		1	
12A- 1-1	1373-406-2200-0	LEVER, CLUTCH RH Poignée G.		1	
12A- 2-1	1373-406-2300-0	LEVER, CLUTCH RH Poignée D.		1	
12A- 3	1373-406-0010-0	WIRE, SIDE CLUTGE Cable de clabotage		2	
12A- 4	1373-406-0020-0	SPRING, PRESS/100 Ressort		2	
12A- 5	1373-406-0031-0	ARM, SIDE CLUTCH LH Etrier G.		1	
12A- 6	1373-406-0041-0	ARM, SIDE CLUTCH RH Etrier D.		1	
12A- 7	1373-406-0050-0	PIN, CLUTCH ARM RH Goupille		1	
12A- 8	V413-160-0120-0	WASHER/M12 Rondelle		1	
12A- 9	V500-153-0022-0	PIN, SPLIT/3 22 Goupille fendue		1	
12A-10	1365-402-0010-0	WIRE, THROTTLE Cable d'accélérateur	1	1	
12A-11	1376-402-0030-0	BAND, WIRE/140 Sangle	2	2	
12A-12	1380-401-0030-0	SPRING, CLUTCH Ressort	2	2	
12A-13	1364-404-0010-0	LEVER, LOCK Lever	1	1	
12A-14	1364-404-0020-0	WIRE, LOCK Cable	1	1	
12A-15	1364-404-0031-0	PIN, LOCK Axe	1	1	
12A-16	1364-404-0040-0	CASE, SPRING Carter de ressort	1	1	
12A-17	1364-404-0050-0	PIN, HEADED/6 19 Goupille	1	1	
12A-18	1326-401-0070-0	PIN, HEADED Goupille	1	1	
12A-19	V500-162-0014-0	PIN, SPLIT/2 14 Goupille fendue	2	2	
12A-20	3740-162-0050-0	WASHER/6.5 18 1 Rondelle	2	2	
12A-21	1364-404-0060-0	SPRING, PRESS/59 Ressort	1	1	
12A-22	V302-260-0060-0	NUT/M6 Erou	1	1	
12A-23	V200-260-6012-0	BOLT/M6 12 Vis	2	2	
12A-24	V401-160-0060-0	WASHER, SP/M6 Rondelle frein	2	2	
12A-25	V300-260-0060-0	NUT/M6 Erou	2	2	
12A-26	1380-401-2000-0	LEVER, CLUTCH Lever d'embrayage	1	1	
12A-27	3517-205-0070-0	WASHER Rondelle	2	2	
12A-28	3517-501-0110-0	SPRING, CLUTCH Ressort	1	1	
12A-29	1380-401-2101-0	ARM, CLUTCH RH Etrier G.	1	1	
12A-30	1380-401-2301-0	ARM, CLUTCH LH Etrier D.	1	1	
12A-31	1380-401-0010-0	PIN/75 Goupille	1	1	
12A-32	V500-153-0018-0	PIN, SPLIT/3 18 Goupille fendue	1	1	
12A-33	V413-160-0120-0	WASHER/M12 Rondelle	1	1	
12A-34	4106-105-3030-0	KNOB Poignée	1	1	
12A-35	1380-401-0021-0	WIRE, MAIN CLUTCH Cable	2	2	
12A-36	1375-621-2000-0	SWITCH, STOP ASSY Interrupteur	1	1	

Fig. 13

BONNET and FUEL TANK

Reservoir et capot

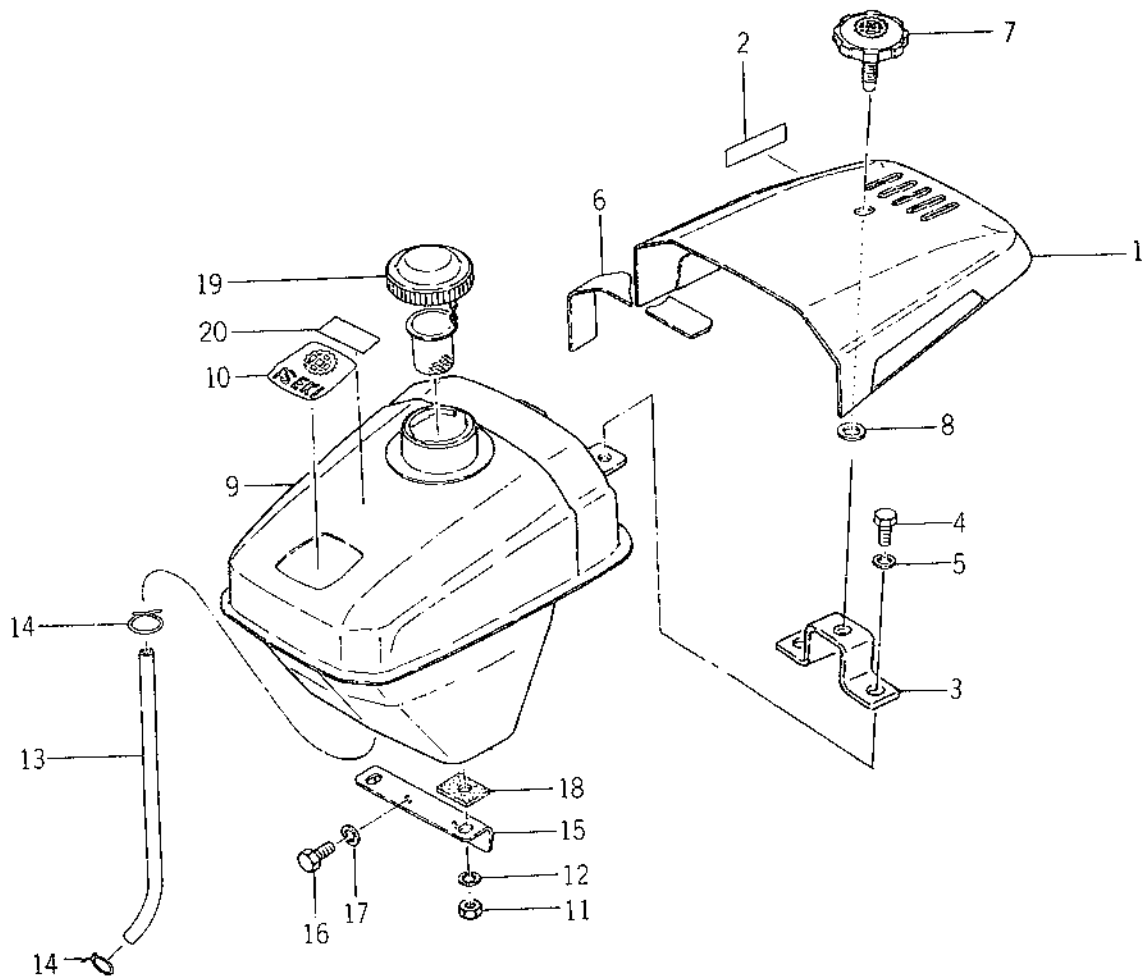

Ref No. Réf N°.	Parts No. Pièces N°.	Description Désignation	Model & Q'ty Modél & Quant		Remarks Remarques
			KC450	KC450F	
13- 1	1374-601-1000-0	BONNET Capot	1	1	
13- 2	1349-952-0010-0	MARK, CHOKE Etiquette	1	1	
13- 3	1374-601-2000-0	STAY, BONNET Calandre	1	1	
13- 4	V20126-100200	BOLT/M10×20 Vis	2	2	
13- 5	V40126-001000	WASHER, SP/M10 Rondelle frein	2	2	
13- 6	1349-601-0020-0	RUBBER, COVER Cale	1	1	
13- 7	1352-601-0020-0	KNOB, SET Bouton de capot	1	1	
13- 8	1352-601-0030-0	SUPPORT Support	1	1	
13- 9	1374-606-1000-0	TANK, FUEL Reservoir	1	1	
13-10	1329-902-0030-0	MARK, MASCOT Etiquette	1	1	
13-11	V30026-000800	NUT/M8 Erou	2	2	
13-12	V40126-000800	WASHER, SP/M8 Rondelle frein	2	2	
13-13	1374-606-0010-0	PIPE/RUBBER 7×10×143 Conduit	1	1	
13-14	V59013-091000	WIRE/0.9×100 Fil	2	2	
13-15	1374-606-0020-0	STAY, TANK Calandre	1	1	
13-16	V20126-080120	BOLT/M8×12 Vis	2	2	
13-17	V40126-000800	WASHER, SP/M8 Rondelle frein	2	2	
13-18	1349-606-0020-0	RUBBER, TANK Cale	2	2	
13-19	1352-600-0531-0	CAP, TANK Bouchon de reservoir	1	1	
13-20	2706-701-0140-0	MARK, LEADLESS Etiquette	1	1	No. 000001- FNo. 101501-

Fig. 14 BELT DRIVE
 Courroie intermediaire

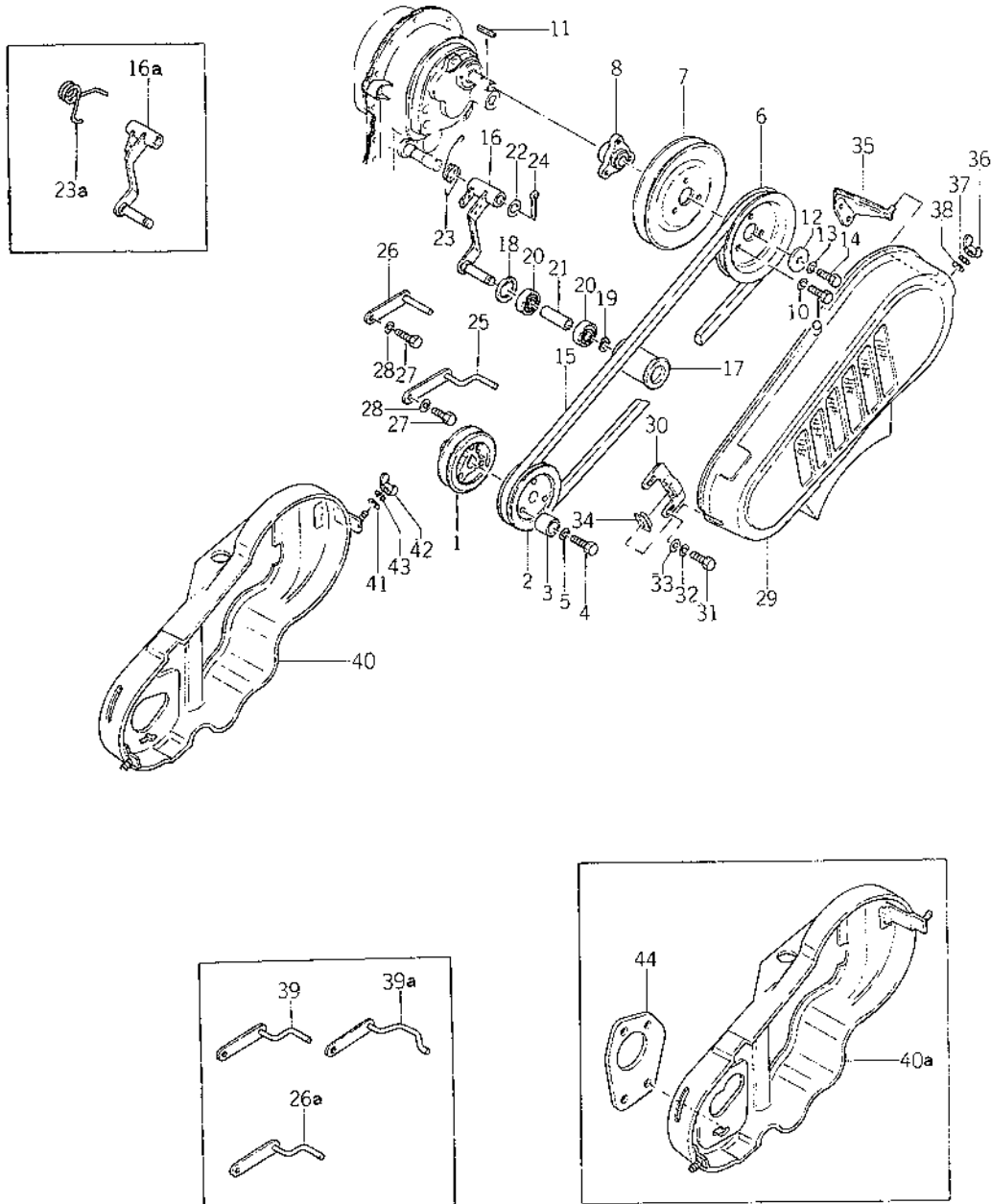

Ref No. Réf N°.	Parts No. Pièces N°.	Description Désignation	Model & Q'ty Modél & Quant		Remarks Remarques
			KC450	KC450F	
14- 1	1374-201-0010-0	PULLEY, ENGINE/77 Poulie motrice	1	1	
14- 2	1364-201-0021-1	PULLEY, ENGINE/106 Poulie motrice	1	1	
14- 3	1374-201-0020-0	SPACER Entretoise	1	1	
14- 4	V20126-080160	BOLT/M8×16 Vis	3	3	
14- 5	V40126-000800	WASHER, SP/M8 Rondelle frein	3	3	
14- 6	1364-201-0030-1	PULLEY, V/124 Poulie menee	1	1	
14- 7	1364-201-0040-1	PULLEY, V/150 Poulie menee	1	1	
14- 8	1364-201-0050-1	BOSS, PULLY Moyeu de poulie	1	1	
14- 9	V20126-080160	BOLT/M8×16 Vis	3	3	
14-10	V40126-000800	WASHER, SP/M8 Rondelle frein	3	3	
14-11	1329-201-0030-0	KEY, MAIN SHAFT Clavette	1	1	
14-12	1324-205-0020-0	WASHER, FOLLOWER Rondelle	1	1	
14-13	V40126-000800	WASHER, SP/M8 Rondelle frein	1	1	
14-14	V20126-080200	BOLT/M8×20 Vis	1	1	
14-15	V81720-003700	BELT, V/SB37 Courroie de reas	1	1	
14-16	1374-202-1000-0	ARM, TENSION Bras de tension	1	1	FNo. 100001-110740
14-16a	1375-202-2000-0	ARM, TENSION Bras de tension		1	FNo. 110741- FENo. 500001-
14-17	1374-202-0010-0	PULLEY, TENSION Gâlet tendeur	1	1	
14-18	V70510-003200	RING, SNAP/G32 Collet d'axe	1	1	
14-19	V70410-001200	RING, SNAP/G12 Collet d'axe	1	1	
14-20	V60014-062010	BEARING, RB/6201RS Roulement	2	2	
14-21	1329-202-0030-0	COLLAR, TENSION Collier	1	1	
14-22	3750-271-0050-0	COLLAR/15×20×2.3 Collier	1	1	
14-23	1364-202-0010-0	SPRING, TORQUE/28 Ressort	1	1	FNo. 100001-110740
14-23a	1373-202-0010-0	SPRING, TORQUE/37 Ressort		1	FNo. 110741- FENo. 500001-
14-24	V50015-300250	PIN, SPLIT/3×25 Goupille fendue	1	1	
14-25	1374-204-1000-0	STOPPER, BELT A Arret de courroie		1	FNo. 1-102850
14-25a	1374-205-2000-0	STOPPER, BELT A Arret de courroie	1	1	FNo. 102851-
14-25b	1374-206-2000-0	STOPPER, BELT A Arret de courroie	1	1	
14-26	1374-204-2000-0	STOPPER, BELT B Arret de courroie		1	FNo. 1-102850
14-26a	1374-205-2100-0	STOPPER, BELT B Arret de courroie	1	1	FNo. 102851-
14-26b	1374-206-2100-0	STOPPER, BELT B Arret de courroie	1	1	
14-27	V20126-080160	BOLT/M8×16 Vis	2	2	
14-27a	V20126-080200	BOLT/M8×20 Vis	2	2	
14-28	V40116-000800	WASHER, SP/M8 Rondelle frein		1	
14-29	1364-611-1000-0	COVER, BELT Carter de courroies		2	FNo. 1-102850
14-29a	1364-612-2000-0	COVER, BELT A Carter de courroies	1	2	FNo. 102851-
14-30	1374-204-3000-0	BRACKET, COVER Support		2	

Fig. 14 BELT DRIVE
 Courroie intermediaire

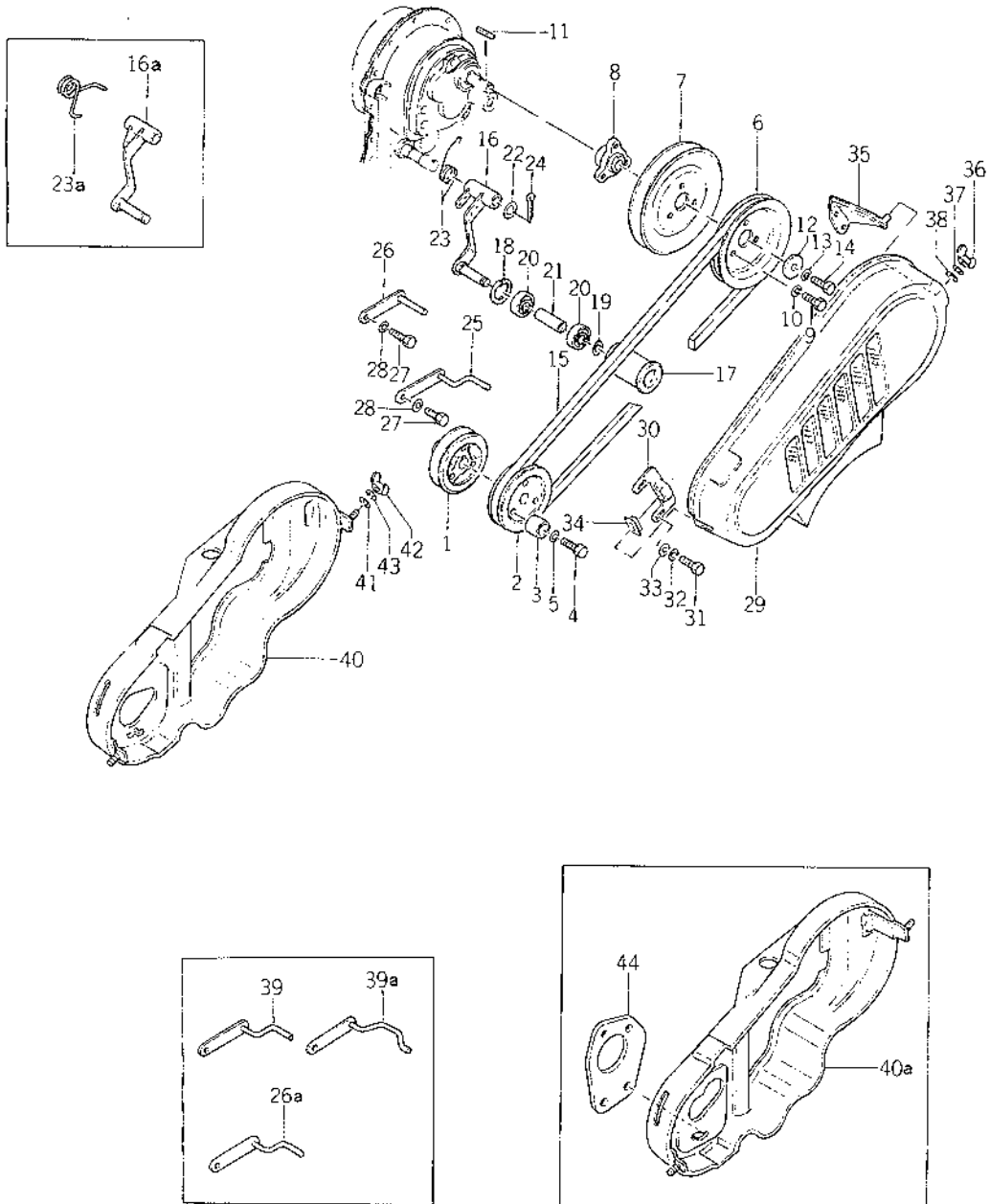

Ref No. Réf N ^o .	Parts No. Pièces N ^o .	Description Désignation	Model & Q'ty Modél & Quant		Remarks Remarques
			KC450	KC450F	
14-31	V20126-080160	BOLT/M8×16 Vis		2	
14-32	V40126-000800	WASHER, SP/M8 Rondelle frein		2	FNo. 1-102850
14-33	V41316-000800	WASHER/M8 Rondelle		2	
14-34	1329-611-0010-0	RUBBER, BELT COVER Cale		1	}
14-35	1364-611-3000-1	STAY, COVER Cavalier		1	
14-36	V37016-000800	NUT, WING/M8 Ecrou à oreilles		1	} FNo. 1-102850
14-37	V40126-000800	WASHER, SP/M8 Rondelle frein		1	
14-38	1352-616-0020-0	WASHER Rondelle		1	} FNo. 1-102850
14-39	1364-204-3000-0	STOPPER, BELT C Arret de courroie		1	
14-39a	1364-205-2200-0	STOPPER, BELT C Arret de courroie	1	1	FNo. 102851-
14-40	1364-612-2100-0	COVER, BELT B Carter de courroies	1	1	}
14-40a	1364-613-2000-0	COVER, BELT B Carter de courroie	1	1	
14-41	1352-616-0020-0	WASHER Rondelle	2	2	} FNo. 102851-
14-42	V37016-000800	NUT, WING/M8 Ecrou à oreilles	2	2	
14-43	V40116-000800	WASHER, SP/M8 Rondelle frein	2	2	
14-44	1364-613-0010-0	SPACER, COVER Entretoise	1	1	

Fig. 14A BELT DRIVE (W-type)
Courroie intermediaire

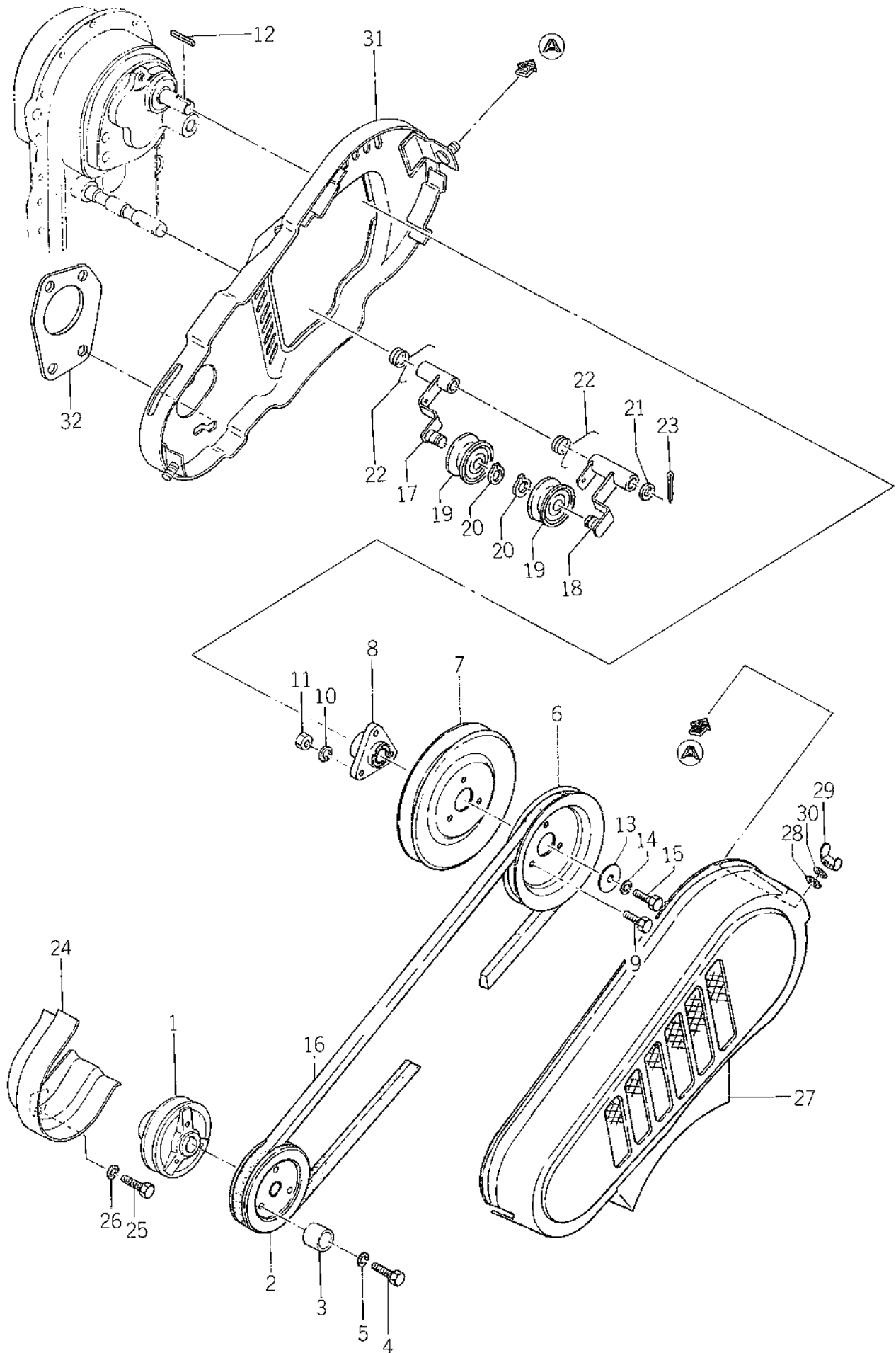

Ref No. Réf N°	Parts No. Pièces N°	Description Désignation	Model & Q'ty Modél & Quant		Remarks Remarques
			KC450	KC450F	
14A- 1	1375-261-0010-0	PULLEY, ENGINE/77 Poulie motrice	1	1	
14A- 2	1364-201-0021-0	PULLEY, ENGINE/106 Poulie motrice	1	1	
14A- 3	1374-201-0020-0	SPACER Entretoise	1	1	
14A- 4	V201-260-8016-0	BOLT/M8 16 Vis	3	3	
14A- 5	V401-260-0080-0	WASHER, SP/M8 Rondelle frein	3	3	
14A- 6	1364-201-0030-0	PULLEY, V/124 Poulie menee	1	1	
14A- 7	1364-201-0040-0	PULLEY, V/150 Poulie menee	1	1	
14A- 8	1373-261-0020-0	BOSS, PULLEY Moyeu de poulie	1	1	
14A- 9	V201-260-8020-0	BOLT/M8 20 Vis	3	3	
14A-10	V401-260-0080-0	WASHER, SP/M8 Rondelle frein	3	3	
14A-11	V300-260-0080-0	NUT/M8 Ecrin	3	3	
14A-12	1329-201-0030-0	KEY Clavette	1	1	
14A-13	1324-205-0020-0	WASHER Rondelle	1	1	
14A-14	V401-160-0080-0	WASHER, SP/M8 Rondelle frein	1	1	
14A-15	V201-260-8025-0	BOLT/M8 25 Vis	1	1	
14A-16	V817-200- 0390 -0	BELT, V/SB37 Courroie de reas	2	2	
14A-17	1373-262-2000-0	ARM, TENSION A Bras de tension	1	1	
14A-18	1373-262-2100-0	ARM, TENSION B Bras de tension	1	1	
14A-19	1352-202-3000-0	PULLEY, TENSION Galet tendeur	2	2	
14A-20	V704-140-0140-0	RING, SNAP/C 15 Collet d'axe	2	2	
14A-21	3750-271-0050-0	COLLAR Collier	1	1	
14A-22	1380-202-0010-0	SPRING, TORQUE/27 Ressort	2	2	
14A-23	V500-153-0025-0	PIN, SPLIT/3 25 Goupille fendue	1	1	
14A-24	1375-263-2000-0	STOPPER, BELT Arret de courroie	1	1	
14A-25	V201-260-8020-0	BOLT/M8 20 : Vis	2	2	
14A-26	V401-160-0080-0	WASHER, SP/M8 Rondelle frein	2	2	
14A-27	1373-651-2000-0	COVER, BELT A Carter de courroies	1	1	
14A-28	1352-616-0020-0	WASHER, CONE Rondelle	2	2	
14A-29	V370-160-0080-0	NUT, WING/M8 Ecrin a oreilles	2	2	
14A-30	V401-160-0080-0	WASHER, SP/M8 Rondelle frein	2	2	
14A-31	1373-651-2100-0	COVER, BELT B Carter de courroies	1	1	
14A-32	1364-613-0010-0	SPACER, COVER Entretoise	1	1	

Fig. 15

WHEEL and WHEEL PIPE
Roues

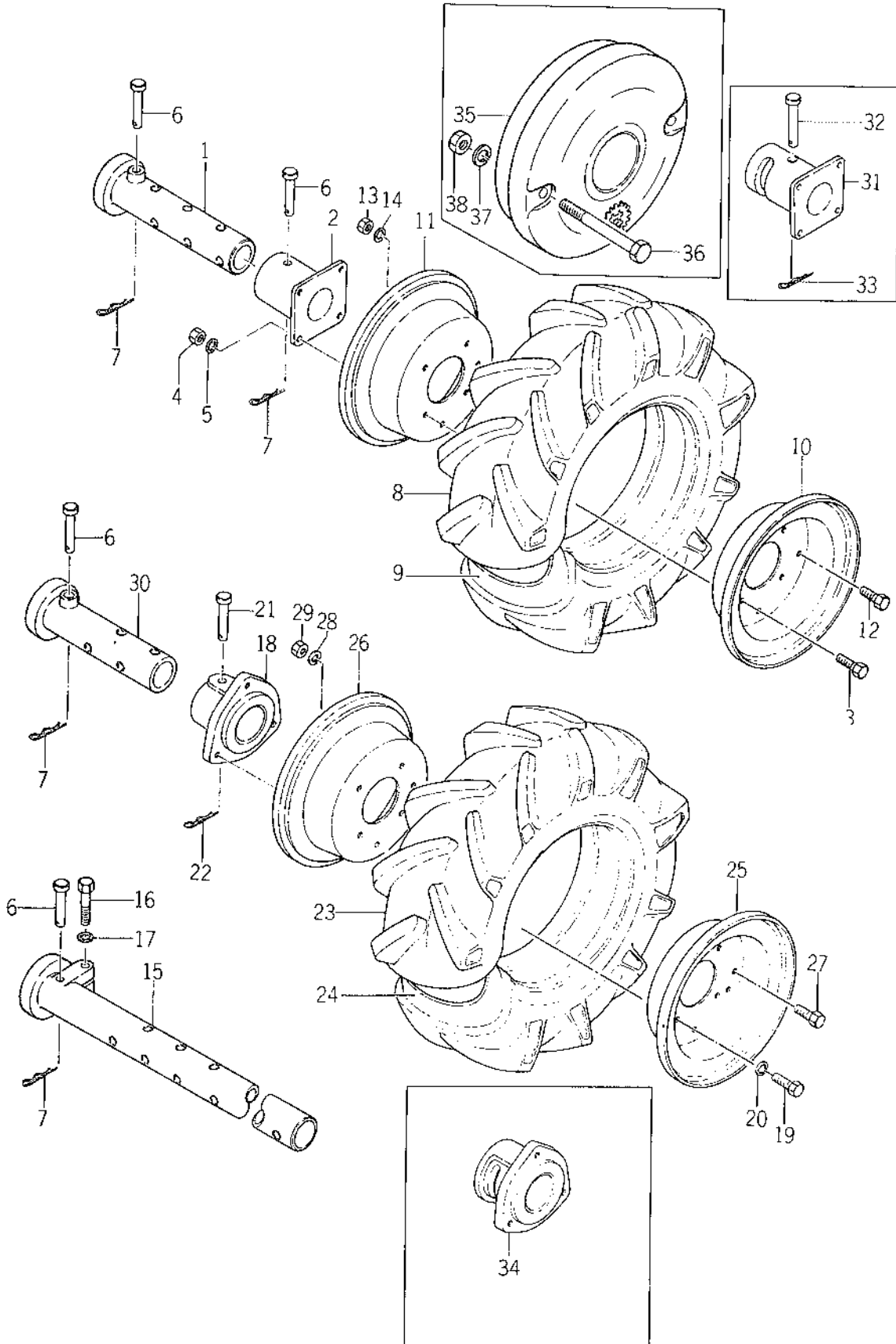

Ref No. Réf N°.	Parts No. Pièces N°.	Description Désignation	Model & Q'ty Modél & Quant		Remarks Remarques
			KC450	KC450F	
15- 1	1329-241-4000-0	PIPE, WHEEL/4 Tube rallonge	2	2	★
15- 2	1329-241-6000-1	FLANGE, WHEEL BOSS Boudin	2	2	★
15- 3	V20126-080200	BOLT/M8×20 Vis	8	8	★
15- 4	V30026-000800	NUT/M8 Erou	8	8	★
15- 5	V40116-000800	WASHER, SP/M8 Rondelle frein	8	8	★
15- 6	1310-241-0030-0	PIN, HEADED A Goupille	4	4	
15- 7	1305-241-0010-0	PIN, HAIR Attache beta	4	4	
15- 0-1	1329-200-9030-0	TIRE, LH ASSY/400-7 Roue, G.	1	1	★
15- 0-2	1329-200-9040-0	TIRE, RH ASSY/400-7 Roue, D.	1	1	★
15- 8	V88202-400070	·TIRE/2P 400-7 Pneu	2	2	★
15- 9	V88300-400070	·TUBE/400-7 Chambre a air	2	2	★
15- 0-3	1329-200-9020-0	·DRUM, WHEEL ASSY Jante ensemble	2	2	★
15-10	1329-241-0020-1	··DRUM, WHEEL Flasque	2	2	★
15-11	1329-241-0030-1	··DRUM, WHEEL Flasque	2	2	★
15-12	V20126-080160	··BOLT/M8×16 Vis	8	8	★
15-13	V30026-000800	··NUT/M8 Erou	8	8	★
15-14	V40126-000800	··WASHER, SP/M8 Rondelle frein	8	8	★
15-15	1331-253-3000-0	PIPE, WHEEL/430 Tube rallonge	2	2	★
15-16	V20126-120500	BOLT/M12×50 Vis	2	2	★
15-17	V40116-001200	WASHER, SP/M12 Rondelle frein	2	2	★
15- 0-4	1325-200-9010-0	BOSS, WHEEL ASSY Moyeu ensemble	6	2	★
15-18	1325-241-0010-2	·BOSS, WHEEL Moyeu	2	2	★
15-19	V20126-120200	·BOLT/M12×20 Vis	6	6	★
15-20	V40126-001200	·WASHER, SP/M12 Rondelle frein	6	6	★
15-21	1305-202-0060-0	PIN, HEADED Goupille	2	2	★
15-22	1305-241-0010-0	PIN, HAIR Attache beta	2	2	★
15- 0-5	1325-200-9030-0	TIRE, LH ASSY/400-9 Roue G.	1	1	★
15- 0-6	1325-200-9040-0	TIRE, RH ASSY/400-9 Roue D.	1	1	★
15-23	V88202-400090	·TIRE/2P 400-9 Pneu	2	2	★
15-24	V88300-400090	·TUBE Chambre a air	2	2	★
15- 0-7	1325-200-9020-0	·DRUM, WHEEL ASSY Jante ensemble	2	2	★
15-25	1325-241-0020-2	··DRUM, WHEEL Flasque	2	2	★
15-26	1325-241-0030-2	··DRUM, WHEEL Flasque	2	2	★
15-27	V20126-100160	··BOLT/M10×16 Vis	12	12	★
15-28	V40116-001000	··WASHER, SP/M10 Rondelle frein	12	12	★
15-29	V30026-001000	··NUT/M10 Erou	12	12	★
15-30	1364-241-1000-0	PIPE, WHEEL Tube rallonge	2	2	★
15-31	1364-241-4000-1	BOSS, FREE WHEEL B Moyeu	2	2	★

Ref No. Réf N°.	Parts No. Pièces N°.	Description Désignation	Model & Q'ty Modél & Quant		Remarks Remarques
			KC450	KC450F	
15-32	1305-202-0060-0	PIN, HEADED Goupille	2	2	★
15-33	1305-241-0010-0	PIN, HAIR Attache beta	2	2	★
15-34	1331-253-0010-1	BOSS, WHEEL Moyeu	2	2	★
15-35	1329-931-0020-1	WEIGHT, WHEEL/14 Masse pour roue	2	2	★
15-36	V20126-100950	BOLT/M10×95 Vis	4	4	★
15-37	V40126-001000	WASHER, SP/M10 Rondelle frein	4	4	★
15-38	V30026-001000	NUT/M10 Erou	4	4	★

Fig. 16 PULLEY, SCRATCH FENDER, FRONT HITCH and PARKING BRAKE
 Poulie, garde-boue, attelage et frein

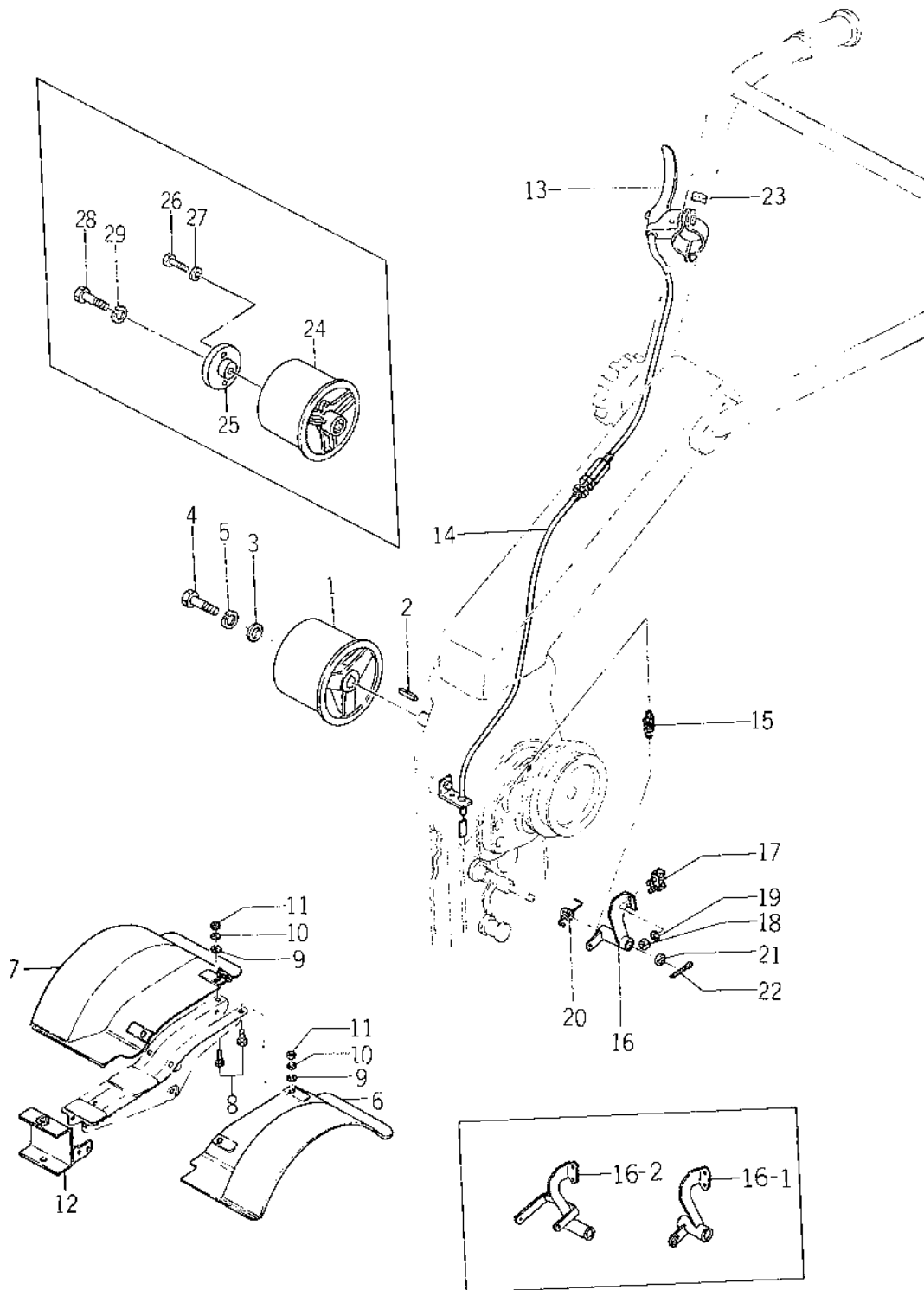

Ref No. Réf N°.	Parts No. Pièces N°.	Description Désignation	Model & Q'ty Modél & Quant		Remarks Remarques
			KC450	KC450F	
16- 1	1364-917-0011-0	PULLEY, FLAT/100 Poulie	1	1	
16- 2	1329-201-0030-0	KEY, MAIN SHAFT Clavette	1	1	
16- 3	1324-205-0020-0	WASHER, FOLLOWER Rondelle	1	1	
16- 4	V201-260-8020-0	BOLT/M8 20 Vis	1	1	
16- 5	V401-260-0080-0	WASHER, SP/M8 Rondelle frein	1	1	
16- 0-1	1364-061-2000-0	FENDER, PUDDLE SET Garde-boue	1	1	★
16- 6	1364-616-1000-1	• FENDER, PUDDLE LH Garde-boue, G.	1	1	★
16- 7	1364-616-2000-1	• FENDER, PUDDLE RH Garde-boue, D.	1	1	★
16- 8	V201-260-8016-0	• BOLT/M8 16 Vis	4	4	★
16- 9	V413-260-0080-0	• WASHER/M8 Rondelle	4	4	★
16-10	V401-260-0080-0	• WASHER, SP/M8 Rondelle frein	4	4	★
16-11	V300-260-0080-0	• NUT/M8 Ecrou	4	4	★
16-12	1364-111-1000-1	HITCH, F. Attelage	1		★
16-12-1	1364-111-1000-0	HITCH, F. Attelage		1	★
16- 0-2	1364-040-3001-0	BRAKE SET Frein ensemble	1	1	★
16- 0-3	1373-407-2000-0	BRAKE ASSY Frein ensemble		1	★
16- 0-4	1373-457-2000-0	BRAKE SET Frein ensemble	1	1	★ for W-type
16-13	1364-400-0521-0	• LEVER, BRAKE ASSY Levier de frein	1	1	★
16-13a	1364-407-2000-0	• LEVER, BRAKE ASSY Levier de frein	1	1	★
16-14	1364-407-0010-0	• WIRE, BRAKE Cable	1	1	★
16-15	1364-407-0020-0	• SPRING, BRAKE Ressort	1	1	★
16-16	1364-407-1000-1	• ARM, BRAKE Bras	1	1	★
16-16-1	1373-407-2100-0	• ARM, BRAKE Bras		1	★
16-16-2	1373-457-2100-0	• ARM, BRAKE Bras	1	1	★ for W-type
16-17	1351-203-0010-0	• SHOE, BRAKE Sabot de frein	1	1	★
16-18	V300-260-0060-0	• NUT/M6 Ecrou	2	2	★
16-19	V401-260-0060-0	• WASHER, SP/M6 Rondelle frein	2	2	★
16-20	1364-202-0010-0	• SPRING, TORQUE/28 Ressort	1	1	★
16-20-1	1373-407-2010-0	• SPRING, TORQUE/37 Ressort		1	★
16-20-2	1380-202-0010-0	• SPRING, TORQUE/27 Ressort	1	1	★ for W-type
16-21	3750-271-0050-0	• COLLAR Collier	1	1	★
16-22	V500-163-0025-0	• PIN, SPLIT/3 25 Goupille fendue	1	1	★
16-23	1364-952-0010-0	MARK, BRAKE Etiquette	1	1	★
16-24	1364-917-0013-0	PULLEY/100 Poulie	1	1	
16-25	1364-917-0031-0	PLATE Support	1	1	
16-26	V200-360-6020-0	BOLT/M6 20 7T Vis	2	2	spline-type
16-27	V401-160-0060-0	WASHER, SP/M6 Rondelle frein	2	2	
16-28	V201-460-8035-0	BOLT/M8 35 9T Vis	1	1	

Fig. 16 PULLEY, SCRATCH FENDER, FRONT HITCH and PARKING BRAKE
 Poulie, garde-boue, attelage et frein

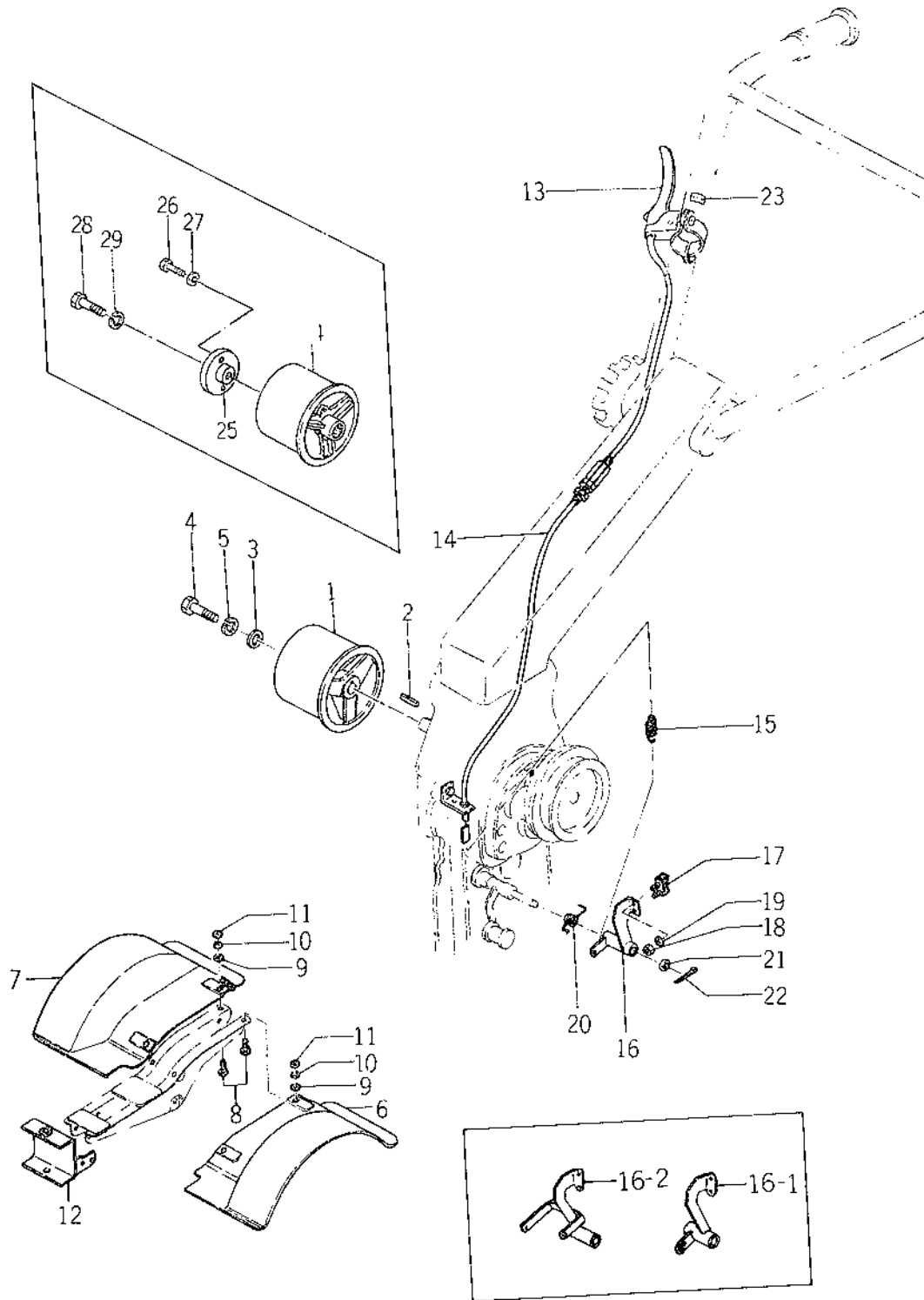

Ref No. Réf N°.	Parts No. Pièces N°.	Description Désignation	Model & Q'ty Modél & Quant		Remarks Remarques
16-29	V401-260-0080-0	WASHER, SP/M8 Rondelle frein	1	1	spline-type

Fig. 17 RECOIL STARTER
Lanceur

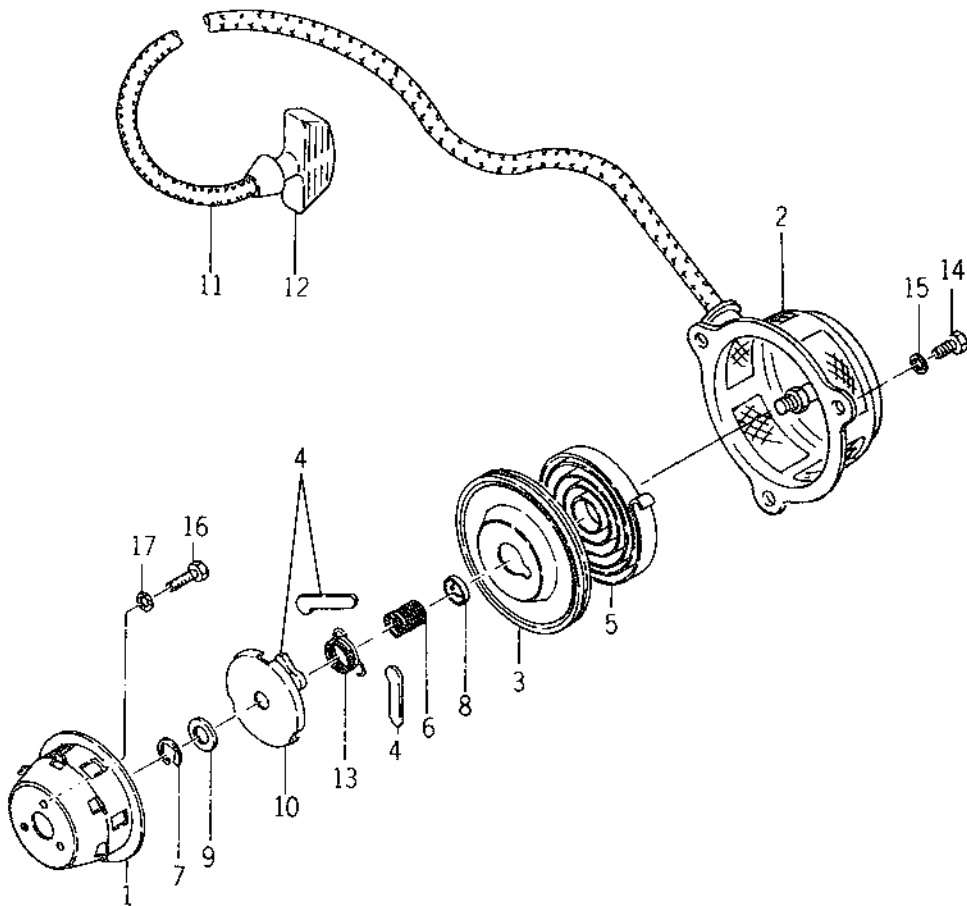

Ref No. Réf No.	Parts No. Pièces No.	Description Désignation	Model & Q'ty Modél & Quant		Remarks Remarques
			KC450	KC450F	
17- 1	1374-100-0510-0	STARTER, RECOIL ASSY Lanceur complet	1	1	FNo. 100001-110740
17- 1a	1374-151-2100-0	STARTER, RECOIL ASSY Lanceur complet	1	1	FNo. 110741- FENo. 500001-
17- 2	1374-121-0020-0	·CASE, STARTER Carter de lanceur	1	1	FNo. 100001-110740
17- 2a	1374-151-0010-0	·CASE, STARTER Carter de lanceur		1	FNo. 110741- FENo. 500001-
17- 3	1374-121-0030-0	·REEL Bobine	1	1	
17- 4	1374-121-0040-0	·RATCHET Cliquet	3	3	
17- 5	1374-121-0050-0	·SPRING, SPIRAL Ressort	1	1	
17- 6	1374-121-0060-0	·SPRING, FRICTION Ressort	1	1	
17- 7	1374-121-0070-0	·RING, SNAP/E Collet d'axe	1	1	
17- 8	1374-121-0080-0	·WASHER Rondelle	1	1	
17- 9	1374-121-0090-0	·WASHER, THRUST Rondelle	1	1	
17-10	1374-121-0100-0	·PLATE, FRICTION Disque	1	1	
17-11	1374-121-0110-0	·ROPE, STARTER Cordon	1	1	
17-12	1374-121-0120-0	·KNOB, STARTER Poignée	1	1	
17-13	1374-121-0130-0	·SPRING, RETURN Ressort de rappel	1	1	
17-14	V20026-060100	BOLT/M6 x 10 Vis	3	3	
17-15	V40126-000060	WASHER, SP/M6 Rondelle frein	3	3	
17-16	V20026-060150	BOLT/M6 x 15 Vis	3	3	
17-17	V40126-000060	WASHER, SP/M6 Rondelle frein	3	3	

Fig. 18 RECOIL STARTER
Lanceur

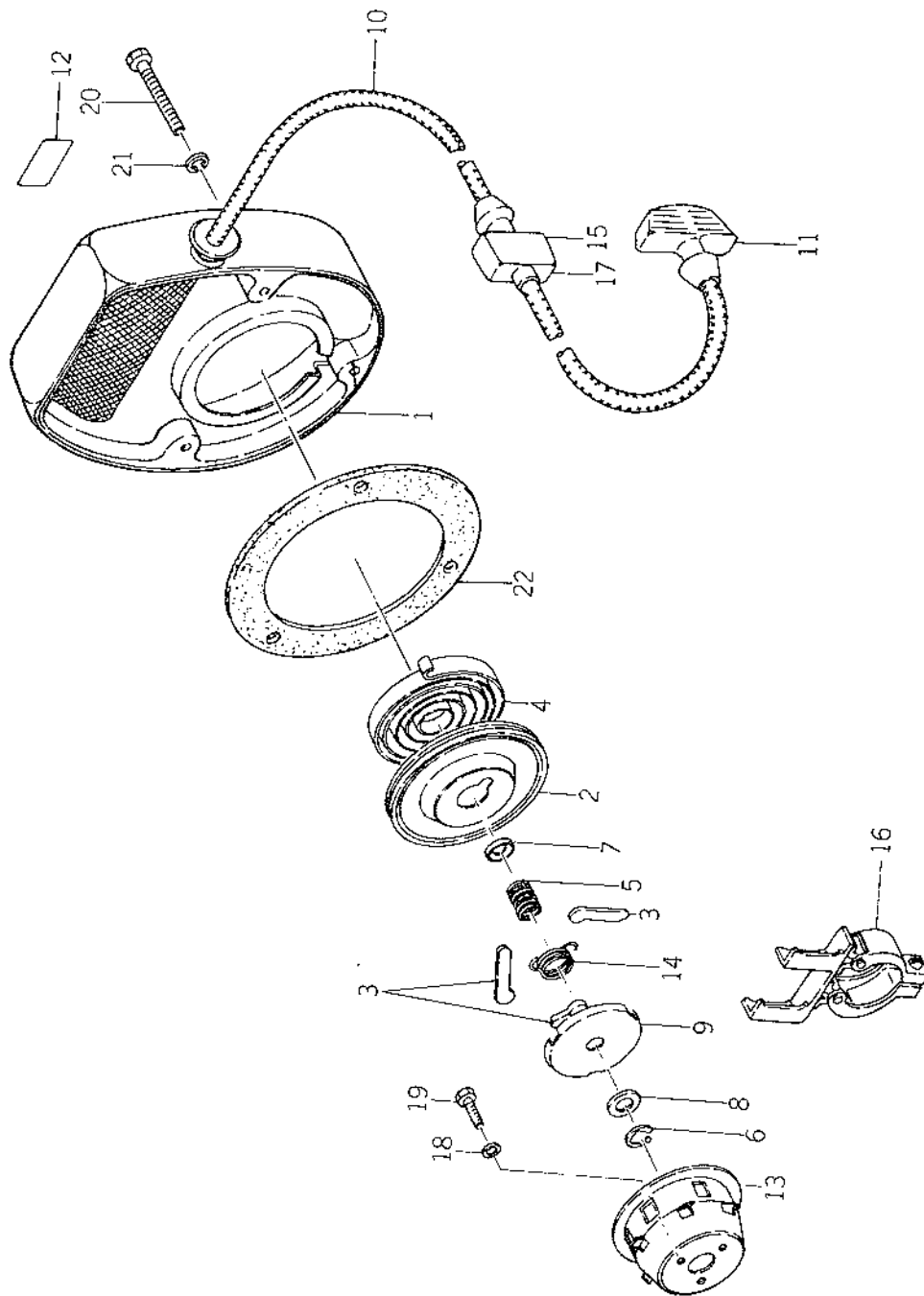

Ref No. Réf N°.	Parts No. Pièces N°.	Description Désignation	Model & Q'ty Modél & Quant		Remarks Remarques
			KC450	KC450F	
18- 0-1	1352-100-0510-0	STARTER, RECOIL ASSY Lanceur complet	1	1	
18- 1	1352-121-0020-0	·COUPLING, CASE Carter de lanceur	1	1	
18- 2	1352-121-0030-0	·COUPLING, REEL Bobine	1	1	
18- 3	1374-121-0040-0	·RATCHET Cliquet	3	3	
18- 4	1374-121-0050-0	·SPRING, SPIRAL Ressort spirale	1	1	
18- 5	1374-121-0060-0	·SPRING, FRICTION Ressort	1	1	
18- 6	V71020-000800	·RING, SNAP/E Collet d'axe	1	1	
18- 7	1374-121-0080-0	·WASHER Rondelle	1	1	
18- 8	1352-121-0040-0	·WASHER, THRUST Rondelle d'appui	1	1	
18- 9	1374-121-0100-0	·PLATE, FRICTION Disque	1	1	
18-10	1352-121-0050-0	·ROPE, STARTER Cordon	1	1	
18-11	1329-121-0140-0	·HANDLE Poignée	1	1	
18-12	1352-121-0090-0	·MARK, TRADE Etiquette	1	1	
18-13	1352-121-0120-0	·PULLEY, STARTER Poulie d'entraînement	1	1	
18-14	1374-121-0130-0	·SPRING, RETURN Ressort	1	1	
18-15	1352-121-0070-0	·CLIP, ROPE Coupelle	1	1	
18-16	1352-121-0080-0	·HOOK, WIRE Crochet de poignée	1	1	
18-17	1352-121-0060-0	·DAMPER Amortisseur	1	1	
18-18	V40126-000600	WASHER, SP/M6 Rondelle frein	3	3	
18-19	V20026-060160	BOLT/M6 × 16 Vis	3	3	
18-20	V20026-060650	BOLT/M6 × 65 Vis	3	3	
18-21	V40126-000600	WASHER, SP/M6 Rondelle frein	3	3	
18-22	1352-121-0010-0	PACKING Joint	1	1	

Fig. 19

TOOLS
Outils

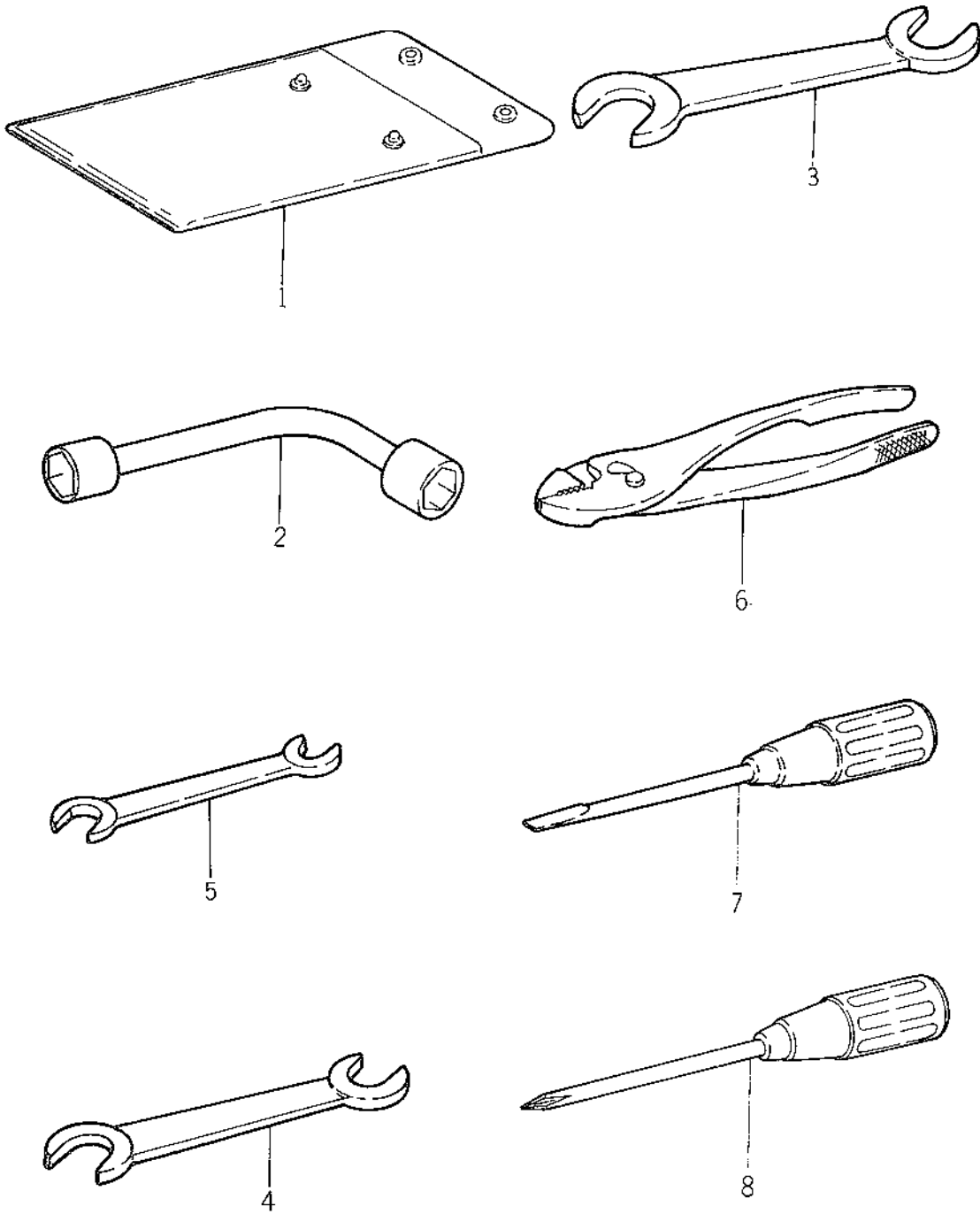

Ref No. Réf N°.	Parts No. Pièces N°.	Description Désignation	Model & Q'ty Modél & Quant		Remarks Remarques
			KC450	KC450F	
19- 1	1329-906-0011-0	BAG, TOOL Trousse a outils	1	1	
19- 2	1305-906-0010-0	SPANNER, BOX L-TYPE Cle a pipe	1	1	
19- 3	V92055-190220	SPANNER/19-22 Cle plate	1	1	
19- 4	V92055-130170	SPANNER/13-17 Cle plate	1	1	
19- 5	V92055-120140	SPANNER/12-14 Cle plate	1	1	
19- 6	V93625-001500	PLIERS/150 Pincés	1	1	
19- 7	V94014-061000	SCREWDRIVER Tournevis	1	1	
19- 8	V94514-061000	SCREWDRIVER Tournevis	1	1	

F 4. 0 1 , F 6 0 1
POUR KC 450 , 450F

Fig. 20

ROTARY BELT DRIVE
Courroie intermediaire

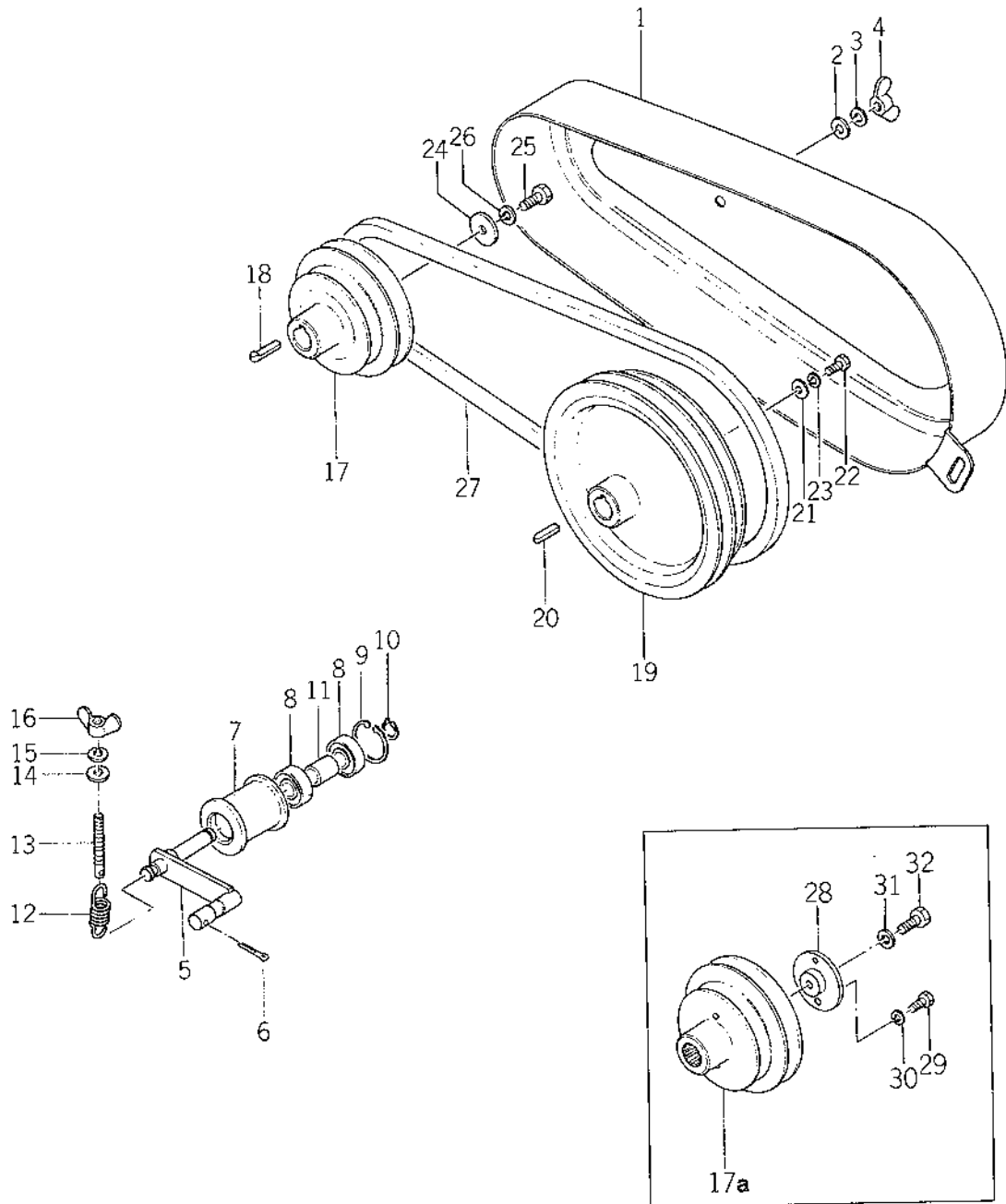

Ref No. Réf N°.	Parts No. Pièces N°.	Description Désignation	Model & Q'ty Modél & Quant		Remarks Remarques
			F40-1	F60-1	
20- 1	1364-701-1000-0	COVER, BELT Carter de courroies	1	1	★
20- 2	V41316-000800	WASHER/M8 Rondelle	2	2	★
20- 3	V40126-000800	WASHER, SP/M8 Rondelle frein	2	2	★
20- 4	1323-721-0070-0	NUT, WING/M8 Ecrou a oreilles	2	2	★
20- 5	1364-701-2000-0	ARM, TENSION Tirant	1	1	★
20- 6	V50015-300250	PIN, SPLIT/3×25 Goupille fendue	1	1	★
20- 7	1329-202-0011-4	PULLEY, TENSION Galet tendeur	1	1	★
20- 8	V60014-062010	BEARING, RB/6201RS Roulement	2	2	★
20- 9	V70514-003200	RING, SNAP/C32 Collet d'axe	1	1	★
20-10	V70414-001200	RING, SNAP/C12 Collet d'axe	1	1	★
20-11	1329-202-0030-4	COLLAR, TENSION Collier	1	1	★
20-12	1325-401-0090-0	SPRING, MAIN CLUTCH Ressort	1	1	★
20-13	1349-701-0010-0	BOLT, TENSION Vis	1	1	★
20-14	V41316-000800	WASHER/M8 Rondelle	1	1	★
20-15	V40126-000800	WASHER, SP/M8 Rondelle frein	1	1	★
20-16	1323-721-0070-0	NUT, WING/M8 Ecrou a oreilles	1	1	★
20-17	1364-701-0010-0	PULLEY, V/70-91 Rea	1	1	★
20-17a	1364-701-0012-0	PULLEY, V/70-91 Rea	1	1	★ spline-type
20-18	1329-201-0030-0	KEY, MAIN SHAFT Clavette	1	1	★
20-19	1349-701-0030-0	PULLEY, V/160-180 Rea	1	1	★
20-20	1329-917-0020-0	KEY, PULLEY Clavette	1	1	★
20-21	1337-701-0040-0	WASHER/7×21×3 Rondelle	1	1	★
20-22	V20026-060160	BOLT/M6×16 Vis	1	1	★
20-23	V40116-000600	WASHER, SP/M6 Rondelle frein	1	1	★
20-24	1324-205-0020-0	WASHER, FOLLOWER Rondelle	1	1	★
20-25	V20126-080200	BOLT/M8×20 Vis	1	1	★
20-26	V40116-000800	WASHER, SP/M8 Rondelle frein	1	1	★
20-27	V81720-003400	BELT, V/SB34 Courroie de reas	1	1	★
20-28	1364-917-0031-0	PLATE Plaque	1	1	★
20-29	V20036-060200	BOLT/M6×20 7T Vis	2	2	★
20-30	V40116-000600	WASHER, SP/M6 Rondelle frein	2	2	★ spline-type
20-31	V40116-000800	WASHER, SP/M8 Rondelle frein	1	1	★
20-32	V20146-080350	BOLT/M8×35 9T Vis	1	1	★

Fig. 21

REAR HITCH SYSTEM

Mecanisme de securite

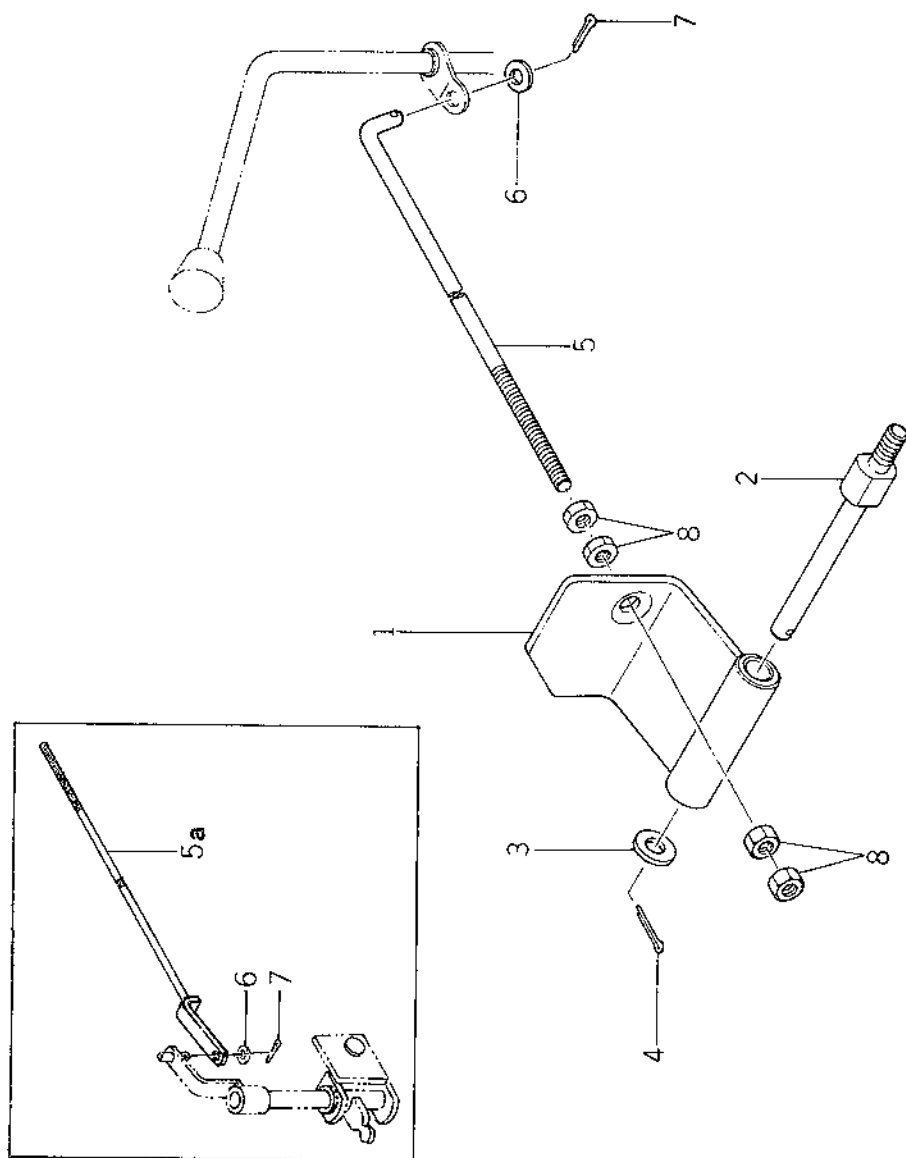

Ref No. Réf N°.	Parts No. Pièces N°.	Description Désignation	Model & Q'ty Modél & Quant		Remarks Remarques
			F40-1	F60-1	
21- 0-1	1364-702-0000-0	DEVICE, BACKPROOF ASSY Mecanisme de securite	1	1	★
21- 1	1364-702-2000-0	·ARM, BACKPROOF Bras	1	1	★
21- 2	1364-702-0010-0	·PIN, BACKPROOF ARM Axe	1	1	★
21- 3	V41316-001000	·WASHER/M10 Rondelle	1	1	★
21- 4	V50015-250200	·PIN, SPLIT/2.5×20 Goupille fendue	1	1	★
21- 5	1364-702-0020-0	·ROD Biellette	1	1	★
21- 5a	1364-702-2100-0	ROD Biellette	1	1	★
21- 6	V41316-000600	·WASHER/M6 Rondelle	1	1	★
21- 7	V50015-200200	·PIN, SPLIT/2×20 Goupille fendue	1	1	★
21- 8	V30026-000600	·NUT/M6 Ecroû	4	4	★

Fig. 22

ROTARY CHAIN CASE
Transmission de rotobineuse

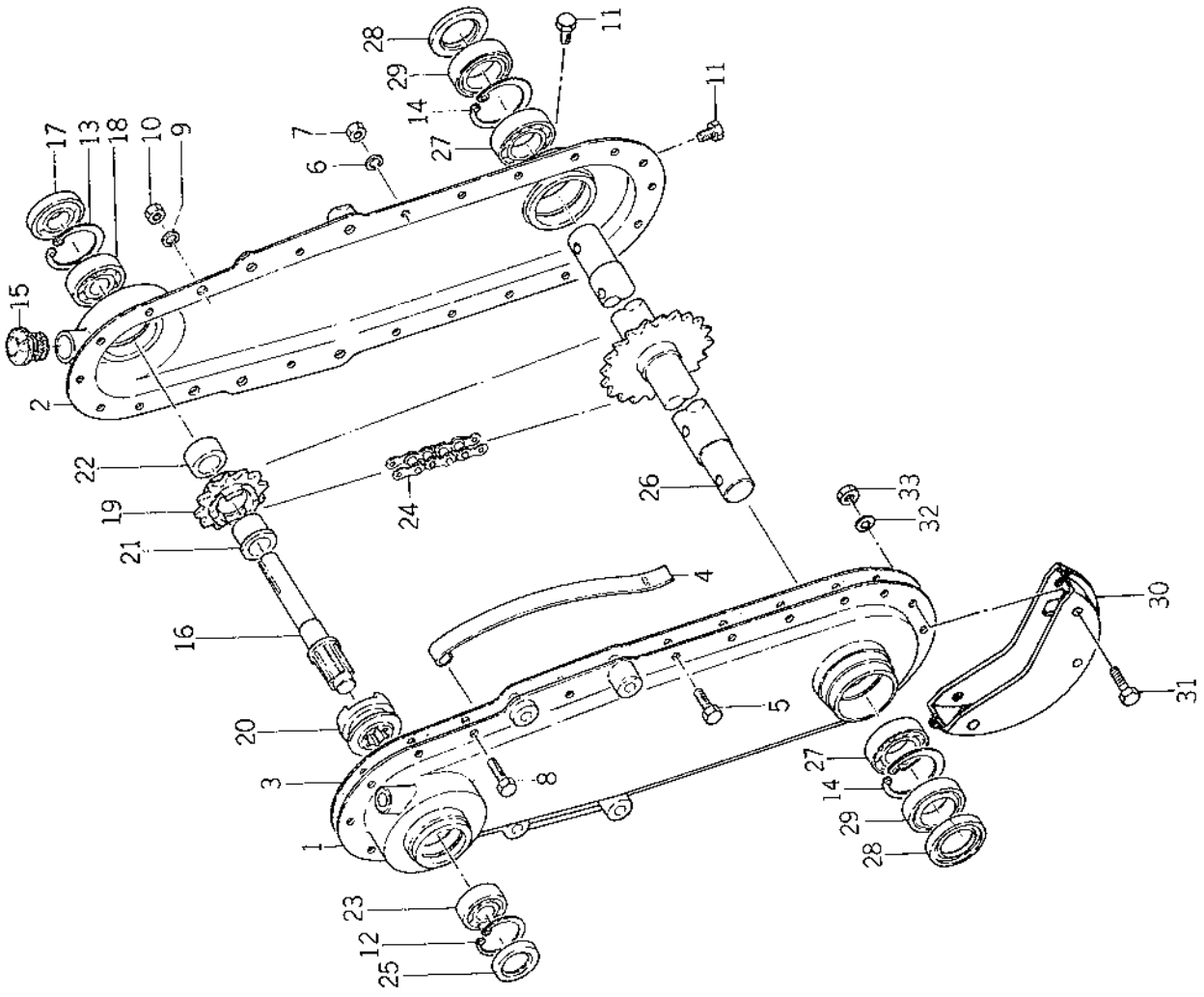

Ref No. Réf N°.	Parts No. Pièces N°.	Description Désignation	Model & Q'ty Modél & Quant		Remarks Remarques
			F40-1	F60-1	
22- 1	1349-706-1000-0	CASE, ROTARY CHAIN LH Carter de chaîne C.	1	1	★
22- 2	1349-706-2000-0	CASE, ROTARY CHAIN RH Carter de chaîne D.	1	1	★
22- 3	1349-706-0010-0	PACKING, ROTARY CHAIN Joint	1	1	★
22- 4	1337-706-0020-0	TENSION, CHAIN Tendeur	1	1	★
22- 5	V20026-060120	BOLT/M6×12 Vis	16	16	★
22- 6	V40116-000600	WASHER, SP/M6 Rondelle frein	16	16	★
22- 7	V30026-000600	NUT/M6 Erou	16	16	★
22- 8	V20126-080160	BOLT/M8×16 Vis	4	4	★
22- 9	V40116-000800	WASHER, SP/M8 Rondelle frein	4	4	★
22-10	V30026-000800	NUT/M8 Erou	4	4	★
22-11	1326-706-0020-0	PLUG, DRAIN Bouchon	2	2	★
22-12	V70514-004000	RING, SNAP/C-40 Collet d'axe	1	1	★
22-13	V70514-004700	RING, SNAP/C-47 Collet d'axe	1	1	★
22-14	V70514-005500	RING, SNAP/C-55 Collet d'axe	2	2	★
22-15	1366-706-0010-0	CAP, OIL/23 Bouchon	1	1	★
22-16	1337-708-0010-0	SHAFT, ROTARY TOP Arbre	1	1	★
22-17	V74012-047070	SEAL, OIL/SC20477 Bague d'étanchéité	1	1	★
22-18	V60011-062040	BEARING, RB/6204 Roulement	1	1	★
22-19	1349-708-0010-0	SPROCKET/12T Pignon	1	1	★
22-20	1337-708-0030-0	CLUTCH, ROTARY Embrayage	1	1	★
22-21	1337-708-0040-0	BUSH, SPROCKET Coussinet	1	1	★
22-22	1337-708-0050-0	COLLAR/21×30×9 Entretoise	1	1	★
22-23	V60011-062030	BEARING, RB/6203 Roulement	1	1	★
22-24	1337-708-0060-0	CHAIN, ROLLER Chaîne	1	1	★
22-25	1337-708-0070-0	COVER, METAL Couvercle	1	1	★
22-26	1349-709-1000-0	SHAFT, ROTARY Arbre de fraises	1	1	★
22-27	V60011-060060	BEARING, RB/6006 Roulement	2	2	★
22-28	V74213-055050	SEAL, OIL/VC30555 Bague d'étanchéité	2	2	★
22-29	V74413-055120	SEAL, OIL/TC305512 Bague d'étanchéité	2	2	★
22-30	1349-706-2100-0	PLATE, GUARD Plaque	1	1	★
22-31	V20046-060300	BOLT/M6×30 Vis	3	3	★
22-32	V40116-000600	WASHER, SP/M6 Rondelle frein	3	3	★
22-33	V30026-000600	NUT/M6 Erou	3	3	★

Fig. 23 ROTARY SHIFTER
Embrayage de rotobineuse

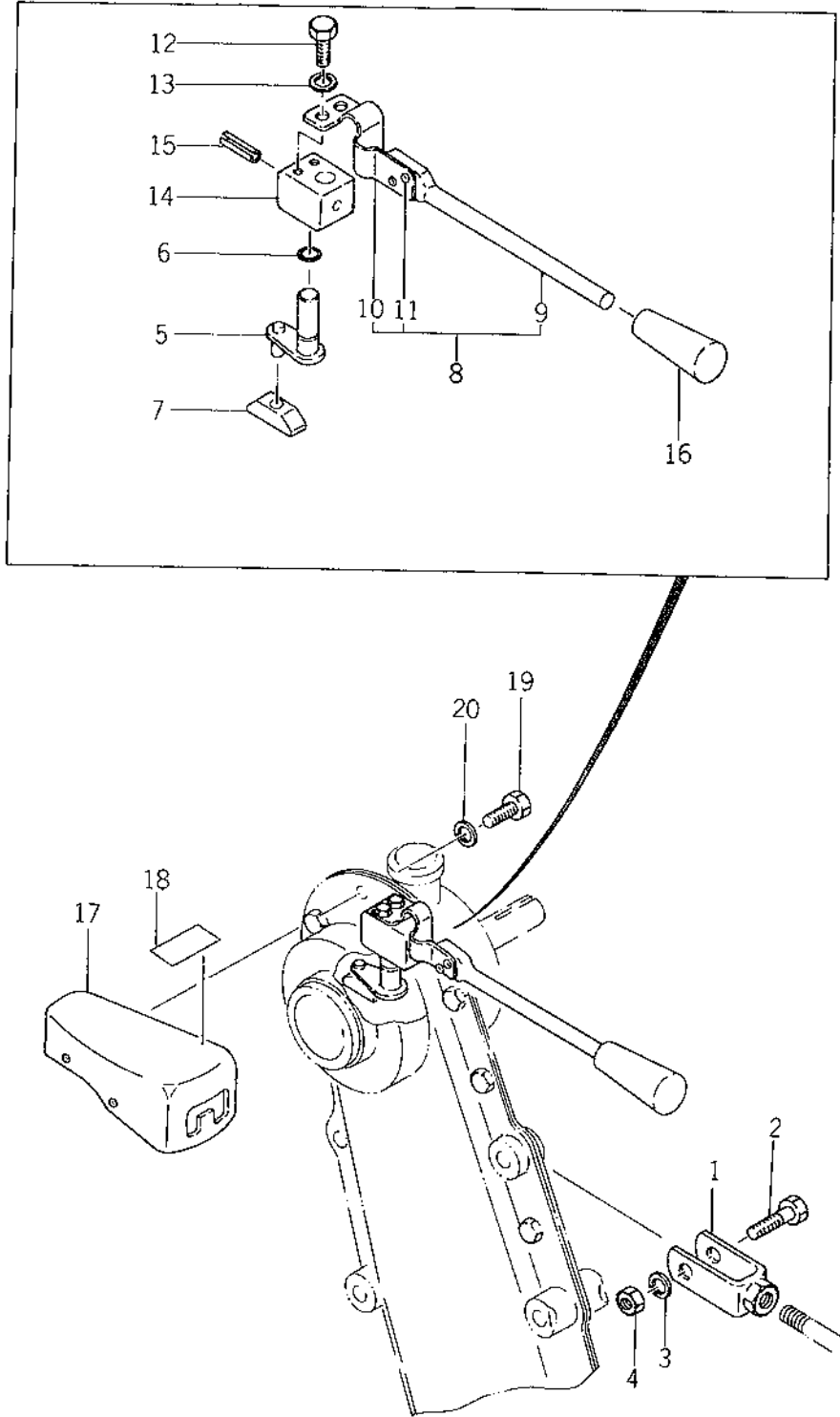

Ref No. Réf N°.	Parts No. Pièces N°.	Description Désignation	Model & Q'ty Modél & Quant		Remarks Remarques
			F40-1	F60-1	
23- 1	1337-706-3000-0	YOKE Chape	1	1	★
23- 2	V20126-100400	BOLT/M10×40 Vis	1	1	★
23- 3	V40116-001000	WASHER, SP/M10 Rondelle frein	1	1	★
23- 4	V30026-001000	NUT/M10 Ecrou	1	1	★
23- 5	1337-706-4001-0	ROD, SHIFTER Selecteur	1	1	★
23- 6	V72010-190090	O-RING/P9 Joint torique	1	1	★
23- 7	1340-229-0020-0	SHIFTER, SIDE CLUTCH Flcteur	1	1	★
23- 8	1337-706-5002-0	LEVER, CLUTCH ASSY Lavier d'embrayage	1	1	★
23- 9	1337-706-5051-0	LEVER (C) Lavier	1	1	★
23-10	1337-706-5060-0	SPRING, PLATE Ressort	1	1	★
23-11	V29010-300090	RIVET Rivet	2	2	★
23-12	V20126-060100	BOLT/M6×10 Vis	2	2	★
23-13	V40116-000600	WASHER, SP/M6 Rondelle frein	2	2	★
23-14	1337-706-0030-0	BOSS/25-25 Bossage	1	1	★
23-15	V58014-040250	PIN, SPRING/4×25 Goupille elastique	1	1	★
23-16	4106-105-3030-0	GRIP Poignee	1	1	★
23-17	1352-706-2100-0	GUIDE, CLUTCH Guide de commande	1	1	★
23-18	1349-956-0080-0	MARK, ROTARY CLUTCH Repere	1	1	★
23-19	V20026-060140	BOLT/M6×14 Vis	2	2	★
23-20	V40126-000600	WASHER/M6 Rondelle	2	2	★

Fig. 24 ROTARY PIPE
Fraise

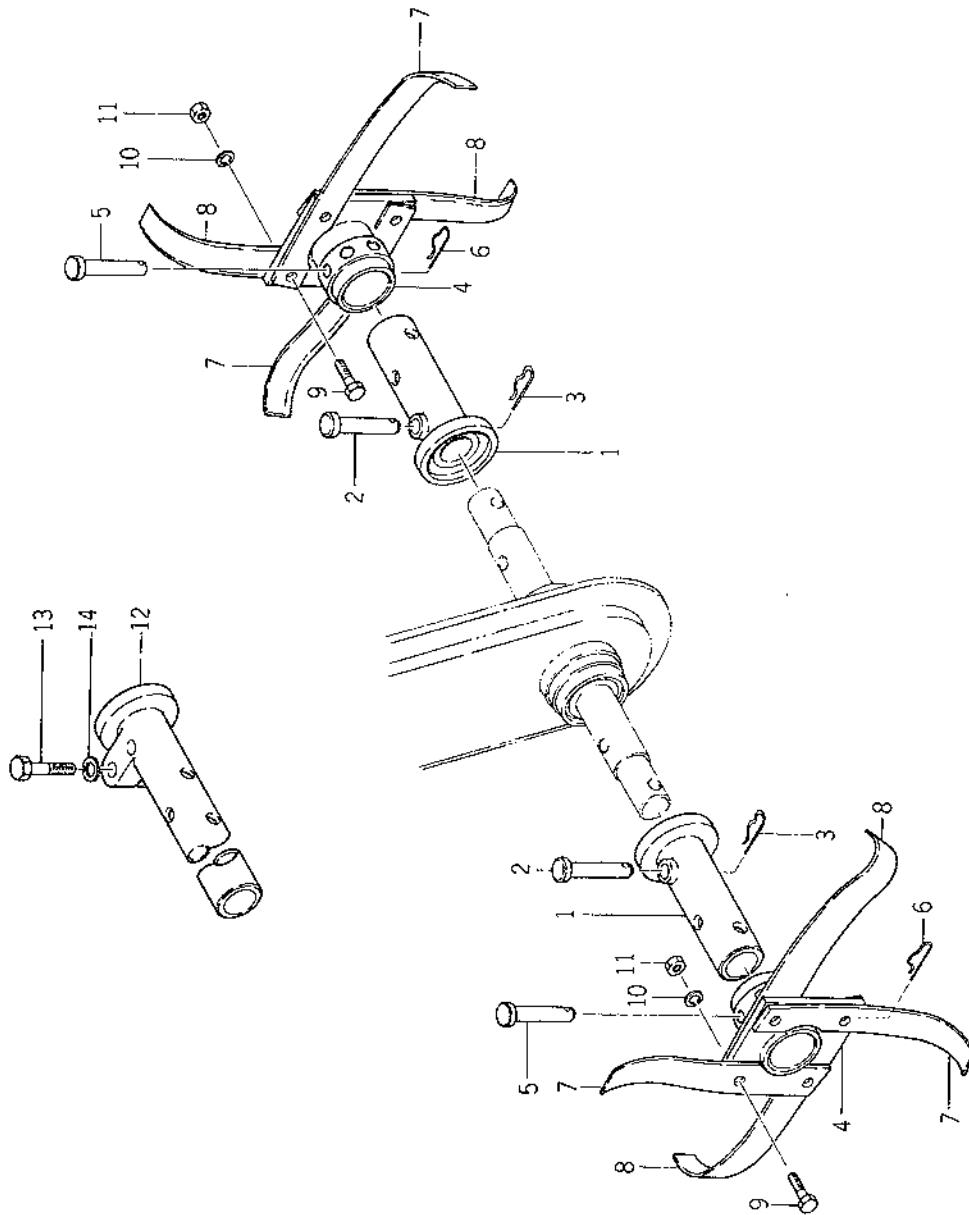

Ref No. Réf N°.	Parts No. Pièces N°.	Description Désignation	Model & Q'ty Modél & Quant		Remarks Remarques
			F40-1	F60-1	
24- 1	1329-241-3000-0	PIPE, WHEEL/2 Tube rallonge	2		★
24- 2	1310-241-0030-0	PIN, HEADED A Goupille	2	2	★
24- 3	1305-241-0010-0	PIN, HAIR Attache beta	2	2	★
24- 4	1349-716-1000-0	BOSS, BLADE SET Goupille de hoyau	2	4	★
24- 5	1305-202-0060-0	PIN, HEADED Goupille	2	4	★
24- 6	1305-241-0010-0	PIN, HAIR Attache beta	2	4	★
24- 7	1349-716-0010-0	BLADE, LH/C118 Hoyau G.	4	8	★
24- 8	1349-716-0020-0	BLADE, RH/C118 Hoyau D.	4	8	★
24- 9	V20126-080250	BOLT/M8×25 Vis	8	16	★
24-10	V40116-000800	WASHER, SP/M8 Rondelle frein	8	16	★
24-11	V30026-000800	NUT/M8 Ecrrou	8	16	★
24-12	1331-253-1000-0	PIPE, WHEEL/230 Tube rallonge		2	★
24-13	V20126-120500	BOLT/M12×50 Vis		2	★
24-14	V40116-001200	WASHER, SP/M12 Rondelle frein		2	★

Fig. 25 ROTARY FRAME
Enveloppe de rotobineuses

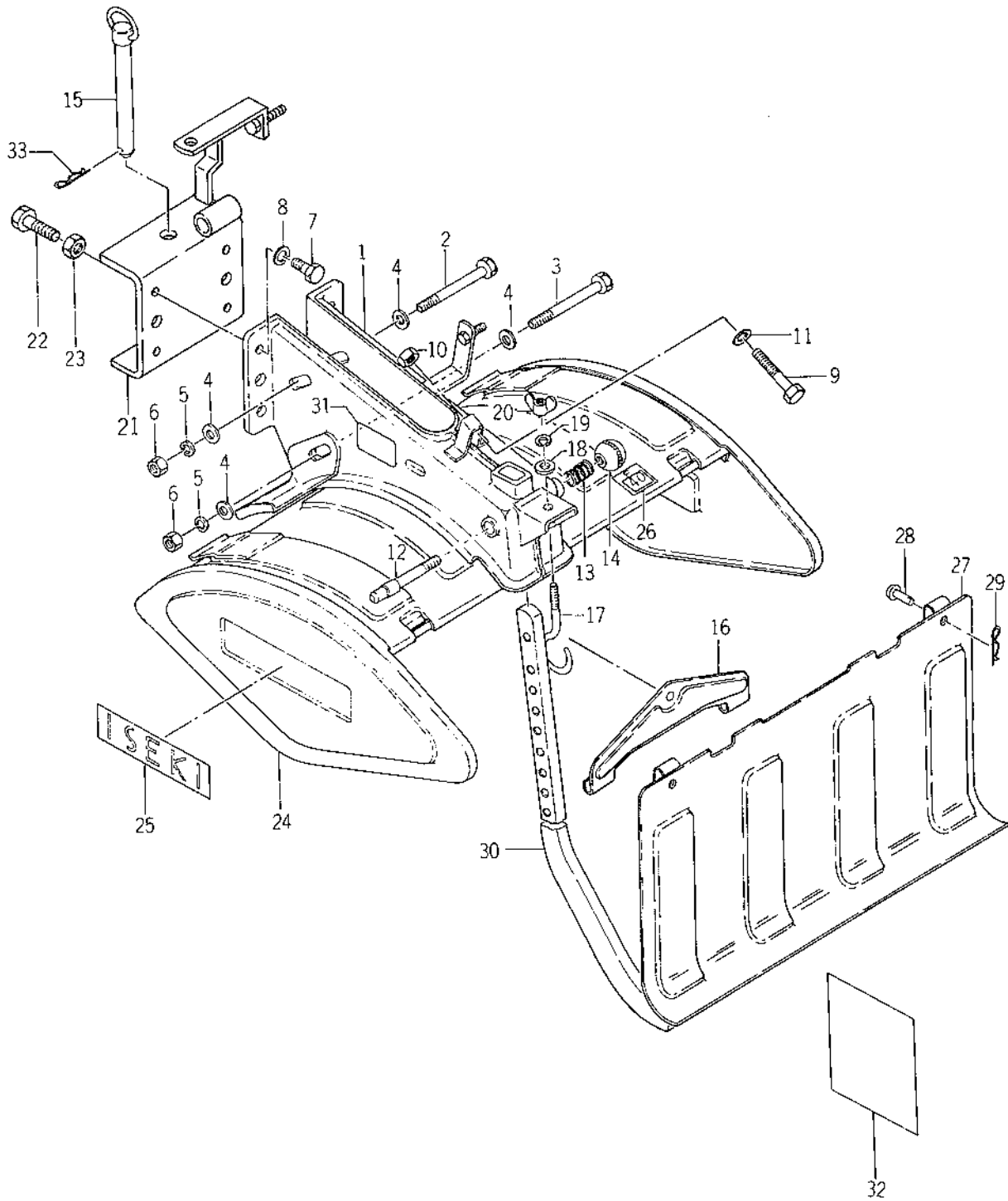

Ref No. Réf N°.	Parts No. Pièces N°.	Description Désignation	Model & Q'ty Modél & Quant		Remarks Remarques
			F40-1	F60-1	
25- 1	1349-721-1000-0	FRAME, ROTARY Chassis	1	1	★
25- 2	V20126-100900	BOLT/M10×90 Vis	2	2	★
25- 3	V20126-100950	BOLT/M10×95 Vis	1	1	★
25- 4	V41316-001000	WASHER/M10 Rondelle	6	6	★
25- 5	V40116-001000	WASHER SP/M10 Rondelle frein	3	3	★
25- 6	V30026-001000	NUT/M10 Ecrou	3	3	★
25- 7	V20126-100250	BOLT/M10×25 Vis	4	4	★
25- 8	V40116-001000	WASHER, SP/M10 Rondelle frein	4	4	★
25- 9	1349-721-0030-0	BOLT/M10×71 C-40 Vis	1	1	★
25-10	V30226-001000	NUT/M10 Ecrou	1	1	★
25-11	1337-721-0020-0	WASHER/11×24×3 Rondelle	1	1	★
25-12	1349-721-0010-0	PIN, ADJ Tenon	1	1	★
25-13	1350-311-0030-0	SPRING, PRESS/38 Ressort	1	1	★
25-14	1407-117-0031-0	KNOB, LEVER/31 Pommeau	1	1	★
25-15	1349-721-3100-0	PIN, KING/134 Goupille	1	1	★
25-16	1349-721-3000-0	HANGER, COVER Support	1	1	★
25-17	1349-721-0020-0	HOOK Crochet	1	1	★
25-18	V41316-000800	WASHER/M8 Rondelle	1	1	★
25-19	V40116-000800	WASHER, SP/M8 Rondelle frein	1	1	★
25-20	V37016-000800	NUT, WING/M8 Ecrou a oreilles	1	1	★
25-21	1364-722-1000-0	HITCH, ROTARY Attelage	1	1	★
25-22	V20126-120450	BOLT/M12×45 Vis	2	2	★
25-23	V30226-001200	NUT/M12 Ecrou	2	2	★
25-24	1349-723-1000-0	COVER, ROTARY/40 Bavolet	1		★
25-24-1	1349-756-1000-0	COVER, ROTARY/60 Bavolet		1	★
25-25	1326-953-0070-0	MARK, ISEKI Etiquette	1	1	★
25-26	1349-956-0010-0	MARK, TYPE/40 Etiquette	1		★
25-26-1	1349-956-0020-0	MARK, TYPE/60 Etiquette		1	★
25-27	1349-723-2000-0	GUARD, MUD Bavette	1		★
25-27-1	1349-756-2000-0	GUARD, MUD/60 Bavette		1	★
25-28	1349-723-0010-0	PIN/8×26 Goupille	2	2	★
25-29	1305-241-0010-0	PIN, HAIR Attache beta	2	2	★
25-30	1349-726-0010-0	SKID, CENTER Barre de profondeur	1	1	★
25-31	1349-956-0060-0	MARK, ROTARY OIL Etiquette	1	1	★
25-32	1364-955-0010-0	MANUAL, ASSEMBLING Manuel	1	1	★
25-33	1305-931-0030-0	PIN, HAIR Attache beta	1	1	★



**Yvan Béal - 21, av. de l'Agriculture - B.P. 16
Z.I. du Brézet - 63014 Clermont-Ferrand Cedex 2
Tél : 04 73 91 93 51 - Télécopie : 04 73 90 23 11
www.yvanbeal.fr - E-mail : info@yvanbeal.fr
R.C.S. Clermont-Fd B 304 973 886 - S.A.S. au capital de 612 000 €**