

ISEKI FRONT MOWERS

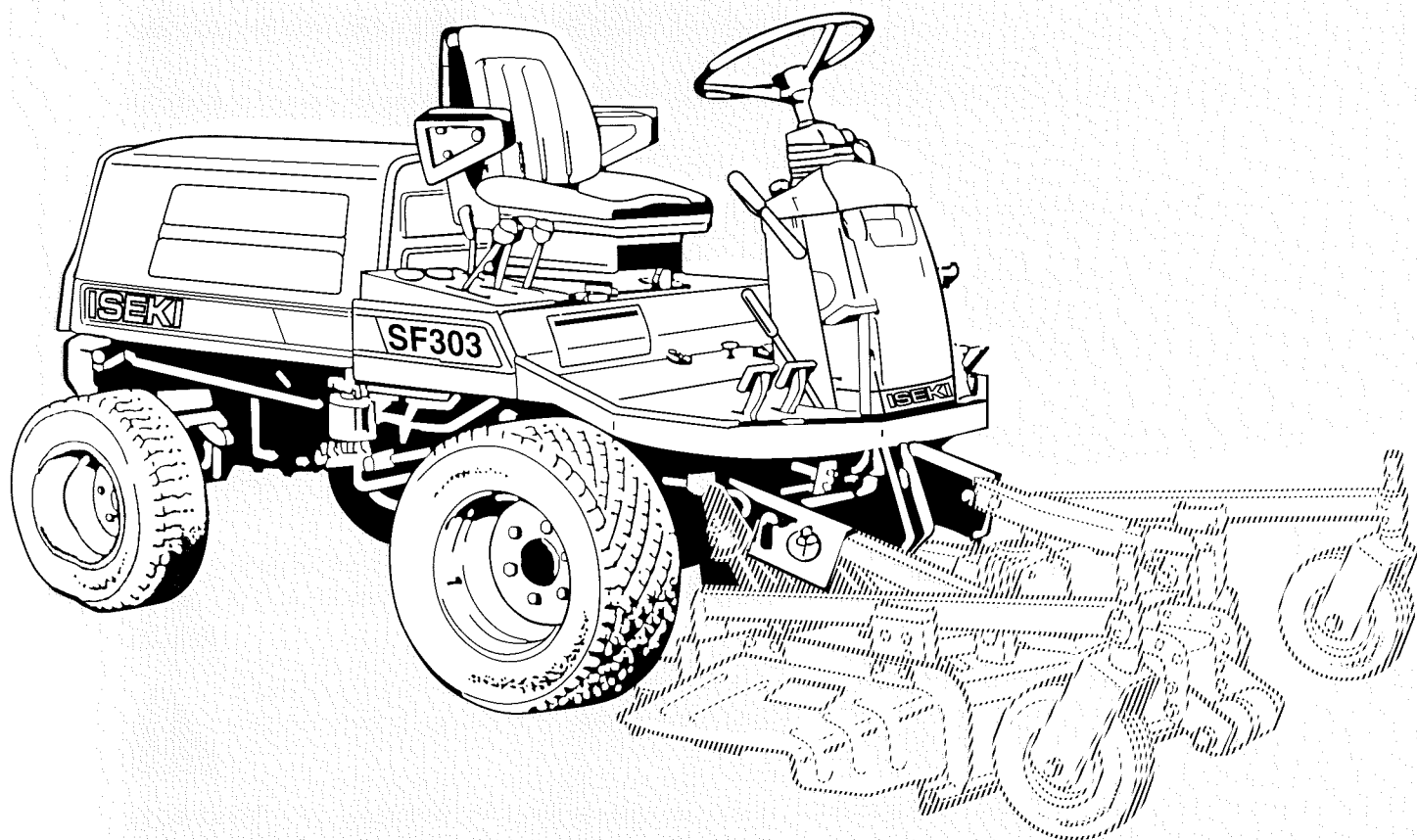

Operation Manual

MODELS:

SF303

SF333



ISEKI

SF303 & SF333

This manual explains about several types of the front mowers as listed below. Please confirm the type of your front mower by referring to the name plate.

		Auto 4WD	Rear Weight
SF333FH	UWE4M		○
	UXE4M	○	OPT
	UXWE4M	○	○
SF303FH	UWE4M		○
	UXE4M	○	OPT
	UXWE4M	○	○

All information, illustrations, and specifications contained in this manual are based on the latest information available at the time of publication

CONTENTS

INTORODUCTION	1	V. OPERATION.....	32
I. FOR SAFE OPERATION.....	4	1. BEFORE STARTING THE ENGINE	32
1. HOW TO BE A SAFE OPERATION.....	4	2. STARTING THE ENGINE	32
2. BEFORE STARTING THE FRONT MOWER	5	3. STOPPING THE ENGINE.....	34
3. OPERATION OF THEFRONT MOWER	6	4. OPERATION.....	36
4. OPERATION ON A SLOPE	8	4.1. MOVING TO A WORKING SITE.....	36
5. DRIVING ON PUBLIC ROADS	8	4.2. MOWING OPERATION	38
6. LOADING ONTO OR UNLOADING FROM A TRUCK:....	8	VI. MAINTENANCE	40
7. WHEN FILLING WITH FUEL:	9	1. INSPECTION AND ADJUSTMENT	40
8. MOUNTING AND DISMOUNTING OF THE MOWER DRIVE SHAFT ...	10	1.1. ENGINE OIL LEVEL	40
9. FRONT MOWER MAINTENANCE:	10	1.2. TRANSMISSION OIL LEVEL.....	41
10. ELECTRICAL SYSTEM	11	1.3. REDUCTION GEAR CASE OIL.....	41
11. TYRES AND WHEELS	13	1.4. REAR AXLE OIL LEVEL	42
12. BEFORE STORING THE FRONT MOWER	13	1.5. COOLANT LEVEL.....	42
13. LONG TERM STORAGE	14	1.6. FUEL LEVEL.....	43
II. SPECIFICATIONS	21	1.7. AIR-CLEANER.....	44
III. NAMES OF MAJOR COMPONENTS.....	22	1.8. FUEL STRAINER.....	44
VI. CONTROLS AND METERS	23	1.9. FAN BELT	45
1. CONTOROL PANEL	23	1.10. CLUTCH PEDAL PLAY.....	46
1.1. STARTER SWITCH	23	1.11. MASTER BRAKE PEDAL PLAY	46
1.2. GLOW INDICTOR.....	24	1.12. NEUTRAL POSITION OF HST	47
1.3. THROTTLE LEVER	24	1.13. INDEPENDENT BRAKE PEDALS (LH&RH)	49
1.4. HEAD LAMP SWITCH	24	1.14. BATTERY.....	49
1.5. MONITOR LAMP ARRAY	24	1.15. TYRE PRESSURE (INFLATION).....	50
2. FENDER (WING) PANEL	25	1.16. TOE-IN.....	50
2.1. TRANSMISSION RANGE SHIFT LEVER.....	25	2. REPLACEMENT OF OIL AND OIL FILTER.....	50
2.2. PTO LEVER.....	25	2.1. ENGINE OIL REPLACEMENT.....	50
2.3. LEFT LEVER.....	26	2.2. ENGINE OIL FILTER REPLACEMENT	51
2.4. CRUISE CONTROL LEVER	26	2.3. TRANSMISSION OIL REPLACEMENT	52
2.5. HOUR/TACHOMETER	26	2.4. REDUCTION GEAR CASE OIL REPLACEMENT ..	53
2.6. FUEL GAUGE	26	2.5. REAR AXLE OIL REPLACEMENT	54
3. CONTROL PEDALS AND LEVERS.....	27	3. RADIATOR INSPECTION AND CLEANING.....	55
3.1. CLUTCH PEDAL.....	27	3.1. RADIATOR CLEANING	55
3.2. MASTER BRAKE PEDAL	27	3.2. COOLANT REPLACEMENT	55
3.3. HST FORWARD TRAVEL PEDAL.....	28	4. INSPECTION OF FUSES AND WIRING	56
3.4. HST REVERSE TRAVEL PEDAL	28	5. ADJUSTMENT OF HYDRAULIC SYSTEM PARTS ..	57
3.5. INDEPENDENT BRAKE PEDAL (RH).....	28	VII. LUBRICATION CHART.....	58
3.6. INDEPENDENT BRAKE PEDAL (LH)	28	VIII. PERIODICAL INSPECTION TABLE.....	59
3.7. DIF-LOCK PEDAL.....	28	IX. TROUBLESHOOTING	60
4. PARKING BRAKE LEVER AND TILT LOCK LEVER...29		X. STRAGE	66
4.1. PARKING BRAKE LEVER	29	XI. ELECTRIC WIRING.....	67
4.2. TILT LOCK LEVER	29		
5. BONNET OPEN/CLOSE LEVER.....	29		
6. SAFETY SWITCHES	29		
7. WHEEL DRIVING MODE MANUAL MANUALLY CHANGE-OVER LEVER.....	30		
8. EXTERNAL HYDRAULIC CONTROL LEVERS (SF330-V).....	31		

I. FOR SAFE OPERATION

1. HOW TO BE A SAFE OPERATOR

1.1. Before starting the front mower for the first time, read this manual thoroughly and carefully. Especially abide by the instructions for safe operation. If you do not, it may result in bodily injuries.

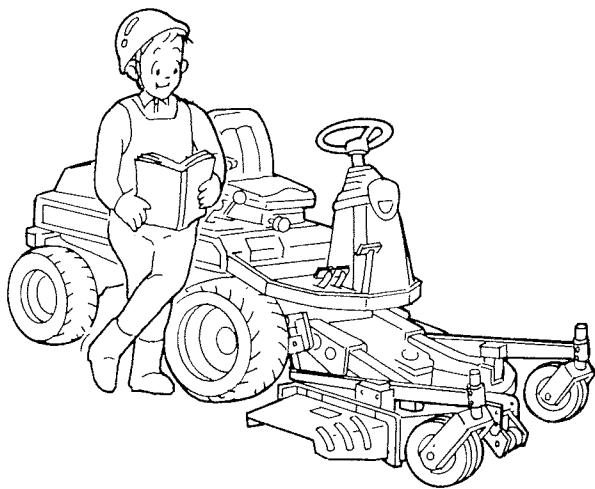

1.2. Pay attention to the caution labels on the front mower, mower deck and collector, and observe the instructions they give to avoid physical injuries.

1.3. Be sure to use necessary protective devices such as headgear, safety glasses, safety shoes, ear plugs, gloves, etc.

1.4. If you have consumed intoxicating beverages, are drowsy from medication, ill, or tired, never operate the front mower.



1.5. When operating, adjusting, or servicing the front mower, always wear substantial shoes and long trousers. Avoid wearing long loose clothes, accessories or letting long hair hang loose, which could be caught in rotating parts or on projections.

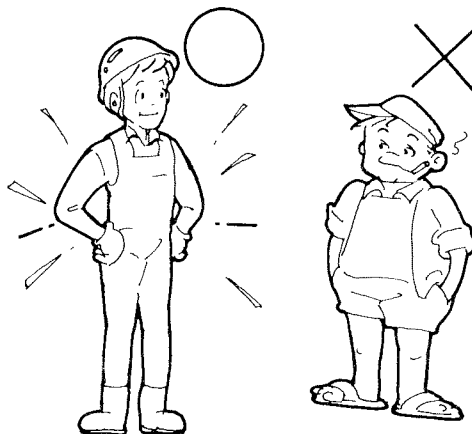

1.6. When you let someone else operate the front mower, instruct this person how to operate the front mower and also advise the reading of this manual. Never lend the mower to anyone who cannot understand the contents of this manual and safety labels. Operation of the front mower by a person unfamiliar with the front mower may lead to an unexpected accidents.

1.7. Never permit the following persons to operate the front mower:

- Persons not properly trained to operate the front mower
 - Persons who cannot understand the instructions mentioned in this operation manual and on the caution labels
 - Pregnant women
 - Children
- Local regulations may restrict the age of the operator.

1.8. Inspect the front mower periodically. If not, this

I. FOR SAFE OPERATION

may not only shorten the front mower's service life but also make safe and efficient operation impossible.

2. BEFORE STARTING THE FRONT MOWER

- 2.1. Set up an operation plan with sufficient time allowance. A tight plan may result in unexpected accidents. Especially when operating the front mower under extremely hot, cold, or humid circumstances, set up an operation schedule or method which will ensure operational safety.
- 2.2. Thoroughly inspect the area where the front mower is to be used and remove all stones, sticks, wires, and other foreign objects. Otherwise, they will be hit by the mower blades, which may lead to serious accidents.
- 2.3. The front mower is equipped with various safety systems. All safety shields, guards, and covers should always be in position and functioning properly.
- 2.4. Before starting the engine, make sure that everything is safe around the front mower and all control levers are in the neutral or off positions, the parking brakes applied, and the PTO lever in the OFF position. Otherwise, unexpected accidents may occur.
- 2.5. Start the engine with the starter switch only. Never attempt to start the engine by shorting the terminals, or the front mower may move abruptly, and result in unexpected accidents.
- 2.6. Never start the engine in a closed place. Exhaust fumes contain poisonous carbon monoxide, so sufficient ventilation should be provided when starting the engine indoors.
- 2.7. Make sure of safety around the front mower and move slowly when starting. Abrupt starting may cause unexpected accidents.
- 2.8. Become familiar with the operation, particularly, the stopping of the front mower. You should be skilful enough to be able to stop the front mower at will.
- 2.9. When your front mower is equipped with an implement other than a standard mower deck, such as a collector, a cabin, etc., never fail to ask your dealers about machine balance. Always follow their advice.
- 2.10. Keep in mind that the operator or user is responsible for the accidents or hazards caused by the front mower to other people or their property.
- 2.11. Especially before starting the mower, be sure to perform advised pre-operation inspections especially on the brakes and inspect visually to see that the blade and blade tightening nuts are not worn, damaged or loose. Replace worn or damaged blade and nuts as an assembly to preserve blade balance. Otherwise, poor braking or scattered broken blades may result, which is very dangerous.

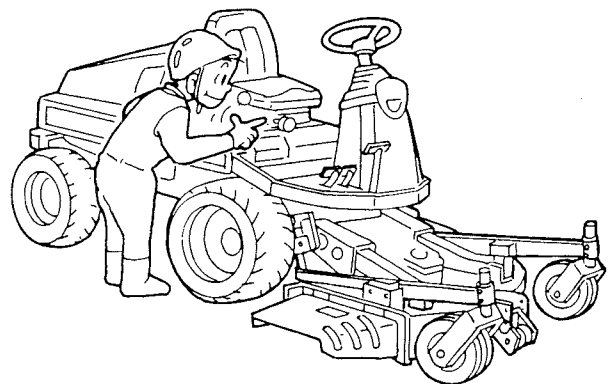
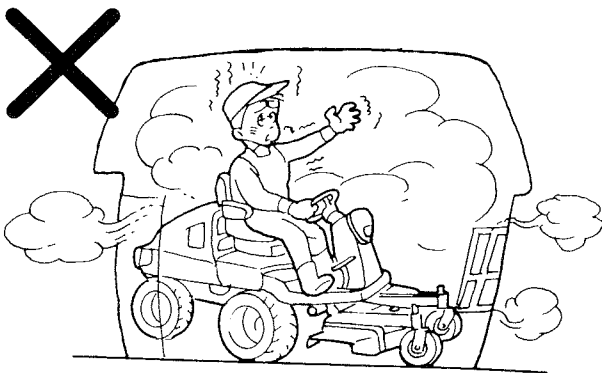

SF303 & SF333

3. OPERATION OF THE FRONT MOWER

3.1. During operation, never allow anyone, especially children, and animals to be in the vicinity of the front mower, especially near the discharge of the mower deck.



3.2. When you are working with co-workers, be sure to alert them by signalling before you take a new action.

3.3. Be sure to mow only in daylight. Mowing in the dark may cause unexpected accidents.

3.4. When operating the front mower, you should be seated in the operator's seat properly, hold the steering wheel by both hands, and look in the direction in which the front mower advances. Avoid looking aside or holding the steering wheel by one hand during operation.

3.5. Always be sure to operate the front mower from the driver's seat. Never attempt to get on or off the front mower while it is travelling.

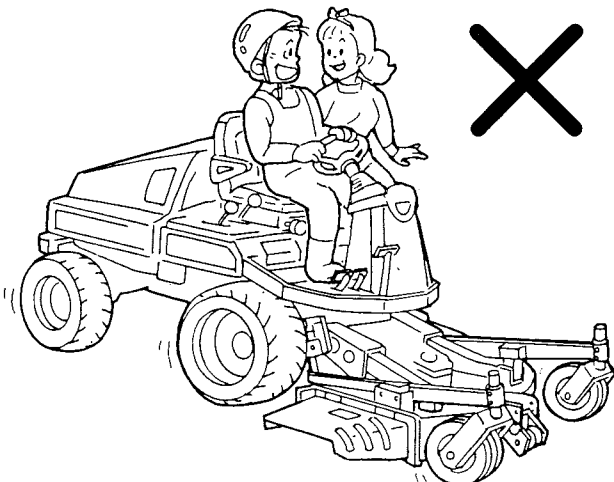

3.6. Never allow other persons to get on the front mower during operation.

3.7. When turning the front mower, slow down sufficiently. Turning at high speed may cause the front mower to turn over.

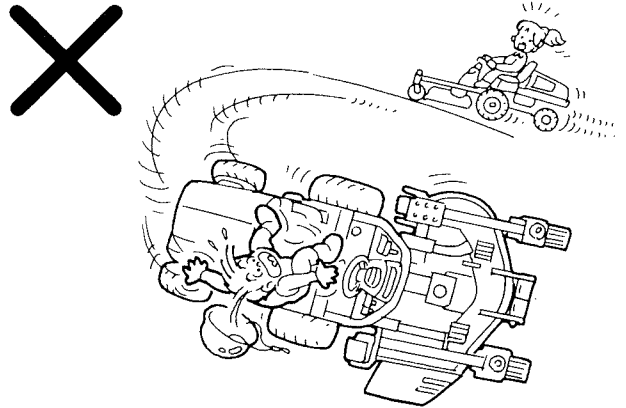

3.8. Never attempt to depress the dif-lock pedal while turning around the front mower. Turning with the dif-lock on may cause the front mower to turn over.

3.9. Connect the independent brake pedal except necessary situation. Never operate the independent brake pedal during travelling as this will cause the front mower to skid sideways or turn over. When stopping, be sure to use the master brake pedal.

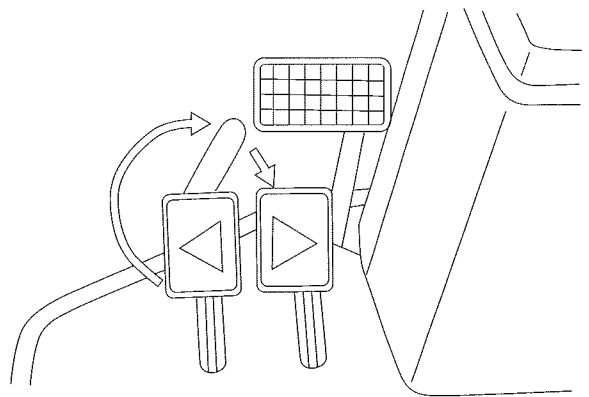

I. FOR SAFE OPERATION

3.10. When reversing the front mower, make sure of the safety conditions behind.

3.11. Never operate the front mower in terrain where there are ditches, holes, or steps easy to collapse. In such a place, the front mower could turn over or fall.

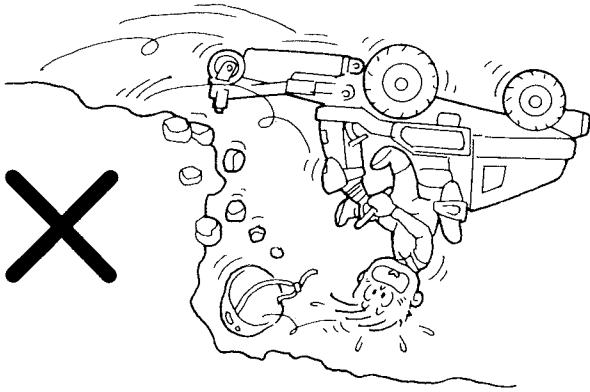

3.12. Before making access to moving parts, stop the engine, and keep your hands, feet, clothing, accessories and etc. away so as not to be caught in the moving parts of the front mower.

3.13. Always pay attention in front of the front mower to avoid obstacles such as corner stones, stubs, sprinkler heads, etc. When there is an obstacle that cannot be removed, provide a marker flag as a warning to keep away from it when mowing. When approaching the obstacle, slow down the front mower sufficiently to avoid it.

3.14. Never rest a foot on the brake and clutch pedal. If so, the brakes and clutch disc wear rapidly, which may lead to serious accidents.

3.15. Travelling set with the cruise lever should be restricted only to operations in spacious, flat areas with an unobstruted view.

3.16. Never attempt to do the mowing operation without the discharge cover in place or with the cover left open.

3.17. Never attempt to operate without the drive shaft cover in place.

3.18. Adjust the cutting height with the gauge wheels in accordance with the condition of the ground surface at the working site. Mowing on rough ground with low cutting height may cause the blades to hit soil or stones, which is very dangerous.

3.19. After striking a foreign object, stop the engine and inspect the front mower and the mower deck for damage and be sure to make repairs before mowing again.

3.20. Be sure to keep the grass discharging part clean. A clogged discharging part may cause the discharge cover to open, resulting in scattering of grass and stones, which is very dangerous.

3.21. Never allow grass or leaves to accumulate around heated parts such as the engine and the muffler, or this may cause a fire.

3.22. Before moving the front mower to another place, be sure to stop the mower blades and lift up the mower deck. Otherwise, they may hit stones and scatter them around, which is very dangerous.

3.23. When driving over a levee or a step, stop the mower blades, lift up the mower deck, and move the front mower straight to the levee and make it climb over slowly. Avoid climbing over a levee too high, or the front mower may fall sideways or turn over.

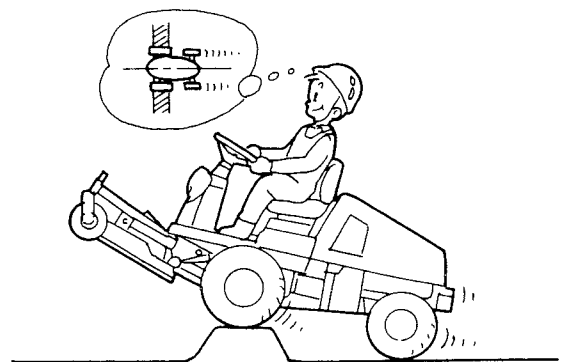

3.24. Before stopping the engine, be sure to lower the mower deck onto the ground, apply the parking brakes, and shift the PTO lever to the OFF position.

SF303 & SF333

3.25. Before leaving the front mower, stop the engine, lower the mower deck onto the ground, draw the engine key, apply the parking brakes, and chock the wheels. The front mower should be parked in a place which is flat and spacious, and has hard surface in order to avoid unexpected moving of the front mower.

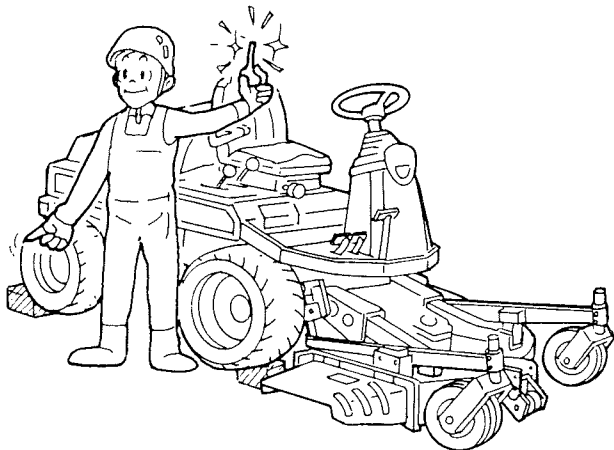

3.26. Never attempt to use the front mower to draw an implement or a trailer. It is not designed to draw a load.

4. OPERATION ON A SLOPE

We cannot recommend this front mower be operated on a slope, but advise you to use a front mower designed for slope operation. On a slope, various elements of operation such as slope angles, ground conditions, way of operation, grass conditions, etc. may lead to slipping, or over-turning of the front mower, which may result in bodily injury.

If the front mower has to be used on a slope, remember there is no such thing as a “safe” slope. Never use it on a slope of more than “10°”, and be sure to abide by the following instructions. Even if using it on a slope of less than “10°”, be sure to abide by the following instructions.

- A slope angle of 10° is specified with the front mowers equipped with the attachments mentioned respectively.

When your front mower is equipped with an implement other than standard, such as a collector, a cabin, etc., never fail to ask your dealers

about machine balance. Always follow their advice.

- The front mower is not equipped with any attachments or a cabin.
- The front mower is equipped with a standard mower deck.

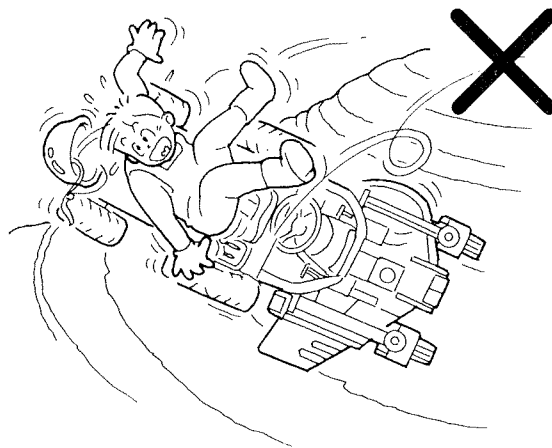

- 4.1. Be sure to wear a helmet during operation.
- 4.2. Be sure to shift the 4WD lever to the 4WD position.
- 4.3. Operate at sufficiently low speeds.
- 4.4. When turning, be sure to slow down sufficiently.
- 4.5. Avoid sudden starting and stopping.
- 4.6. Operate the front mower up and down across the contour lines of the hill. Never operate along the contour lines.
- 4.7. Never perform mowing operation on wet grass.
- 4.8. Never use the cruise control during mowing operation.
- 4.9. Never park the front mower on a slope.
- 4.10. Never shift the transmission range lever to the neutral position if the engine stalls.
- 4.11. Never change the transmission range lever and depress the clutch pedal during mowing operation.

I. FOR SAFE OPERATION

4.12. Pay attention to other possible causes of danger which could lead to overturning, etc.

5. DRIVING ON PUBLIC ROADS:

5.1. This front mower cannot be driven on a public road without authorization by a local government agency. etc. Therefore it may be illegal for the front mower not only to travel on but also to cross a public road.

5.2. When transporting the front mower on a public road, load it on a truck.

6. LOADING ONTO OR UNLOADING FROM A TRUCK:

6.1. When loading the front mower onto a truck, turn off the truck's engine, apply the parking brakes to the truck, and chock the wheels to avoid unexpected moving of the truck.

6.2. Pay sufficient attention to safety conditions around the front mower and have it guided by someone to assist the operator. Never allow other persons to approach the front mower, especially in front of or behind it.

6.3. When loading the front mower onto a truck, lift up the mower deck fully and advance it straight at sufficiently low speeds. Drive it rearward when unloading it from the truck.

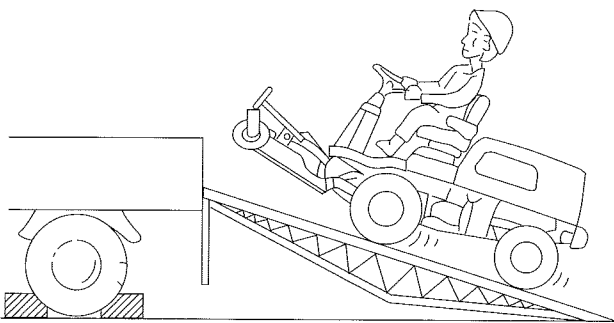

6.4. If the engine stalls unexpectedly on the ramps, depress the brake pedals immediately and roll the front mower to the ground by releasing the brakes gradually. Then start the engine and try again.

5.5. Use ramps with the same or better specifications mentioned below. When the front mower is equipped with the attachments other than those included in the specifications mentioned below, ask your dealers for advice.

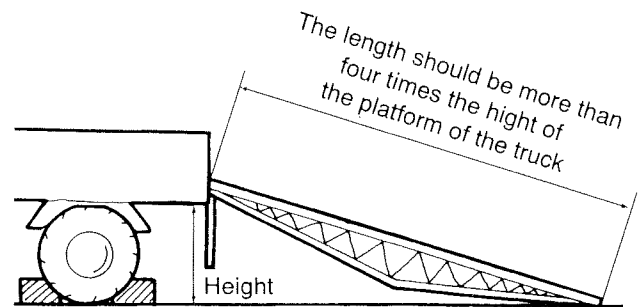

Specifications of the ramps for the SF333 and SF303

- Length more than 4 times the height of the platform of the truck
- Width (effective width) more than 30 cm
- Required quantity 2 ramps
- Capacity (one ramp) more than 750 kg
- Ramps should have anti-skid surfaces.

• The above specifications are effective with the front mower with the following configurations.

- Front mowers are not equipped with any attachments or a cabin.
- Front mowers are equipped with a standard mower deck.

6.6. Park the truck on hard level ground. Hook the ramps securely on the platform of the truck with the top of the ramp level with the platform.

6.7. Drive the front mower carefully at the moment the front mower moves from the ramps onto the platform, for it changes angles abruptly.

6.8. When the front mower is loaded on the truck, stop the engine, apply parking brakes, and withdraw the starter key, chock the wheels, and rope it securely to the truck. Refrain from unnecessary abrupt starting, stopping, and turning during transportation, or the front mower may shift position on the truck, which is very dangerous.

SF303 & SF333

7. WHEN FILLING WITH FUEL:

- 7.1. Never smoke while refilling with fuel, nor allow any open flames near the front mower.

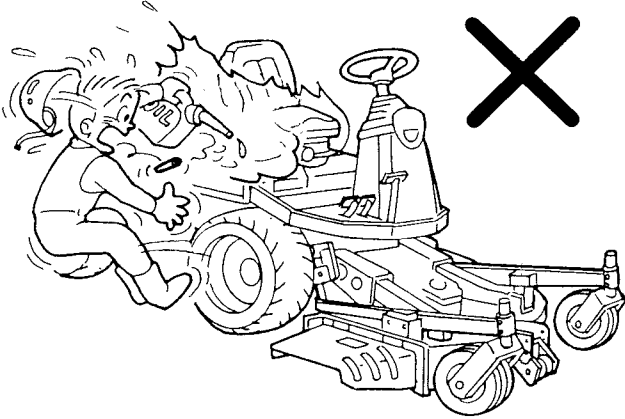

- 7.2. Never open the fuel tank cap while the engine is running or while it is still hot after operation. Wait until the engine cools down sufficiently.
- 7.3. Provide adequate measures to prevent fuel from spilling when pouring it into the fuel tank. Spilt fuel should be wiped off completely.
- 7.4. Avoid refueling indoors. If this is inevitable, provide sufficient ventilation.
- 7.5. Replace the fuel tank and container caps securely.
- 7.6. Store fuel in containers specifically designed for this purposes.

8. MOUNTING AND DISMOUNTING OF THE MOWER DRIVE SHAFT

The mower gear box is driven through a drive shaft with universal joints from the front mower. When connecting or disconnecting the shaft, follow the next instructions.

- 8.1. Lower the mower deck onto the ground, stop the engine, draw the engine key, and apply the parking brakes before mounting or dismantling the drive shaft.

- 8.2. Shift the PTO lever to the OFF position (☐).
- 8.3. Make sure that the PTO shaft and mower blades stop completely.
- 8.4. The drive shaft should be mounted or dismantled at the front mower side. Never leave the shaft connected only at the front mower side. If the PTO shaft be driven unexpectedly, the shaft will be swung around and damage the front mower or cause serious accidents.

9. FRONT MOWER MAINTENANCE:

- 9.1. Never start the engine in a closed place. Exhaust fumes contain poisonous carbon monoxide, so sufficient ventilation should be provided when starting the engine indoors.

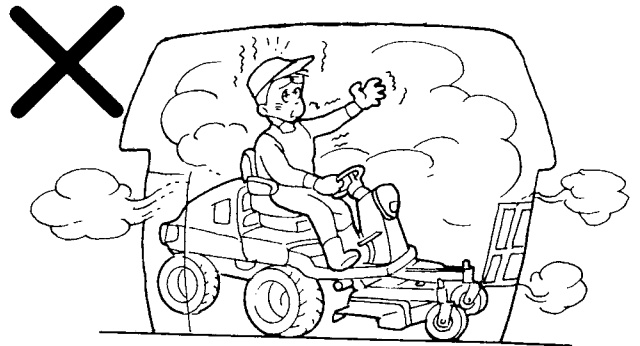

- 9.2. Be sure to wear safety glasses and gloves when servicing the front mower.
- 9.3. When servicing the front mower or mounting or dismantling the mower deck, place the front mower on level, hard ground.
- 9.4. Service the front mower in a place sufficiently illuminated, or darkness may cause unexpected accidents.

I. FOR SAFE OPERATION

- 9.5. When servicing the front mower or mounting or dismantling the mower deck, stop the engine and remove the engine key and apply the parking brakes.

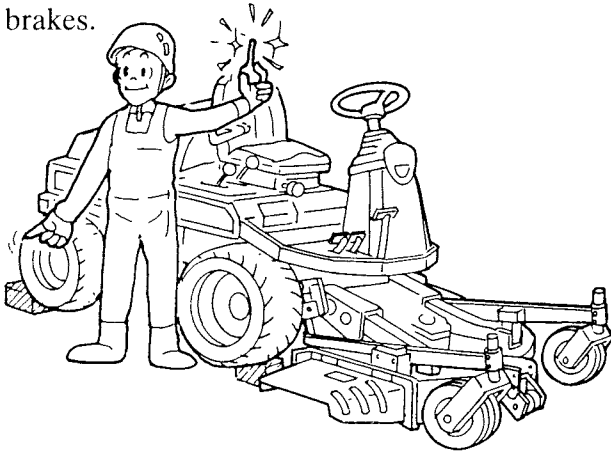

- 9.6. The engine, muffler, radiator, etc. are very hot just after operation, so wait until those heated parts cool down sufficiently to avoid burns.

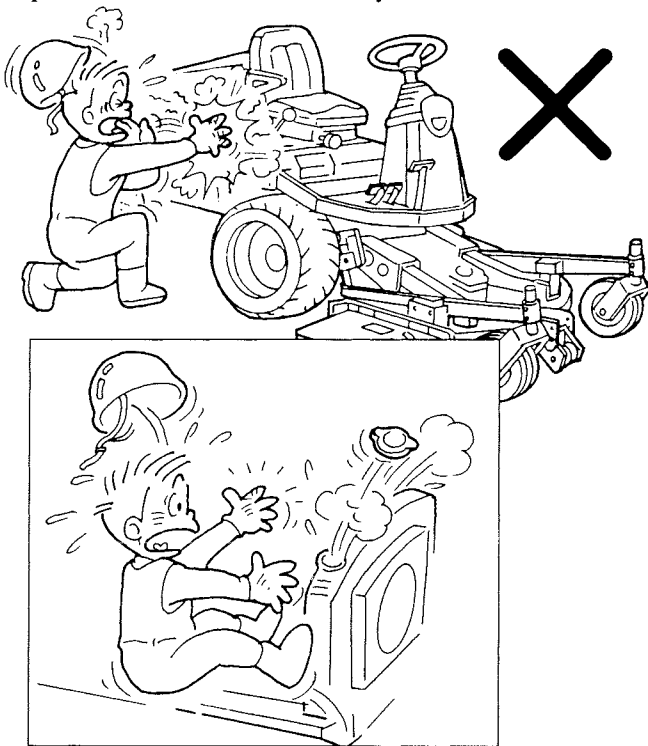

- 9.7. Never remove the radiator cap while the engine is hot or running. Wait until the engine cools down and then relieve the radiator pressure by releasing the radiator cap. Carelessly pouring cooling water into the heated radiator can cause serious damage to the radiator and the engine. Careless removal of the radiator cap can cause serious injury because of superheated water vapor.

- 9.8. Before servicing the front mower, be sure to shift the PTO lever to the OFF position and make sure that the mower blades have stopped completely. Rotating blades may cause serious accidents.

- 9.9. When servicing the front mower, use proper tools. Using makeshift tools may lead to injuries or poor service, which may result in unexpected accidents during operation.

- 9.10. When removing a tyre, chock other tyres and support the front mower securely. When installing tyres, be sure to tighten the wheel nuts to the specified torque. Loose nuts may cause serious accidents.

- 9.11. When raising up the mower deck for service, raise it up fully and apply the lift lock of hydraulic cylinder to avoid lowering.

- 9.12. When servicing the mower blades, pay sufficient care so your hands or fingers are not cut by them. As the three blades are driven by one belt, turning one blade will cause the other blades to turn.

- 9.13. Never step on the mower deck, or the mower deck may be damaged or deformed, which may lead to breakdown or accidents.

- 9.14. A first aid kit and a fire extinguisher should be kept in a place always in instant access.

- 9.15. Avoid high-pressure fluids. Escaping fluid under pressure can penetrate the skin and cause serious injury, so keep hands and body away from pin holes and nozzles ejecting such fluids. Be sure to consult your dealer about the hydraulic and fuel injection system troubles.

- 9.16. If any hydraulic fluid is injected accidentally into the skin, it must be removed within a few hours by a doctor familiar with this type of injury.

- 9.17. Never allow grass or leaves to accumulate around heated parts such as the engine and the muffler, or this may cause a fire.

SF303 & SF333

- 9.18. Be sure to reinstall the removed parts in place. Never attempt to start the engine with any parts removed.
- 9.19. Never attempt unauthorized modification of the front mower as this could be very hazardous. Damaged or worn parts should be replaced with ISEKI genuine spare parts. Unauthorized parts may cause breakdown of the front mower, accidents, and ISEKI warranty to expire.

	Parts code	Punched ID
SSM72	8654-306-006-0A	⊗8654C
SSM60	8655-306-003-0	⊗8655C

- 9.20. Keep all nuts, bolts and screws tight to be sure that the equipment is in safe working condition.

10. ELECTRICAL SYSTEM

- 10.1. Before servicing the electrical system, be sure to stop the engine, lower the mower deck on the ground, draw the starter key, shift the PTO lever to the OFF position, and apply parking brakes.
- 10.2. Before inspecting the connections of the electrical system, be sure to disconnect the negative terminal of the battery to avoid short circuits and electric shocks.

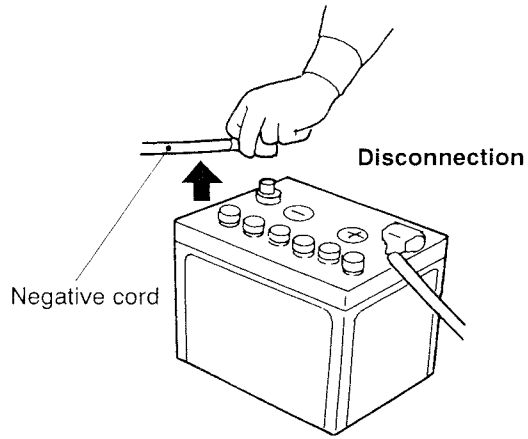

- 10.3. Loose connections, terminals, and damaged wiring should be repaired as soon as possible. They will not only deteriorate the performance of electric parts but also may cause short circuits, leading to fires.

- 10.4. The surroundings of the wiring and the battery should be kept clean, or accumulated grass or chaff may catch fire.
- 10.5. Never smoke nor allow any open flames nearby or sparks, which may be caused by short circuits during servicing the battery. The battery generates explosive gases (hydrogen and oxygen) during charging, so the battery should be charged in a place well ventilated to let such explosive gases diffuse smoothly. Otherwise settled gases may catch fire.

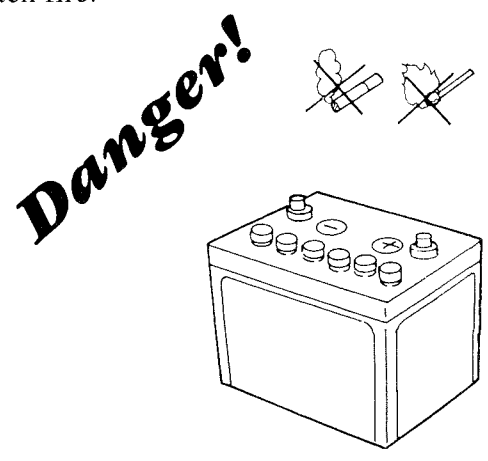

- 10.6. Battery electrolyte is diluted sulphuric acid, so it is corrosive and naturally poisonous. Never allow acid to contact skin or clothing, or it may cause burns. Always wear a face shield to avoid acid getting in eyes. If acid contacts skin or clothing, wash off immediately with clean water. If acid contacts eyes, flush immediately with clean water and get medical attention.
- 10.7. Before servicing and mounting or dismantling the battery, stop the engine, draw the starter key, and apply the parking brakes. Otherwise, electric parts may be damaged.
- 10.8. When disconnecting the battery, disconnect the negative (-) cable first, while connect the positive (+) cable first when connecting the battery. Wrong order of disconnecting or connecting the battery will cause sparks, which is very dangerous.

I. FOR SAFE OPERATION

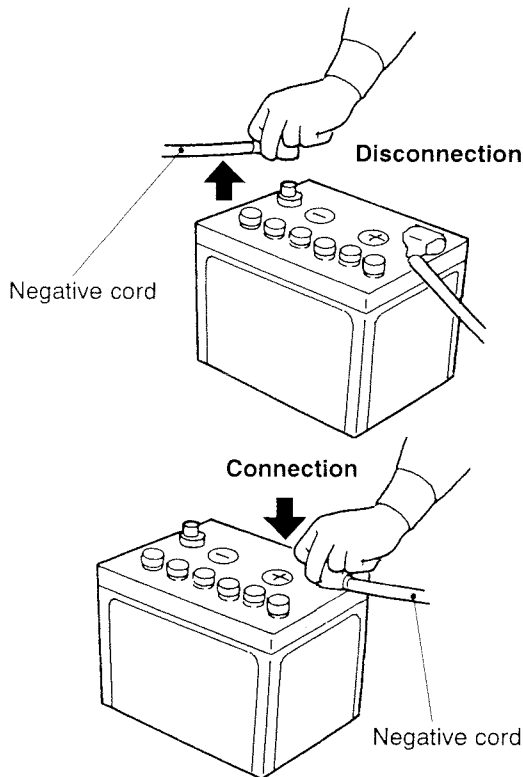

10.9. When using booster cables, observe the following instructions to avoid accidents:

- Remove the filler caps of battery cells ahead of time to lessen explosive power of gases if they should catch fire.
- Before connecting booster cables, be sure to stop the engine.
- Use booster cables of sufficient capacity, or they may be heated or burnt out.

11. TYRES AND WHEELS

11.1. Be sure to keep tyre pressures at the levels specified in this manual. Excessively high tyre pressure may result in explosion, which may lead to physical accidents.

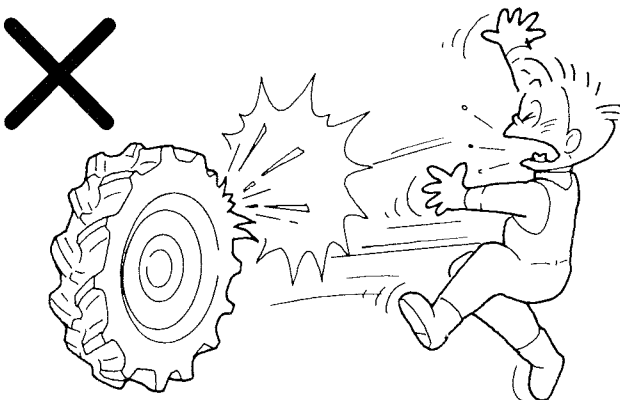

11.2. If a cut is found in a tyre and the cut reaches the cords, do not use it. Such a tyre may explode.

11.3. Before replacing or repairing tyres, tubes, or rims, consult your dealers ahead of time. Such operation should be performed by trained mechanics.

12. BEFORE STORING THE FRONT MOWER

12.1. After operation, be sure to close the fuel cock to prevent fuel from spilling, as spilled fuel may catch fire.

12.2. Never allow grass or leaves to accumulate around heated parts such as the engine and the muffler, or this may cause a fire.

12.3. Be sure to remove the ignition key to prevent unexpected accidents caused by engine starting by untrained persons or children.

12.4. When storing the front mower with the mower deck attached, be sure to lower the mower deck on the ground. Otherwise manipulation of the lift lever by untrained person or children may cause unexpected accidents.

12.5. Store the front mower in a place provided with sufficient illumination. Inspection and moving of the front mower in a dark place may lead to unexpected accidents.

12.6. When the front mower is to be stored in a closed place like a garage or a barn, provide sufficient ventilation for exhaust gases. Exhaust fumes can be lethal.

12.7. To avoid fire hazard, keep the engine, muffler, battery, and fuel storage area free of grass, leaves, or excessive grease.

12.8. Never cover a hot front mower just after operation with a tarpaulin or the like, or the heated engine and related parts may cause a fire.

SF303 & SF333

(2) Battery label

(Code No. 1705-904-002-0)

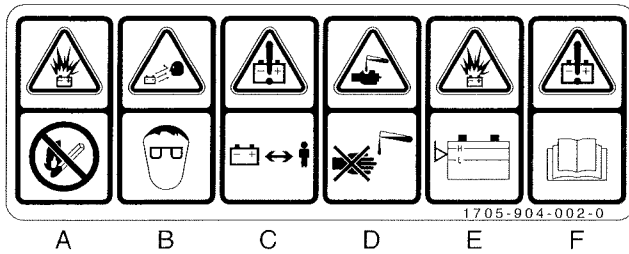

A. WARNING: RISK OF EXPLOSION

Keep away from sparks or flames, which could cause explosion.

B. WARNING: WEAR AN EYE PROTECTION DEVICE

Battery electrolyte (sulphuric acid) may cause blindness. Wear an eye protector to prevent contact with the eyes.

C. WARNING: KEEP OUT OF REACH OF CHILDREN

D. WARNING: RISK OF BURNS

Battery electrolyte (sulphuric acid) may cause burns. Avoid contact with skin or clothing. In case of an accident, flush affected part immediately with plenty of water.

E. WARNING: RISK OF EXPLOSION

Never use the battery with the electrolyte surface below the "LOWER" limit, or it may explode. Never replenish exceeding "UPPER" limit or electrolyte may leak out.

F. WARNING: READ OPERATION MANUAL

Read the safety and operating instructions in the operation manual before operating the tractor.

Take care of handling the battery.

Improper handling may lead to explosion.

Never short the poles.

Charge the battery in well ventilated place.

(3) Fuel label

(Code No. 1705-904-001-0)

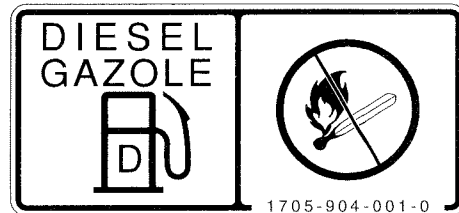

DANGER: RISK OF EXPLOSION AND BURNS

Use only diesel fuel.

Before replenishing fuel, be sure to stop the engine and wait until the engine and heated parts cool down sufficiently. Keep sparks, open flames, etc. away from the fuel tank. No smoking!

(4) Hot-part warning label

(Code No. 8595-901-007-0)

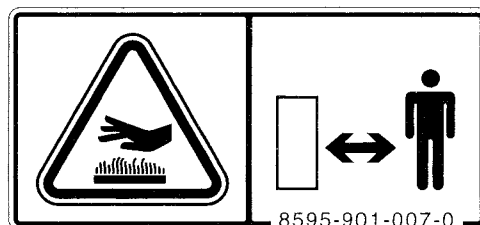

WARNING: HOT SURFACES, RISK OF BURNS ON HANDS AND FINGERS

Stay clear of the heated parts until they cool down sufficiently.

(5) Fan warning label

(Code No. 1705-902-006-0)



WARNING: RISK OF ENTANGLEMENT

Stay clear of the fan while it is turning.

I. FOR SAFE OPERATION

(6) Belt warning label

(Code No. 8595-901-006-0)

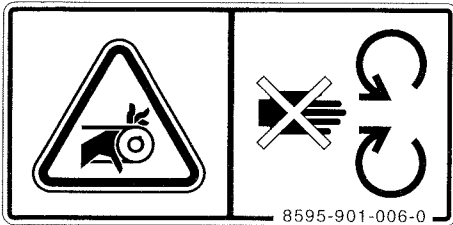

WARNING: RISK OF ENTANGLEMENT
Stay clear of the belt while it is running.

(9) Lift lock label

(Code No. 1720-906-001-0A)

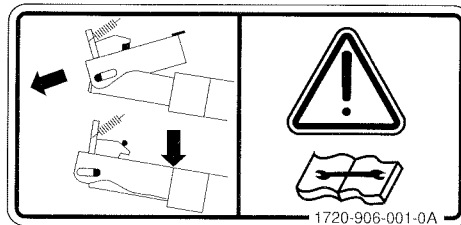

WARNING: When raising up the mower deck for service, apply the lift lock of hydraulic cylinder.

(7) Starter warning label

(Code No. 1705-902-007-0)

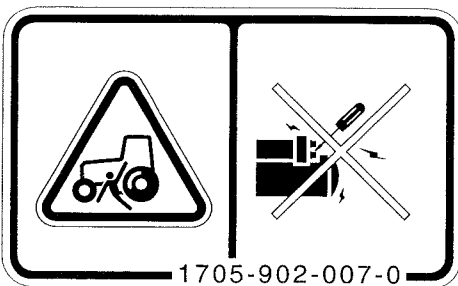

DANGER: RISK OF ELECTRIC SHOCK
Start the engine only from the seat using the key.

(10) Brake warning label

(Code No. 1636-901-021-0)

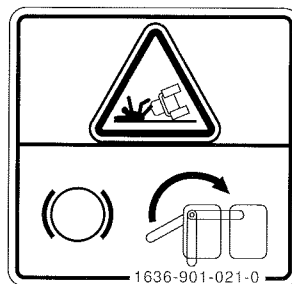

WARNING: Do not use individual wheel brakes for transporting or operating at high speed. Always latch pedals together using interlocking.

(8) Radiator warning label

(Code No. 1705-902-008-0)

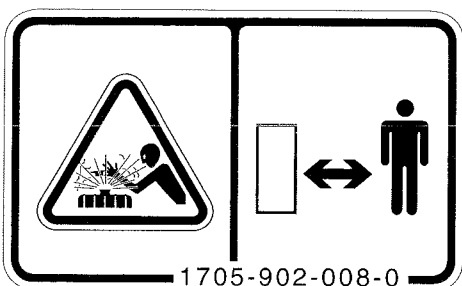

WARNING: HIGH PRESSURE STEAM AND HOT WATER

Never remove the radiator cap during or just after operation. The water in the radiator is very hot and highly pressurized, which could cause burns.

SF303 & SF333

(11) Brake label

(Code No. 1720-906-002-0A)

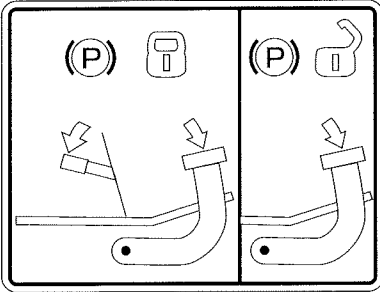

To engage parking brake, depress master brake pedal fully. While brake is depressed, move parking lever lower to applied position.

To disengage parking brake, firmly depress master brake pedal.

To locking mechanism will be released automatically.

(12) Tilt control label

(Code No. 1636-901-018-0)

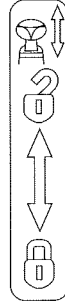

While holding steering wheel with both hands, raise tilt locking lever and select desired position.

Release lever and make sure steering wheel is securely locked by lever returning to original position.

I. FOR SAFE OPERATION

• Positions of the caution labels

- (1) Caution label
- (2) Battery label
- (3) Fuel label
- (4) Hot part warning label
- (5) Fan warning label
- (6) Belt warning label
- (7) Starter warning label
- (8) Radiator warning label
- (9) Lift lock label
- (10) Brake warning label
- (11) Brake label
- (12) Tilt control label

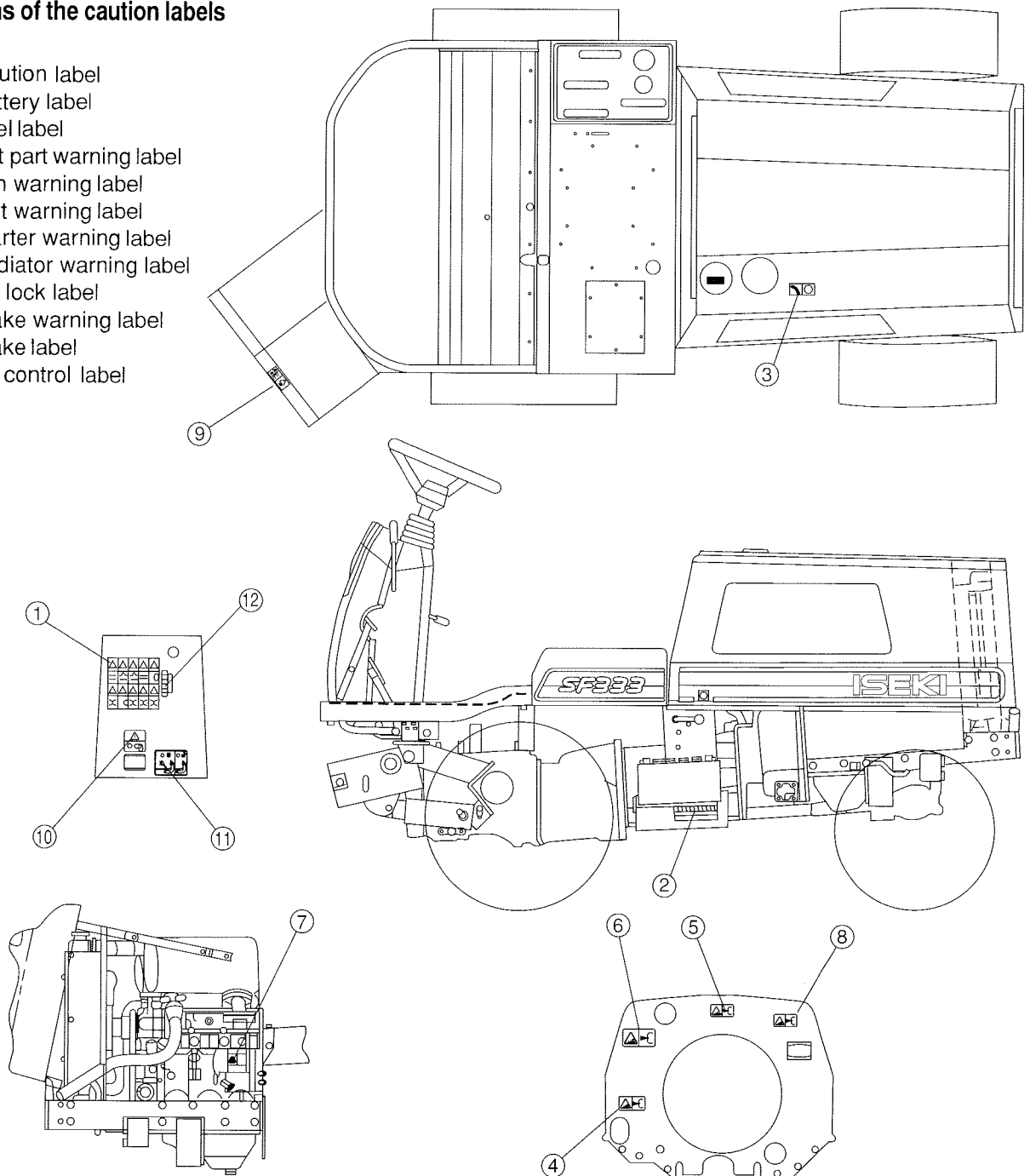

• Maintenance of the caution labels

- The labels should always be clearly seen, that is, nothing should obscure them.
- When they have become dirty, wash them with soap water and wipe off with soft cloth.
- If any of them are torn or lost, order new labels from your dealer.
- A new label should be placed in the same place where the old one was located.
- When sticking on a new label, clean the place to enable the label to stick and squeeze out all air bubbles trapped under it.

SF303 & SF333

• LOCATIONS OF THE MODEL NAME AND SERIAL NUMBER

When asking your dealers to adjust or repair your machine, please give them the following numbers which identify your machine, which will lead to proper and quick service.

- a. Tractor model name: SF303 or SF333
- b. Tractor serial number: No. _____
- c. Engine serial number: No. _____
- d. Mower model name: SSM60 or SSM72
- e. Mower serial number: No. _____

Fill the underlined parts with the respective numbers of your machine.

The tractor model name and serial number are found on the back of the steering column cover.

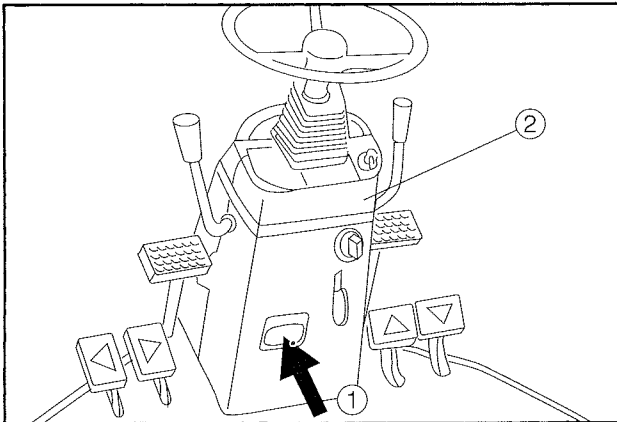

- (1) Tractor model name and serial number
- (2) Steering column cover

The serial number of the engine is punched under the engine model name on the left side of the cylinder block.

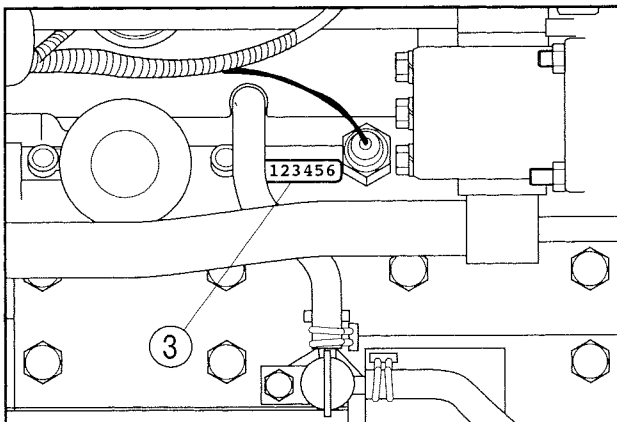

- (3) Engine serial number

The model name and serial number of the mower are found on the left rear of the mower deck.

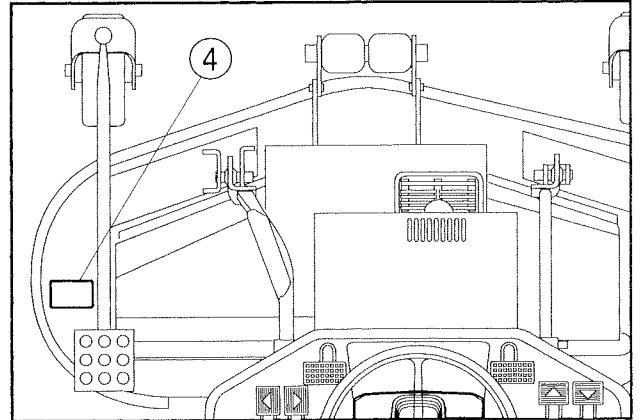

- (4) Mower model name and serial number

II. SPECIFICATIONS

TRACTORS

Model			SF303	SF333	
Dimensions	Overall length	UWE/UXWE	2320 mm (91.3 in.)		
		UXE	2195 mm (86.4 in.)		
(with balance weights)	Overall width		1200 mm (47.2 in.)		
	Overall height		1430 mm (56.3 in.)		
Weight			UWE 833kg	1836 lb.	
			UXE 761kg	1678 lb.	
			UXWE 841kg	1854 lb.	
Engine	Model		E3CE-G	E3CD-G	
	Type		Vertical, water-cooled, 4-cycle, diesel		
	Combustion chamber		Swirl chamber type		
	No. of cylinders		3		
	Total displacement		1429 cc (87 cu. in.)	1498 cc (91 cu.in.)	
	Maximum output (gross)		28 ps (20.5 kW)/2500 rpm	31 ps (22.8 kW)/2500 rpm	
Fuel	Diesel fuel				
Fuel tank capacity	40 liters (8.8 Imp. gal.)				
Transmission	Main transmission		HST (Hydrostatic transmission)		
	Transmission range		Manual shift, 2 stages		
	Travel speeds	Forward	High	0 – 17.6 km/h (0 – 10.9 mph)	
			Low	0 – 9.3 km/h (0 – 5.8 mph)	
	Reverse	High	0 – 9.1 km/h (0 – 5.7 mph)		
Low		0 – 4.8 km/h (0 – 3.0 mph)			
Wheel base	1250 mm (49.2 in.)				
Wheel tread	Front	950 mm (37.4 in.)			
	Rear	960 mm (37.8 in.)			
Driving system	UWE		2/4WD manual shift		
	UXE/UXWE		2/4WD automatic shift-manual shift (4WD)		
Steering system	Mechanism		Power-assisted		
	Steered wheels		Rear wheels		
Brake system	Wet, multi-disk				
Tyre size	Front	23 x 10.5 – 12 4P			
	Rear	20 x 8.0 – 10 4P			
PTO	Front	High	2100 rpm		
		Low	1050 rpm		
PTO clutch	Dry, single disc common with main clutch				
Minimum ground clearance	170 mm (6.7 in.)				

MOWERS

Model			SSM 60	SSM 72
Type	Rotary mower			
Cutting width			1524 mm (60 in.)	1830 mm (72 in.)
No. of blades	3			
Dimensions	Overall length		1073 mm (42.2 in.)	1165 mm (45.9 in.)
	Overall width		1900 mm (74.8 in.)	2280 mm (89.8 in.)
	Overall height		524 mm (20.2 in.)	521 mm (20.5 in.)
Weight			200 kg (441 lbs)	230 kg (507 lbs)
Cutting-height adjustment	Adjustable in 6 stages by pin replacement			
Cutting heights	30 – 120 mm (1.2 – 4.7 in.)			

III. NAMES OF MAJOR COMPONENTS

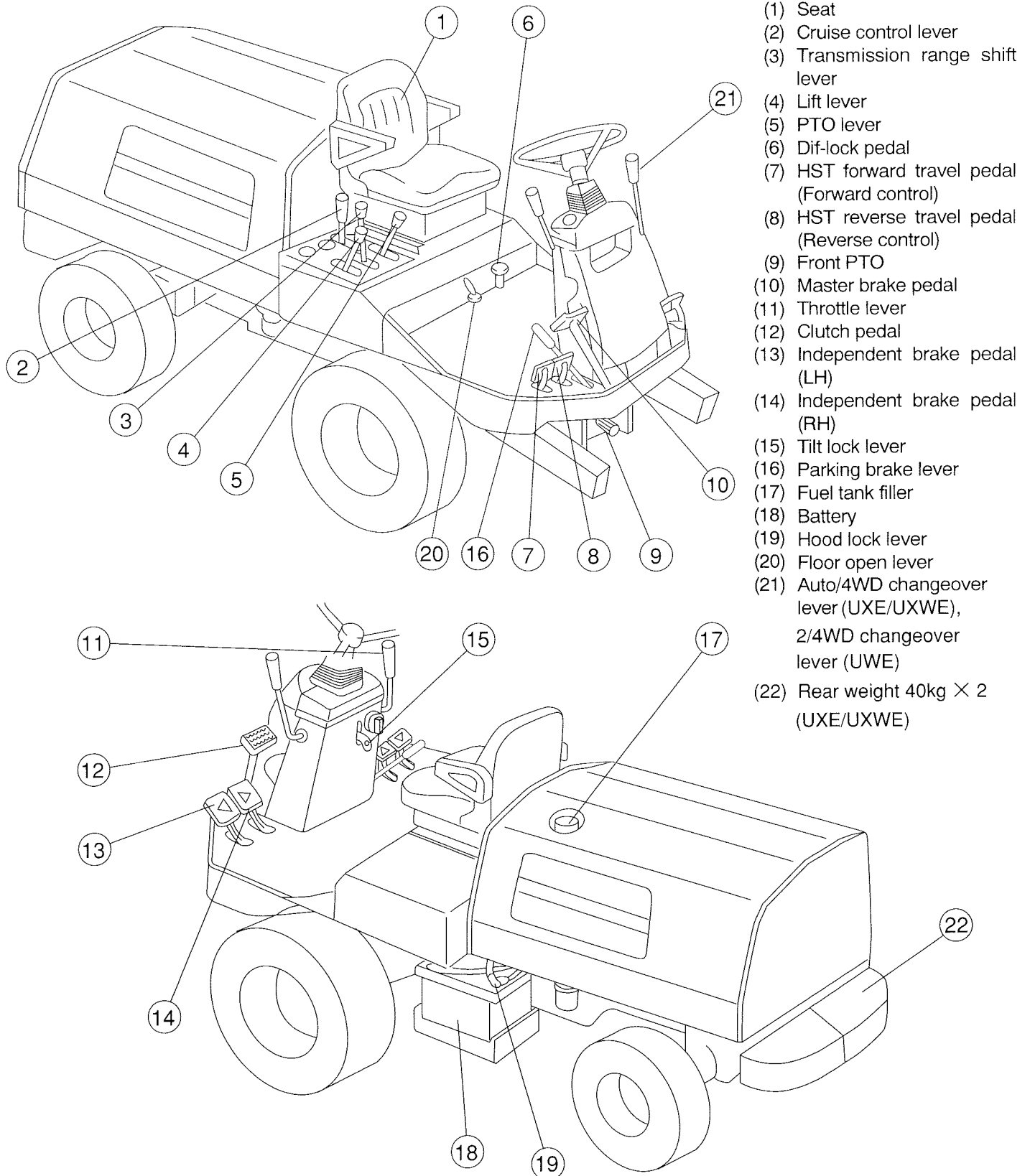

IV. CONTROLS AND METERS

1. CONTROL PANEL

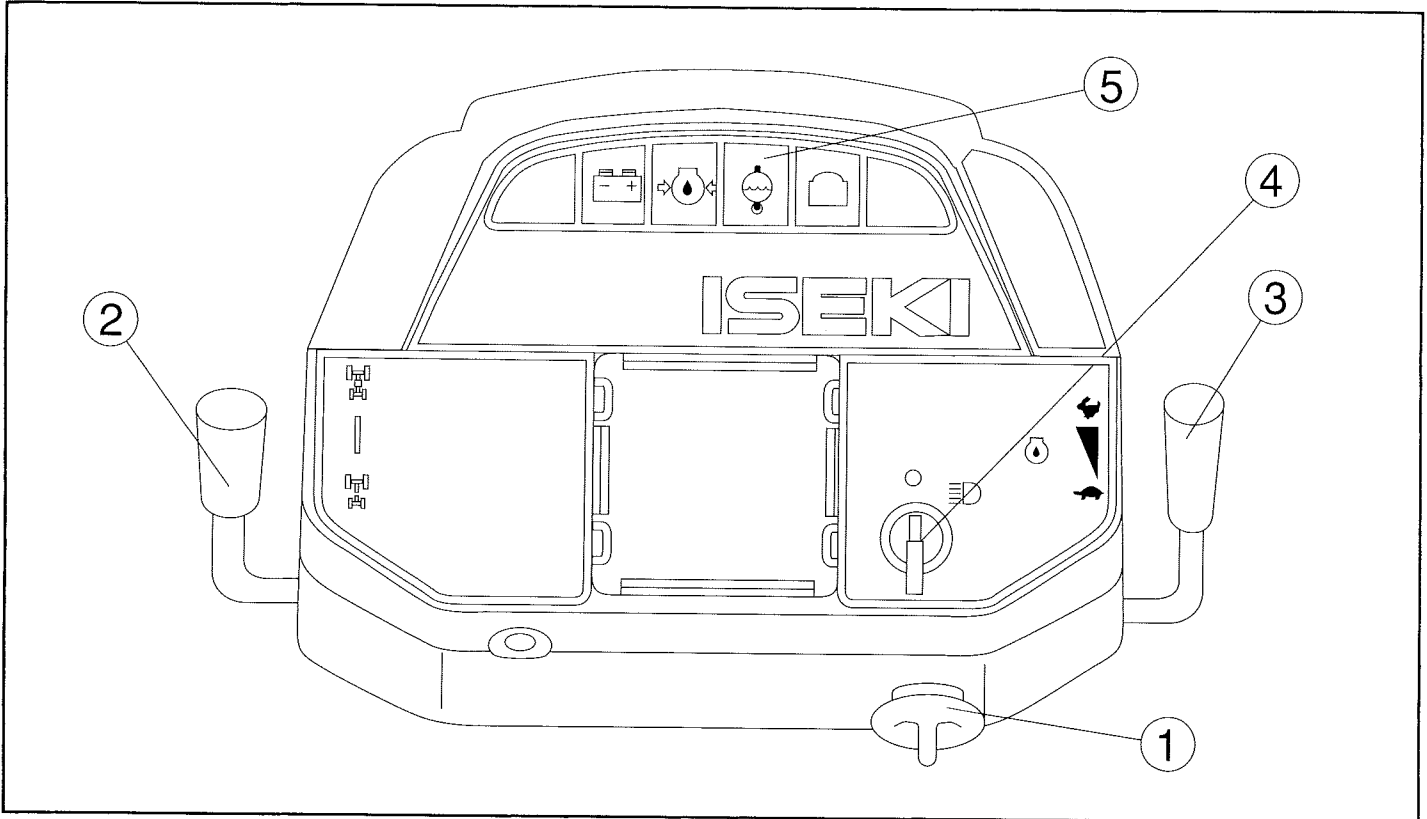



- | | |
|---|------------------------|
| (1) Starter switch | (4) Head lamp switch |
| (2) Auto/4WD changeover lever (UXE)
2/4WD changeover lever (UWE) | (5) Monitor lamp array |
| (3) Throttle lever | |

1.1. STARTER SWITCH

The engine starts only when you are seated in the operator's seat, depress the clutch pedal completely, and shift the PTO lever to the neutral position.

The engine is equipped with a pre-heating system. Be sure to preheat the engine before starting.

 : Glow position : the engine is pre-heated in this position.

 : OFF position: the engine stops and all electric circuits are turned off.

 : ON position: the key turns to this position after starting the engine and remains there during operation.

 : START position: the starter motor is switched on in this position.

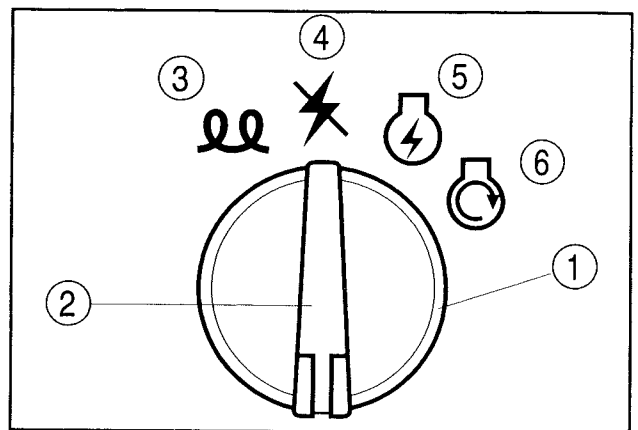

- | | |
|------------------------|--------------------|
| (1) Starter switch | (4) OFF position |
| (2) Starter switch key | (5) ON position |
| (3) Glow position | (6) START position |

SF303 & SF333

1.2. GLOW

When the starter key is turned to the glow position, the engine is preheated.

When the engine has started, release the key at once.

Important:

If the glow operation continues more than 20 seconds, the glow plugs may burn out. When the engine fails to start, wait more than 20 seconds at least before the next attempt.

1.3. THROTTLE LEVER

With this lever, the engine speed is controlled.

 : Turn this lever towards the “turtle” mark, the engine decelerates.

 : Turn this lever towards the “rabbit” mark, the engine accelerates.

1.4. HEAD LAMP SWITCH

This switch turns the headlamps on and off.

 : Turn the switch lever towards this mark, and the headlamps turn on and vice versa.

1.5. MONITOR LAMP ARRAY

• **Charge lamp:**

 : The lamp lights up while the battery is not being charged. It also lights up when the key turns to the ON position or the START position while the engine stops, but turns off as soon as the engine starts.

• **Oil pressure lamp:**

 : The lamp lights up when the engine oil pressure is not circulating normally. It also lights up when the key turns to the ON position or the START position while the engine stops, but turns off as soon as the engine starts.

• **Engine coolant warning lamp:**

 : The lamp lights up when the engine coolant is over-heated.

When the engine coolant is over-heated, the monitor lamp is lit and at the same time the buzzer sounds while the PTO lever is in the “ON” position. The buzzer turns off when the PTO lever is shifted to the “OFF” position.

When the monitor lamp is lit, shift the PTO lever to the “OFF” position, decelerated the engine to idling, and wait until the lamp turns off.

When the lamp turns off, stop the engine and correct the trouble (clogged grass or dust around engine, radiator, etc.). Then re-start operation.



Warning:

When inspecting the radiator, be sure that the engine cools down sufficiently. Never release the radiator cap while the coolant is hot, or boiling water will gush out.



Caution:

Remove the starter key from the switch when the machine is not in use to avoid other people manipulating the machine.

2. FENDER (WING) PANEL

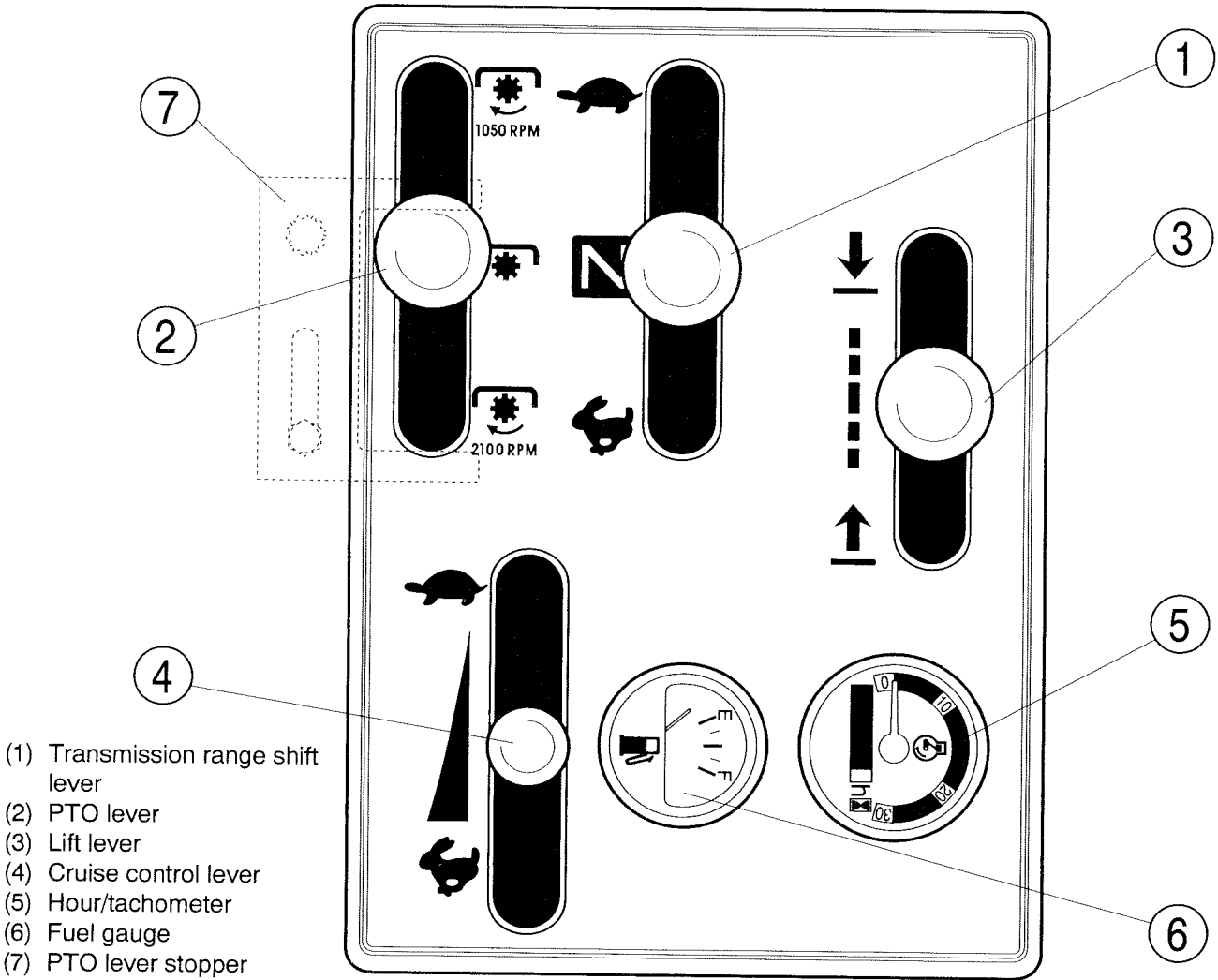

2.1. TRANSMISSION RANGE SHIFT LEVER

This lever shifts the transmission range into “HIGH” and “LOW” speed ranges.

 : Push the lever to “LOW”, and the transmission is shifted to the low speed range.

 : Push the lever to “HIGH”, and the transmission is shifted to the high speed range.

 : At “NEUTRAL”, the transmission is at the neutral position.

Before shifting the transmission range, be sure to disengage the clutch by depressing the pedal to stop the tractor from travelling.

2.2. PTO LEVER

This lever shifts the PTO speed into two stages.

 : Shift the lever to the position indicated by this mark, and the front PTO shaft starts spinning.

 : Shift the lever to the position indicated by this mark, and the front PTO shaft stops spinning.

Mower operation does not require the 1050-rpm PTO speed, so this position is blocked with the lever stopper to restrict the lever operation for safety. At this position, the mower would not operate properly.

SF303 & SF333

When the 1050-rpm PTO speed is required for other operations, remove the lever stopper, and the PTO can be shifted to that speed.

Note:

When the 1050-rpm PTO speed is required, consult your dealers beforehand.

2.3. LIFT LEVER

With this lever, the lift is raised or lowered.



: Shift the lever to this mark, the lift is lowered.



: Shift the lever to this mark, the lift is raised.



Caution:

- When servicing the tractor-mounted mower, be sure to stop the engine and remove the starter key.
- As the lift cylinder is equipped with a lift locking device, be sure to raise the lift to its uppermost position and engage the lift lock when servicing the tractor-mounted mower.
- Do not hold the lift lever too long in the “UP” position, or it may damage the hydraulic system.

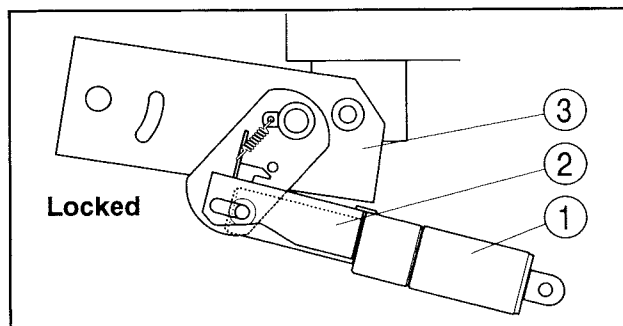
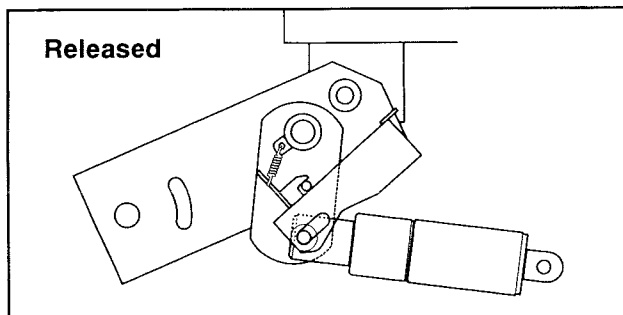

- (1) Hydraulic cylinder (3) Lift link
(2) Lift lock

2.4. CRUISE CONTROL LEVER

When this lever is shifted in the required position, the cruising speed is held there without operating the HST forward travel pedal.

Step-less speed shift is possible within the range between the “HIGH” speed mark (☛) and the “LOW” speed mark (☜).

When a required speed is attained with the HST forward travel pedal, move the lever from ☜ to ☛ until the movement feels heavy and release the HST pedal, and then the attained travel speed is held.

The cruise control is released by depressing the master brake pedal or shift the lever to the “LOW” speed position (☜).

With this lever, reverse travel speed is not controlled.

Important:

- When slowing down during cruise travel, shift the lever towards the “LOW” speed position, and then the control is released and the travel speed is controllable with the lever or the HST forward travel pedal. When speeding up during cruise travel, shift the lever towards the “HIGH” speed position (☛) or depress the HST forward travel pedal.
- The cruise control should be set only while the transmission range is engaged in the “LOW” position (☜). The cruise control set at high speed range is very dangerous.

2.5. HOUR/TACHOMETER

The hourmeter counts operation hours of the tractor and show them in 5-digit number. The least significant figure shows one tenth hour of operation.

The tachometer shows current running speed of the engine by one hundredth of engine speed (× 100).

2.6. FUEL GAUGE

The gauge shows the fuel level.

3. CONTROL PEDALS AND LEVERS

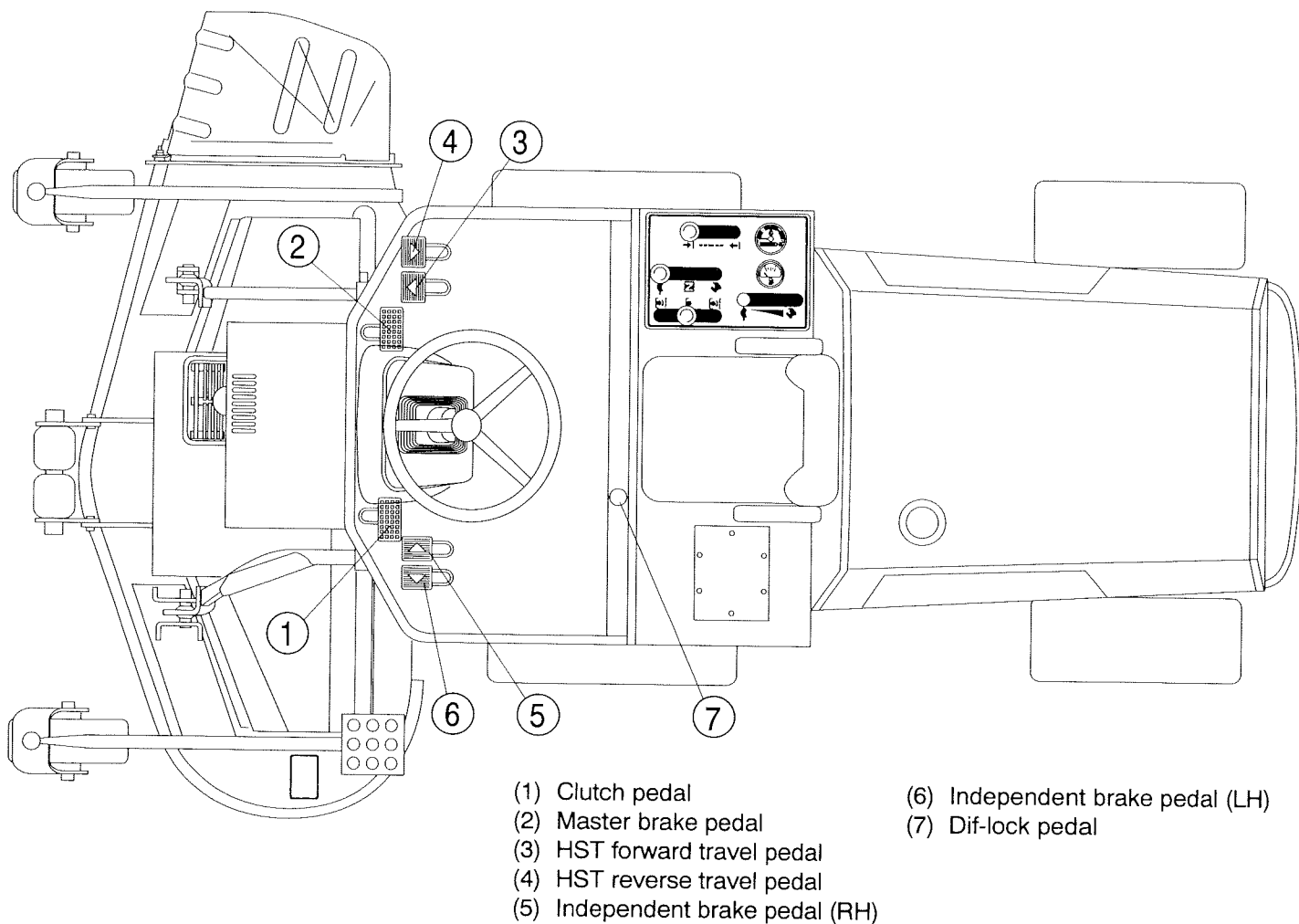

- (1) Clutch pedal
- (2) Master brake pedal
- (3) HST forward travel pedal
- (4) HST reverse travel pedal
- (5) Independent brake pedal (RH)
- (6) Independent brake pedal (LH)
- (7) Dif-lock pedal

3.1. CLUTCH PEDAL

With this pedal, the clutch is engaged or disengaged, that is, the engine power is applied or not applied to the transmission.

Important:

- *Depress the pedal quickly and release it slowly.*
- *Never rest your foot on the pedal during operation, or the clutch disk is worn quickly.*
- *The clutch pedal can be held cut off by engaging the cut-off arm. It should be held disengaged for long time storage.*
- *To engage the cut-off arm, depress the clutch pedal to the end and engage the cut-off arm on the pin of the clutch pedal.*

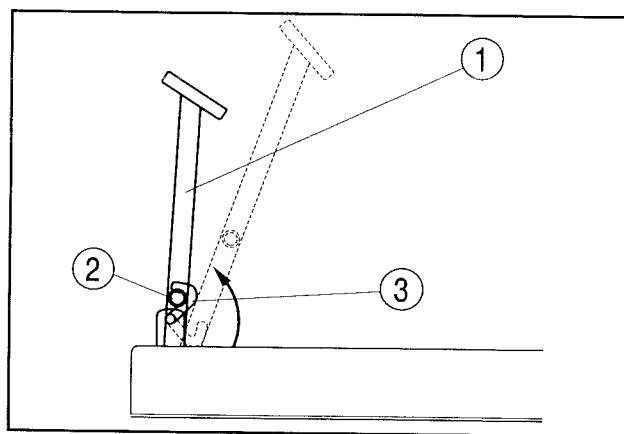

(1) Clutch pedal (2) Pin (3) Cut-off arm

3.2. MASTER BRAKE PEDAL

The front mower stops travelling by depressing this pedal, which engage the right and left brakes at the same time.

SF303 & SF333

3.3. HST FORWARD TRAVEL PEDAL

Depress this pedal, and the front mower starts moving forward. Forward travelling speed is controlled only by depressing it: forward travel accelerates and decelerates by the extent the pedal is depressed.

3.4. HST REVERSE TRAVEL PEDAL

Depress this pedal, and the front mower starts reversing. Reverse travelling speed is controlled only by depressing it: reverse travel accelerates and decelerates by the extent the pedal is depressed.

3.5. INDEPENDENT BRAKE PEDAL (RH)

This pedal affects the right-hand front wheel alone.

3.6. INDEPENDENT BRAKE PEDAL (LH)

This pedal affects the left-hand front wheel alone.



Warning:

- *Never operate the independent brake pedal during travelling as this will cause the front mower to skid sideways or turn over. When stopping, be sure to use the master brake pedal.*

Cautions:

- *Use of the independent brake may damage the turf, so never use it during operation on turfs.*
- *When making a quick turn within a garage or a barn, do this at sufficiently slow speed.*

3.7. DIF-LOCK PEDAL

To minimize the turning radius of the tractor, the differential is installed, which causes the right and left driving wheels to turn at different speed when turning. On the other hand, it causes the wheels to slip on wet grass or soft ground. In such a case, lower engine speed and depress the dif-lock pedal, and then the differential is locked and both wheels turn at the same speed, which results in straighter travelling.



Warning:

- *It is very dangerous to attempt to turn the front mower with the dif-lock pedal depressed. When turning the tractor, be sure to release the dif-lock pedal.*

Important:

- *When the dif-lock is not released despite releasing the dif-lock pedal, depress the right and left independent brake pedals lightly and alternatively.*

4. PARKING BRAKE LEVER AND TILT LOCK LEVER

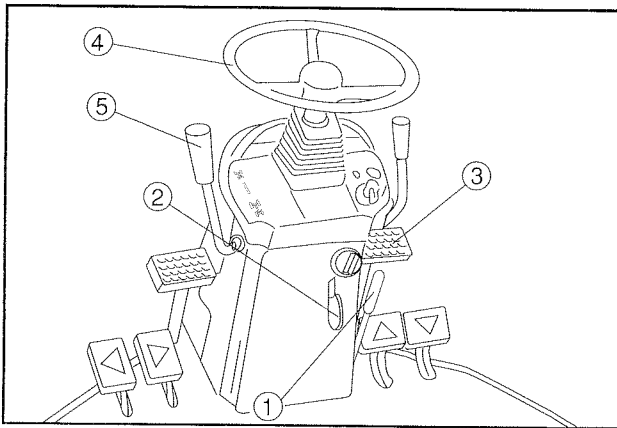

- (1) Parking brake lever
- (2) Tilt lock lever
- (3) Master brake pedal
- (4) Steering wheel
- (5) Auto/4WD changeover lever (UXE)
2/4WD changeover lever (UWE)

4.1. PARKING BRAKE LEVER

While depressing the master brake pedal fully, push down the lever and the parking brake is applied. To release the parking brake, depress the master brake pedal again.

Important:

Never start travelling with the parking brake applied, or the brake performance will deteriorate soon or, even worse, the brake system could break down.

Caution:

When leaving the front mower, be sure to apply the parking brake.

4.2. TILT LOCK LEVER

The steering wheel *column* is tiltable to gain the optimum wheel angles. To adjust the angles, pull up the tilt lock lever while holding the steering wheel with the other hand, and the lock is released. Select the most adequate angle within the four setting position. Then push down the lever securely to lock the steering wheel column.

Caution:

- *Only adjust steering tilt when the machine is parked.*

5. BONNET OPEN/CLOSE LEVER

The lever is located in the centre of the left-hand side of the tractor. The bonnet is locked and unlocked by turning this lever.

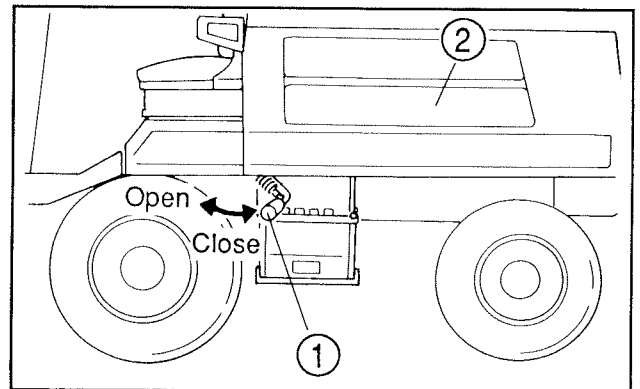

- (1) Open/close lever
- (2) Bonnet

6. SAFETY SWITCHES

The operator's seat, clutch pedal, and PTO lever are equipped with a safety switch respectively. Before starting the engine, the operator should be seated in the operator's seat, depress the clutch pedal fully, and shift the PTO lever to the neutral position.

When the operator has to leave the front mower with the engine running for warming up or to observe the functioning of various parts, hold the clutch should be held disengaged by hooking the cut-off arm on the clutch pedal.

Caution:

When the engine is difficult to start or to stop due to a defective safety switch, consult your dealer at once.

SF303 & SF333

7. WHEEL DRIVING MODE MANUALLY CHANGE-OVER LEVER

The lever is located on the left side of the steering column post. With this lever, 2WD/4WD automatic change-over and permanent 4WD is selectable. (UXE/UXWE)

With this lever, permanent 2WD and 4WD is selectable. (UWE)

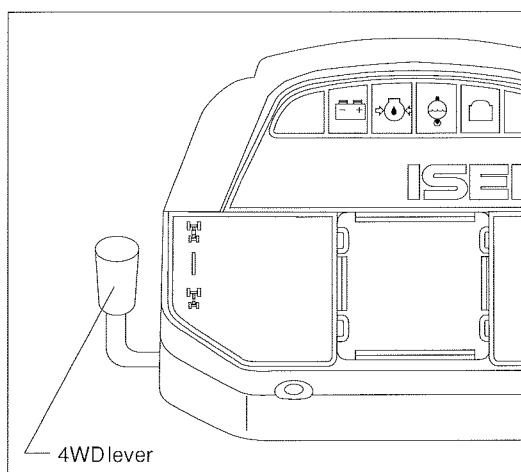

Model	Lever position	Lever position	Working place
UWE	4WD	Push forward	on slope
	2WD	Pull rearward	on level ground
UXE UXWE	4WD	Push forward	on slope
	2/4WD automatically	Pull rearward	on level ground

- (1) Auto/4WD changeover lever
- 2/4WD changeover lever

2-wheel drive and 4-wheel drive is selected automatically during operation on a level ground, so the lever operation is not required. (UXE/UXWE)

When operating on a slope, shift the changeover lever to the 4WD position without fail.

Caution:

Be sure to shift the changeover lever to the "AUTO" or "2WD" position when operating on level ground, as level ground operation with the 4WD selected leads to a larger turning radius and may cause turf damage.

When shifting the changeover lever, slow down the traveling speed below 1km/h and make the machine go straight.

Warning:

When operating the tractor on a slope, be sure the changeover lever is locked in the 4WD position from the reasons mentioned below:

In the AUTO position, the mechanism shifts to 2WD automatically when the peripheral speed of the front wheels exceeds that of the rear wheels, which means loss of rear wheel driving power. (UXE/UXWE)

For example, when moving uphill if the front wheels slip, the mechanism stays in 4WD. But moving downhill hill if the front wheels slip and lose grip, and begin to slip down the slope, it shifts to 2WD, that is, braking effect of the HST unit is lost, which means loss of tractor control.

From another point of view, when you try to turn the tractor on a slope, rear wheel driving power is lost and the tractor may slip down the slope, which is also very dangerous. (UXE/UXWE)

8. EXTERNAL HYDRAULIC CONTROL LEVERS (SF330-V)

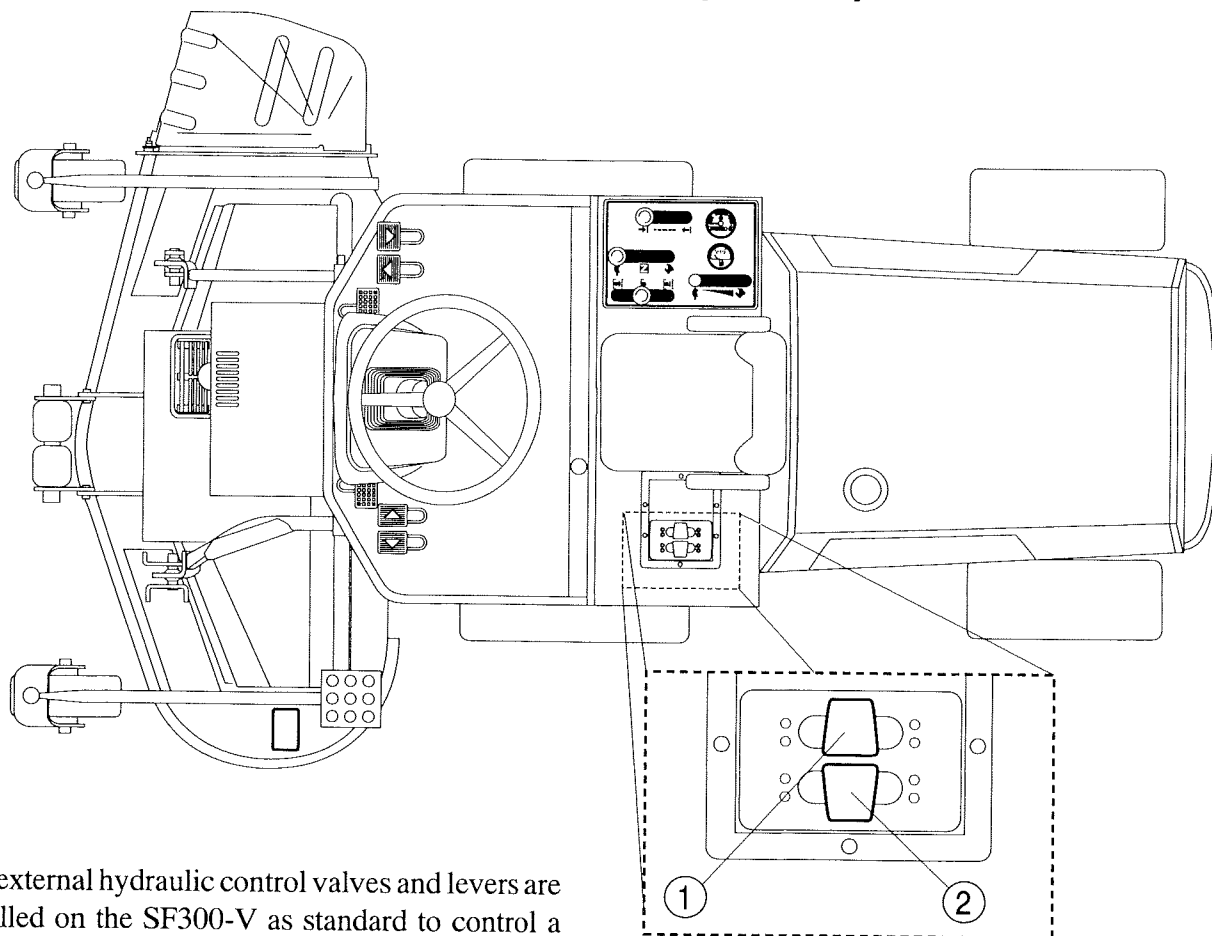

External hydraulic control levers

The external hydraulic control valves and levers are installed on the SF330-V as standard to control a hydraulically-operated implement other than the mower deck. Consequently the lever operation is different with each implement.

- Tilt the inside lever (1) rearward, and then highly pressurized fluid is delivered through port A1.
- Tilt the inside lever (1) forward, and then highly pressurized fluid is delivered through port B1.
- Tilt the outside lever (2) rearward, and then highly pressurized fluid is delivered through port A2.
- Tilt the outside lever (2) forward, and then highly pressurized fluid is delivered through port B2.



Caution:

Be sure to consult your ISEKI dealers on implement installation, hydraulic piping, installation of auxiliary frames, etc.

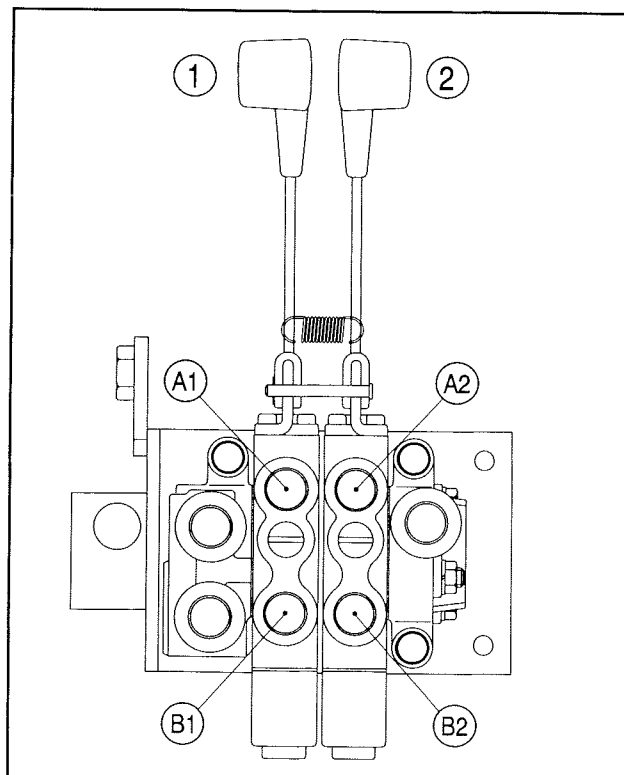

V. OPERATION

1. BEFORE STARTING THE ENGINE



Warning:

- Before starting the engine, be sure to carry out the pre-operation inspection in accordance with the periodical inspection table on page 47.
- Follow instructions given in "I. FOR SAFETY OPERATION."
- Observe instructions given on the caution labels on the machine.

2. STARTING THE ENGINE



Caution:

- Never attempt to start the engine in an enclosed place with poor ventilation. Be sure to provide sufficient ventilation, for exhaust fumes can be lethal.

Before starting the engine, sit down in the operator's seat properly, depress the clutch pedal fully, and shift the PTO lever to the neutral position (☞), or the engine cannot be started.

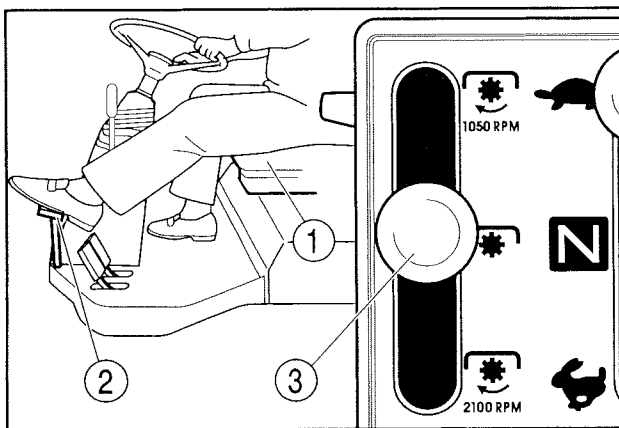

(1) Operator's seat (2) Clutch pedal (3) PTO lever

- a. Sit in the operator's seat properly.

- b. Apply the parking brakes securely.
- c. Shift the transmission range shift lever to the neutral position (N).
- d. Shift the PTO lever to the neutral position (☞).
- e. Shift the lift lever to the down position (↓).
- f. Depress the clutch pedal fully.
- g. Insert the starter key into the starter switch and turn the key to the starting position (⊙).
- h. Observe the monitor lamp array and make sure that the charge lamp and oil pressure lamp are both lit.

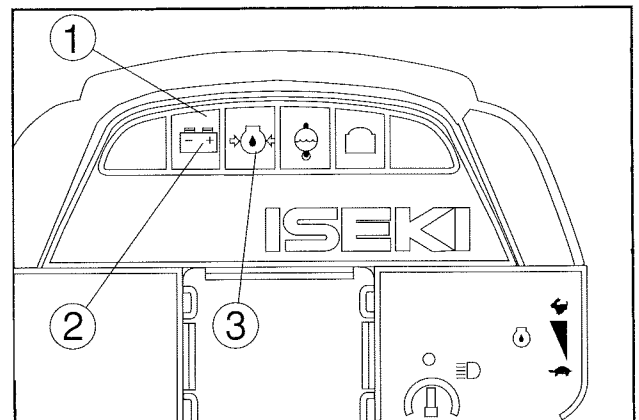

(1) Monitor lamp array (3) Oil pressure lamp
(2) Charge lamp

- i. Turn the throttle lever to the high speed position (⤴).

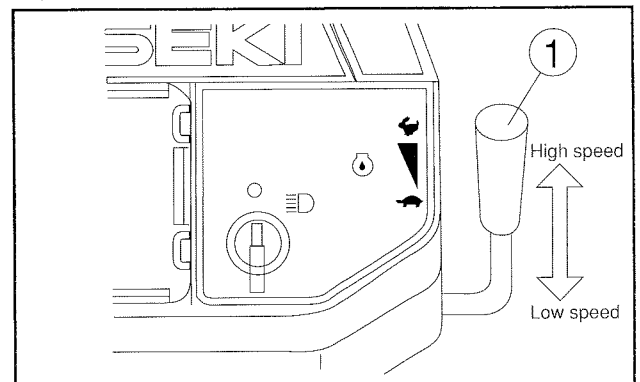

(1) Throttle lever

V. OPERATION

- j. Turn the key to the pre-heating position (⌚) and hold it there about five to ten seconds.

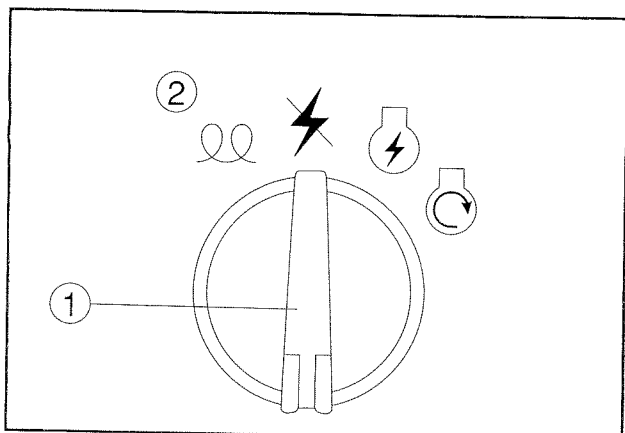

- (1) Starter key
(2) Pre-heating position

Important:

Never keep on activating the glow plugs more than 20 seconds, or they may be burnt out.

When the engine fails to start, wait at least 20 seconds before the next attempt.

- k. Turn the starter key to the starting position (⌚), and the starter is activated to crank the engine.

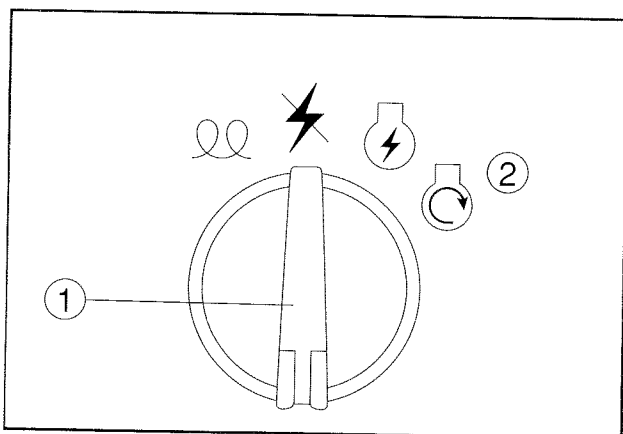

- (1) Starter key
(2) Starting position (⌚)

Important:

Don't operate the starter motor more than 10 seconds. When the engine fails to start, wait at least 20 seconds before the next attempt. If you don't, the battery will be discharged too fast.

- l. As soon as the engine starts, release the starter key. The key will return automatically to the operation position (⌚).

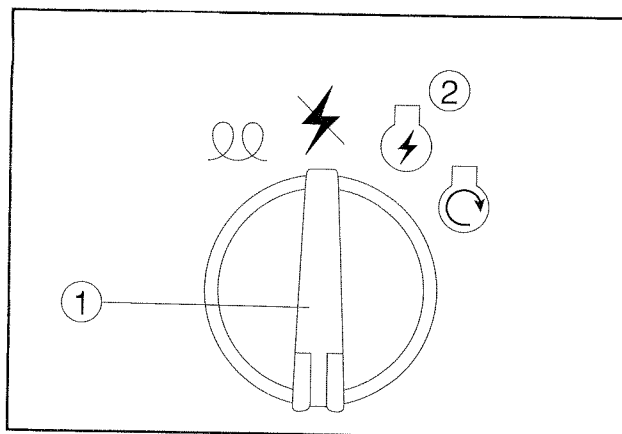

- (1) Starter key (2) Operation position (⌚)

- m. Make sure that the charge lamp and oil pressure lamp turn off.

Important:

If the oil pressure should remain lit, stop the engine immediately and check the engine lubrication system.

- n. When the engine starts, shift the throttle lever to an intermediate speed position, that is, between the high speed and low speed positions (⌚ and ⌚). Let the engine idle for about 10 minutes at least.

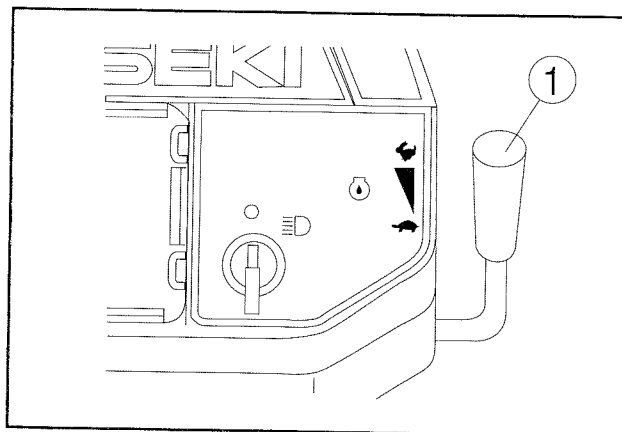

- (1) Throttle lever

Important:

- Never turn the starter key to the starting position (⌚) after the engine starts, or the starter motor will be damaged.

SF303 & SF333

- *Insufficient idling time will cause poor lubrication of the engine due to high viscosity of engine oil, which will lead to a shorter service life of the engine.*



Caution:

- *During engine warming up, be sure to apply the parking brakes to avoid the front mower from travelling unexpectedly.*

Note:

Warming up criteria and atmospheric temperatures:

Higher than 0°C (32°F)	5 to 10 minutes
0°C to -10°C (32°F to 14°F)	10 to 20 minutes
-10°C to -20°C (14°F to -4°F)	20 to 30 minutes
Lower than -20°C (-4°F)	more than 30 minutes

3. STOPPING THE ENGINE

- a. Turn the throttle lever to the low speed position (☛) to reduce engine speeds.

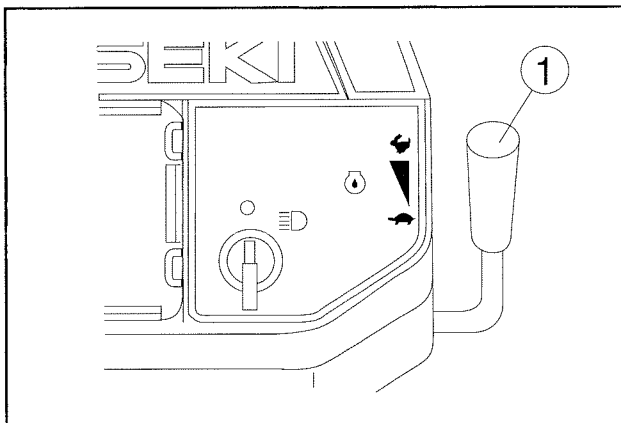

(1) Throttle lever

- b. Depress the clutch pedal and master brake pedal fully. And apply the parking brakes.

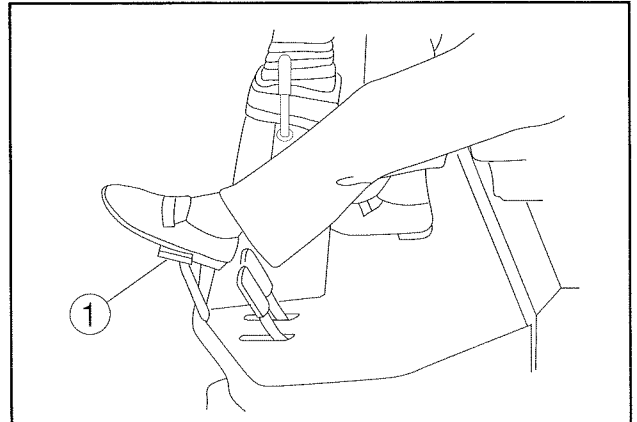

(1) Clutch pedal

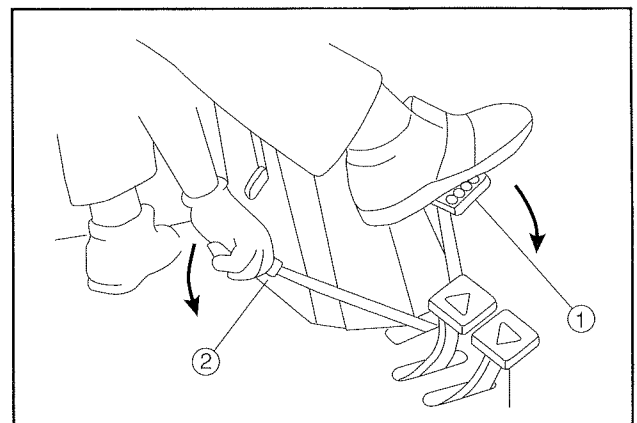

(1) Master brake pedal (2) Parking brake lever

- c. After the front mower stops travelling completely, shift the PTO lever to the neutral position (☛) and make sure that the blades stop completely.

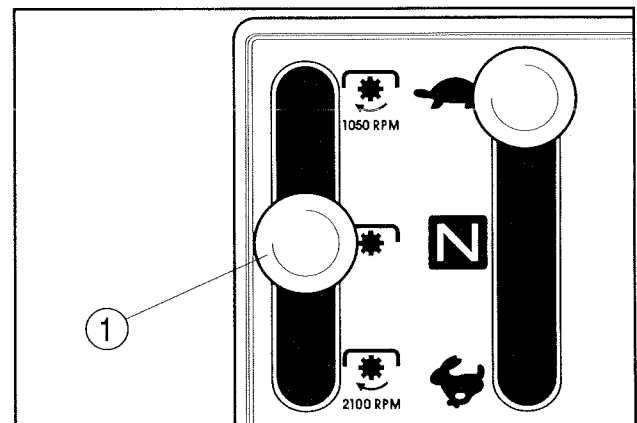

(1) PTO lever



Caution:

- *The mower blades should be stopped completely by turning off the PTO before stopping the engine,*

for it is very dangerous if the blades start rotating if the engine is started unexpectedly.

- d. Shift the transmission range shift lever to the neutral position (N), for it is very dangerous that the front mower starts travelling if the engine is started unexpectedly.

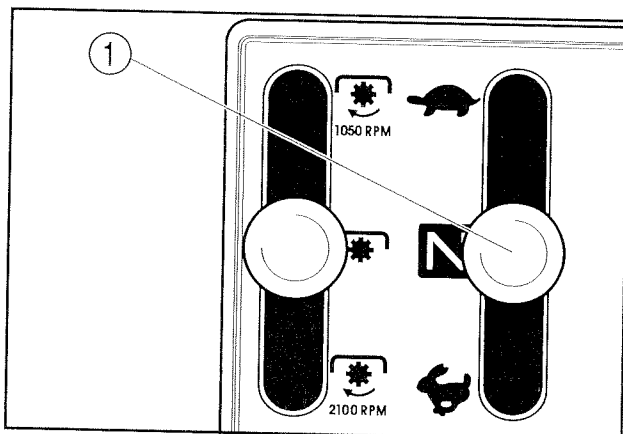

(1) Transmission range shift lever



Caution:

- The transmission range should be shifted to neutral (N) before stopping the engine without fail.

- e. When the front mower stops completely, turn the lift lever to the down position (↓) to lower the mower to the ground.

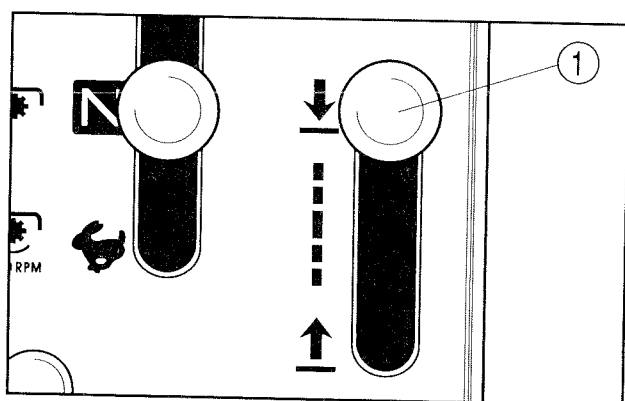

(1) Lift lever

- f. Apply the parking brakes.

- When the parking brake lever is not seated in position smoothly, manipulate the master brake pedal up and down slightly to allow the parking brake lever notch to engage with the master brake pedal.

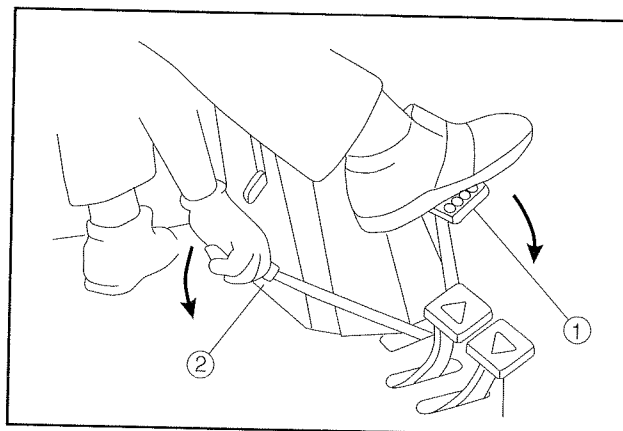

(1) Master brake pedal
(2) Parking brake lever



Caution:

- Be sure to let the engine idle for 5 to 10 minutes after a longtime operation and then stop the engine. Abrupt engine stopping may lead to overheating causing seizure.
- When the master brake pedal is locked completely by the parking brake lever, the pedal should come up only slightly when you take your foot off it. Be sure that the parking brake is applied completely.

- g. Turn the starter key to the off position (★), and the engine stops.



Caution:

- When you leave the front mower, be sure to stop the engine and remove the starter key.
- When parking the front mower, place it on level, hard ground. When there is no alternative but to park it on a slope, be sure to chock all wheels besides applying the parking brake.

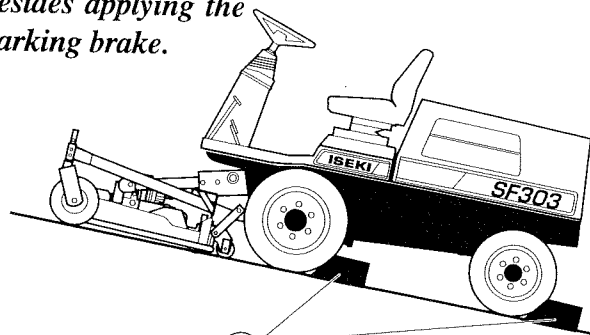

(1) Chocking the wheels

4. OPERATION



Warning:

- Before starting the engine, be sure to carry out the pre-operation inspection in accordance with the periodical inspection table on page 59.
- Abide by instructions mentioned in "I. FOR SAFETY OPERATION."
- Abide by instructions mentioned on the caution labels on the machine.

4.1. MOVING TO A WORKING SITE

- a. Before starting to travel, shift the transmission range shift lever to the low speed position (🐢) or the high speed position (🐇) while depressing the clutch pedal fully.

When driving the front mower to the working site, if the way is level and smooth, select the high speed position (🐇). If not, and such as obstacles in the way or the front mower has to cross a road, select the low speed position (🐢) and operate at sufficiently low speed.

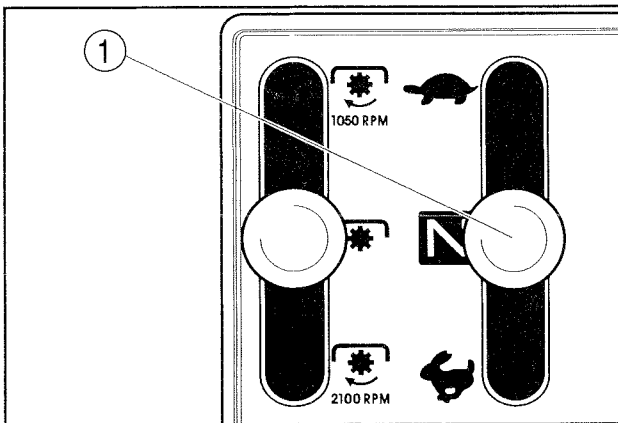

(1) Transmission range shift lever

- b. Turn the throttle lever to the high speed position (🐇) to accelerate the engine.

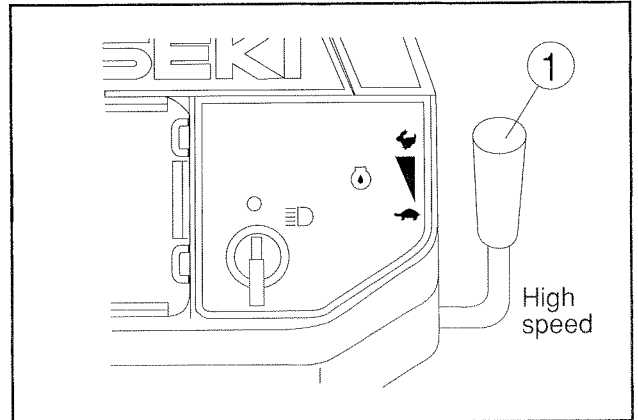

(1) Throttle lever

- c. Turn the lift lever to the up position (↑) to raise the mower above the ground.

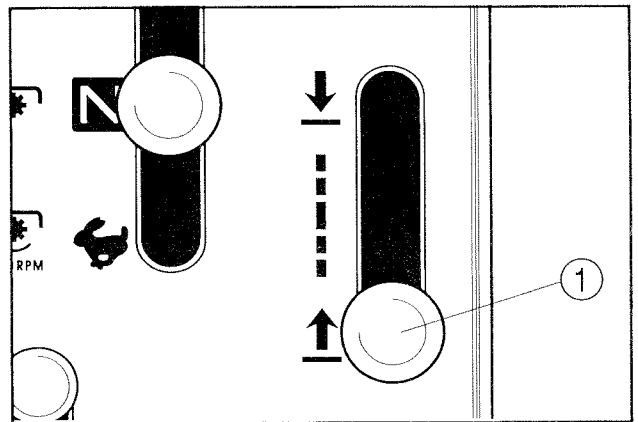

(1) Lift lever

Important:

- Use the lift lock only for inspection, adjustment, and servicing of the mower. The use of the lift lock is prohibited during travelling, for the shocks from travelling may damage the lift lock device and the lift cylinder.

- d. Depress the master brake pedal fully to release the parking brake.

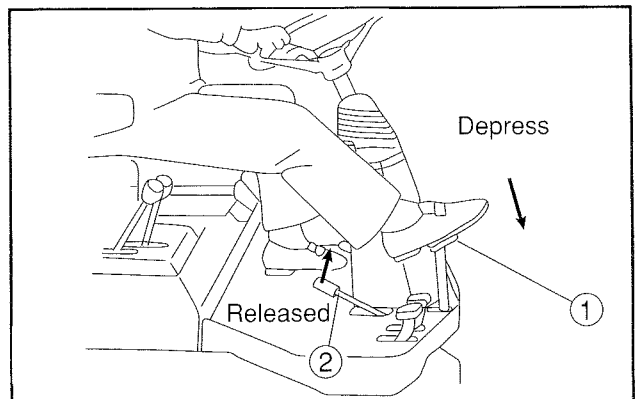

(1) Master brake pedal (2) Parking brake lever

V. OPERATION

- e. Release the clutch pedal gradually.

Never attempt to keep on resting your foot on the clutch pedal, or the clutch is in a half-engaged condition, which will cause the clutch disk to wear quickly or to seize.

Caution:

- *Never release the clutch pedal abruptly, or the front mower may dash forward, which is very dangerous.*
- *Before starting to travel, be sure of the safety around the machine.*

- f. The steering wheel is very light to turn, for the steering system is assisted hydraulically. Naturally the front mower turns to right when the steering wheel is turned clockwise and vice versa.

Caution:

- *Never attempt to turn the steering wheel abruptly during travelling at high speed, or the front mower will make a sharp turn, which is very dangerous.*
- *Never attempt to make a sharp turn on a slope, but slow down sufficiently and turn the steering wheel slowly to prevent the front mower from turning over or falling down.*

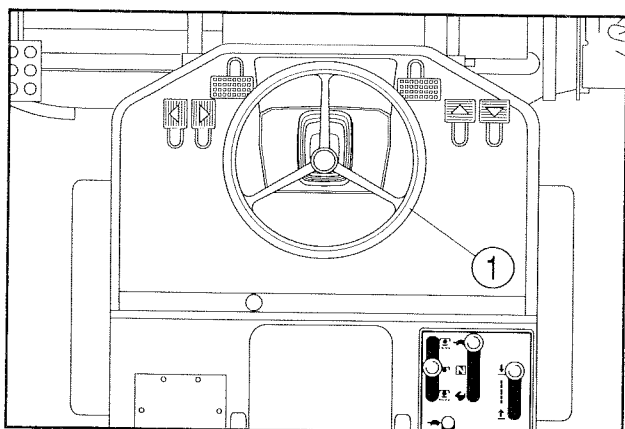

(1) Steering wheel

The steering wheel is tiltable in 4 steps, so choose the optimum angle to suit the operating position.

The steering wheel column is tilted more toward the operator's seat greater than the setting angles mentioned above, but this is for packing not for operation.

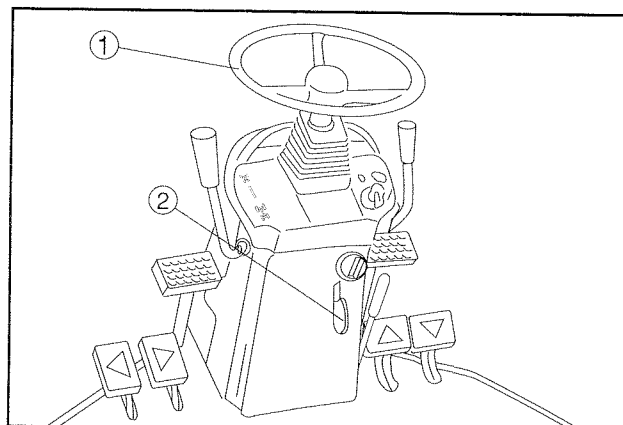

(1) Steering wheel
(2) Tilt lock lever

- g. Depress the HST forward travel pedal softly, and the front mower starts travelling.

Caution:

Never attempt to depress the HST pedal abruptly, or the front mower will dash forward, which is very dangerous.

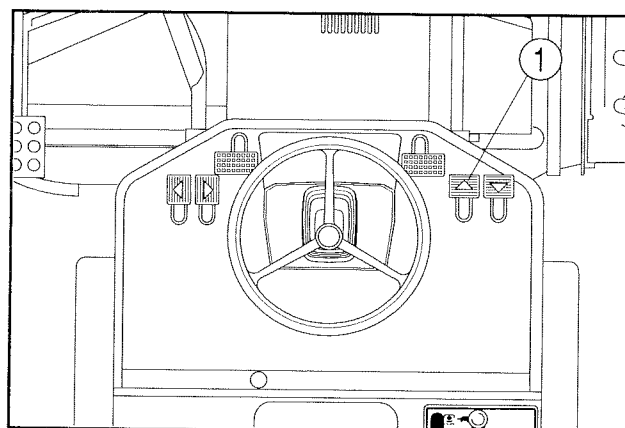

(1) HST forward travel pedal

- h. When reversing the front mower, depress the HST reverse travel pedal softly, and then the front mower starts reversing slowly.

SF303 & SF333



Caution:

- Never attempt to depress the HST pedal abruptly, or the front mower will dash rearward, which is very dangerous.
- When reversing, be sure of the safety behind the front mower.

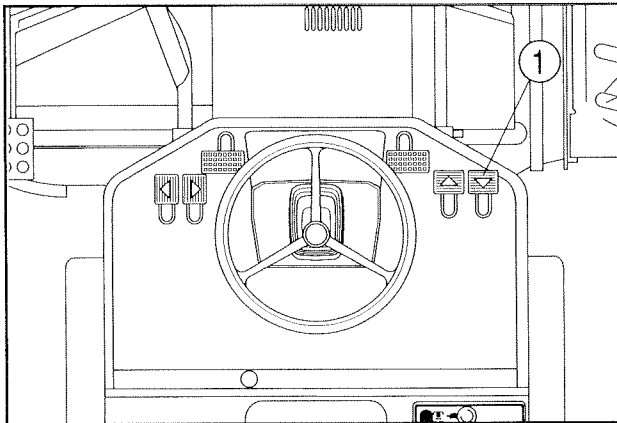

(1) HST reverse travel pedal

Use the cruise control only when the transmission range is shifted in the low speed position (🐢). Never use it in the high speed transmission range for safety. It is very difficult to avoid hazards quickly if the travelling speed is fixed at high rate.



Caution:

When transporting or moving the front mower to another place, never shift the PTO lever to the operation position to allow the mower blades to turn. Rotating the blades during transportation or moving is very dangerous.

4.2. MOWING OPERATION



Caution:

- When arriving at a working place, park the front mower on a hard, level ground.
 - a. Lower the mower on the ground.
 - b. Shift the transmission range to the neutral (N).

c. Apply the parking brake.

d. Stop the engine and remove the starter key.

- Before moving the front mower into the working site, investigate the whole site and get rid of all obstacles such as stones, wood, empty tins, bottles, wires, etc for operation safety.
- Also investigate the site for pits, mounds, steps, slope angles, ground softness, water pools, etc to avoid turning over, falling down, and side-shifting.

- (1) Start the engine and turn the throttle lever to the intermediate position between the low speed and high speed positions.
- (2) Shift the transmission range lever to the low speed position (🐢).
- (3) Turn the lift lever to the up position (↑) to raise the mower.
- (4) Release the parking brake.
- (5) Push down the HST forward travel pedal gradually to drive the front mower into the working site.
- (6) Depress both the clutch pedal and master brake pedal to stop the front mower.
- (7) Turn the lift lever to the down position (↓) to lower the mower on the ground.
- (8) Shift the PTO lever to the high speed position (🌾 2100 RPM).

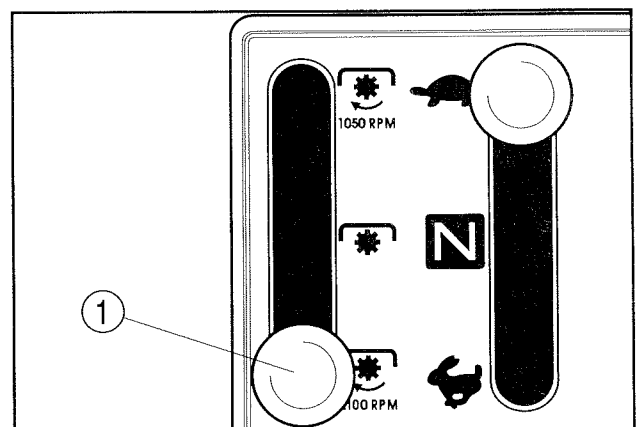

(1) PTO lever

V. OPERATION

The lift height and PTO lever position are interconnected as follows:

Important:

- a. With the PTO lever shifted in the high speed position (☼_{2100 RPM}), the mower does not rise to the maximum height.
- b. With the lift raised to the maximum height, the PTO lever cannot be shifted to the high speed position (☼_{2100 RPM}).

LIFT HEIGHT CONTROL

The lift lever operation and the mower height are interconnected. When the mower is raised higher than the specified level, some force is applied to the lift lever so as to push back the lever to the neutral position.

When it is felt that some force is applied to the lever, turn the lever to the neutral position.

If the lever is kept pushed toward the up position resisting this force, the lift system may be damaged.

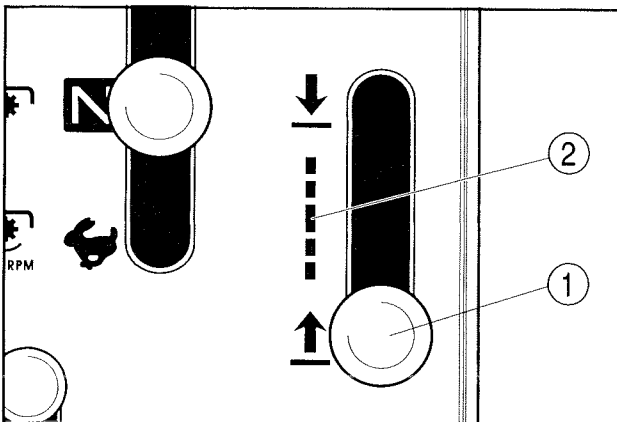

- (1) Lift lever
- (2) Neutral position

This force is applied only when the PTO lever is shifted in the high speed position. The lift regulation does not work with the lever in the low speed position (☼_{1050 RPM}).



Caution:

- **Make sure that the lift height control works properly before starting operation.**
- **When the lift height control does not work properly**

during operation, keep the mower height to a minimum to avoid accidents while the blades are rotating. Before raising the mower, be sure to shift the PTO lever to the neutral position (☼). Never attempt to shift the PTO lever while the mower is raised high.

- (9) Turn the throttle lever to the high speed position (☼) to accelerate the engine.
- (10) Release the master brake.
- (11) Release the clutch pedal gradually. The mower blades start rotating.
- (12) Push down the HST forward travel pedal slowly, and then the front mower starts travelling.



Caution:

- **When the blades start rotating, grass and pebbles start being ejected from the grass discharge. So before starting the mower blades, be sure of the safety around the mower.**
- **When there are abnormal noises and vibrations, stop immediately and locate the source of the trouble. Never start operation without correcting the trouble, or serious trouble may result.**
- **When the source of the trouble is not located, consult your dealers.**
- **When the screens of the air-intakes provided in the front, both sides, and bottom of the bonnet and radiator are clogged with dust and grass, clean them at once. Never keep on operating the machine with clogged screens, or the engine will over-heat.**

VI. MAINTENANCE

1. INSPECTION AND ADJUSTMENT



Caution:

- When servicing the front mower, place it on level, hard ground.
- Stop the engine and remove the starter key.
- Apply the parking brake securely.
- Turn the lift lever to the down position (↓) and lower the mower to the ground.
- Shift the PTO lever to the neutral position (☐).
- Shift the transmission range shift lever to the neutral position (N).

1.1. ENGINE OIL LEVEL

The engine oil level gauge (dipstick) is located on the right sidewall of the crankcase. Draw out the dipstick and wipe it with dry cloth. Then insert it into the engine properly and draw it again. Make sure that the oil level is between the upper and lower limits.

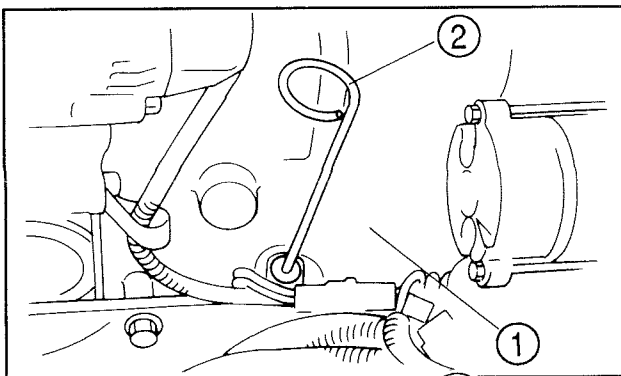

(1) Engine (2) Oil level gauge

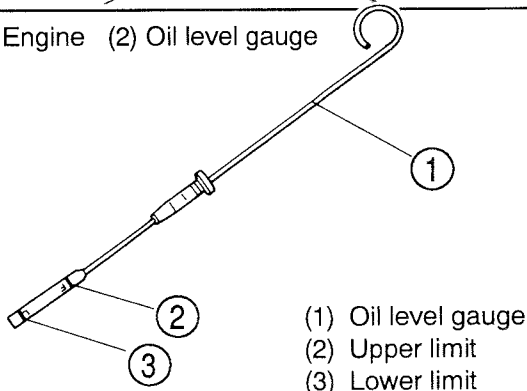

(1) Oil level gauge
(2) Upper limit
(3) Lower limit



Caution:

Stop the engine and wait around 5 minutes at least before checking the oil level. Engine oil is so hot just after operation as to cause burns and it takes some time as well for all the oil to return to the oil pan.

If the level is lower than the lower limit, replenish through the engine oil filler to the upper limit with the same kind of oil as that in the engine.

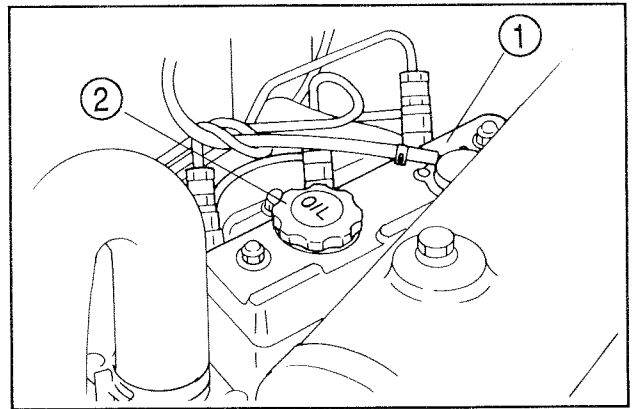

(1) Engine (2) Engine oil filler

Important:

- Never replenish with a different kind of oil. An addition of different kind of oil will deteriorate the quality of the original oil.
- The oil level should not exceed the upper limit. Excessive oil will cause engine trouble.
- Use oil of the quality recommended by ISEKI or CC grade of API classification or higher quality.
- Use oil of proper viscosity in accordance with the atmospheric temperature.

SINGLE VISCOSITY	
SAE 10W	SAE 30
-30 -20 -10 0°C	10 20 30 40
SAE 10W-30	
MULTI-VISCOSITY	
SAE 15W-40	

1.2. TRANSMISSION OIL LEVEL

The transmission oil filler is located under the step. To reach the filler open the step. The filler plug is equipped with the dip stick.

Draw out the dipstick and wipe the tip with dry cloth. Insert the dipstick into the filler properly and remove it again. Make sure that the level is between the upper and lower limits.

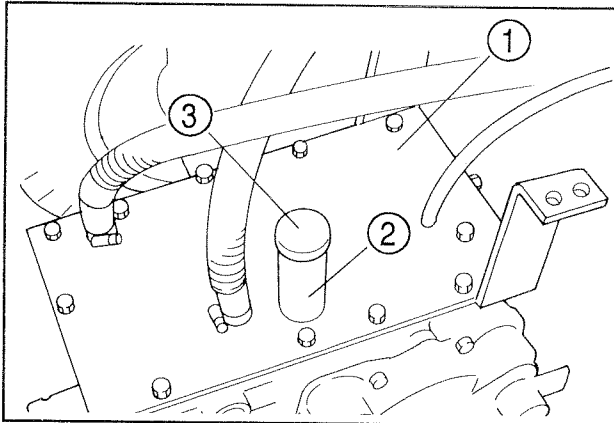

- (1) Transmission
- (2) Transmission oil filler
- (3) Oil filler plug (dipstick)

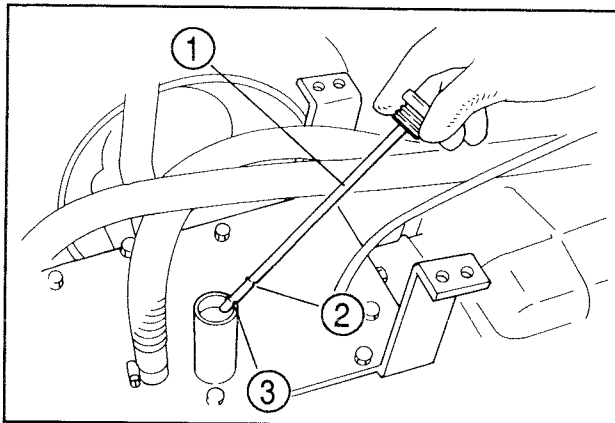

- (1) Dipstick
- (2) Upper limit
- (3) Lower limit

When the oil level is lower than the lower limit, replenish with fresh SHELLDONAX TD (hydrostatic transmission oil).

Important:

The transmission oil is common with oil for the hydrostatic transmission (HST) and the hydraulic lift cylinder, so pay sufficient attention not to allow dust, water, and other foreign matter to be trapped in the oil.

1.3. REDUCTION GEAR CASE OIL

The level plug is located on the right side wall of the clutch housing. Remove the plug with a M14 spanner and check if oil overflows through the plug hole. If so, the level is normal.

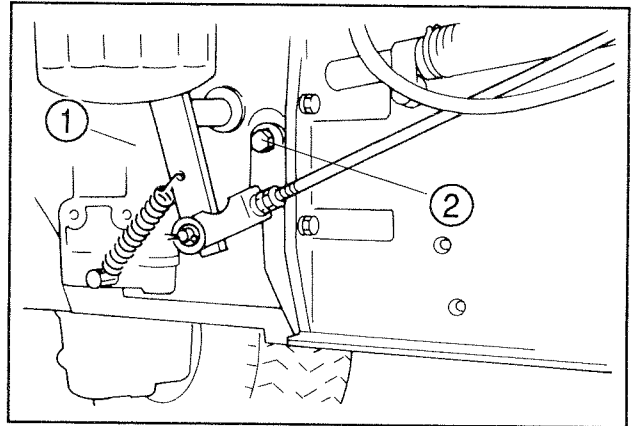

- (1) Clutch housing
- (2) Oil level plug

No oil overflowing shows low oil level. Replenish with fresh gear oil (SAE80) of the same kind as that in the gear case through the oil filler which is located on the right-hand side of the tractor and under the fuel tank.

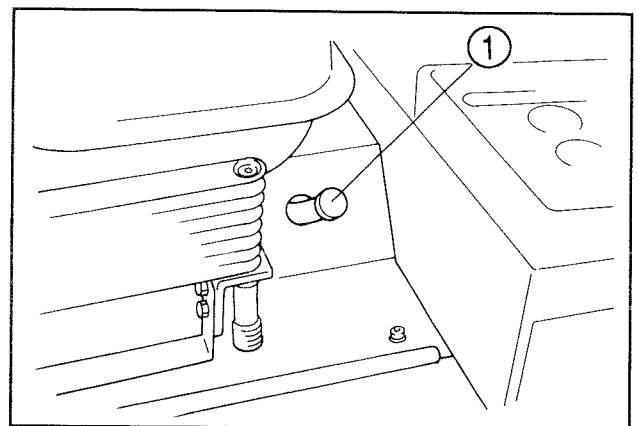

- (1) Reduction gear case oil filler

Important:

Before re-installing the oil level plug, wrap the threads of the plug with sealing tape, or oil may leak out.

SF303 & SF333

1.4. REAR AXLE OIL LEVEL

A level plug is provided on the top side wall of the bevel gear case respectively of the right and left. Remove the plug with a M14 spanner and check to see if the oil overflows through the level plug hole.

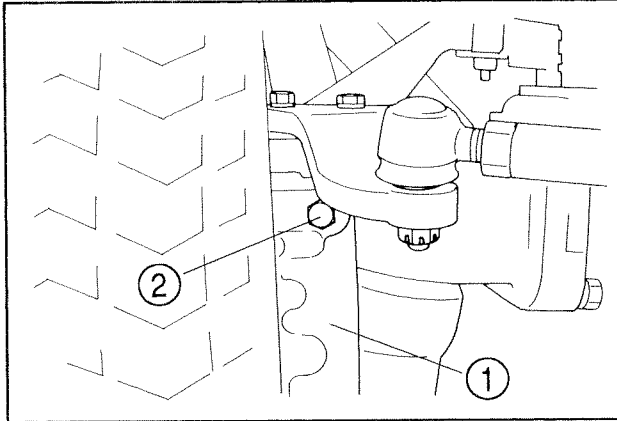

- (1) Bevel gear case (LH)
(2) Level plug

If no oil overflows through the level plug hole, it shows the oil level is lower than specified. So replenish with the same kind of oil as that in the case through the oil filler located on the top wall of the rear axle on the right side of the tractor until the oil starts overflowing through the level hole. Use gear oil of SAE80.

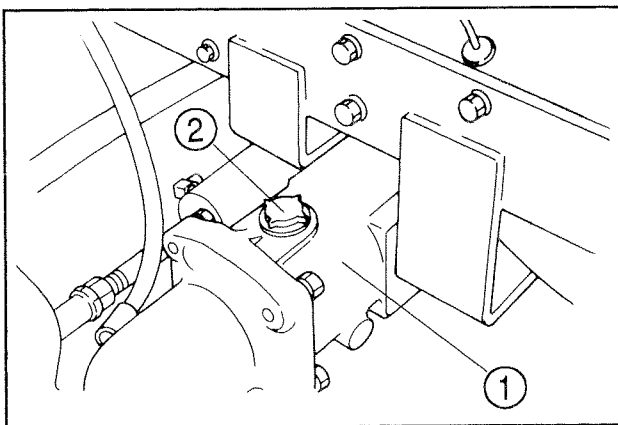

- (1) Rear axle (2) Oil filler

Important:

Before re-installing the oil level plug, wrap the threads of the plug with sealing tape, or oil may leak out.

1.5. COOLANT LEVEL



Warning:

Never remove the radiator cap just after operation. The water in the radiator is very hot and may cause burns. Allow the engine to cool down sufficiently before inspecting coolant level.

Release the engine hood lock lever and open the engine hood.

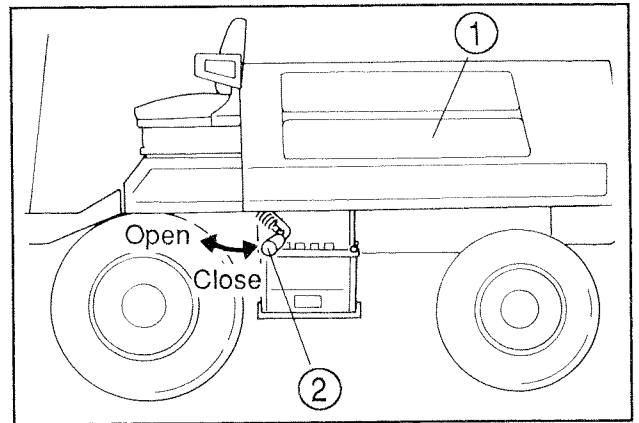

- (1) Engine hood
(2) Engine hood lock lever

Turn the radiator cap counterclockwise until it hits the stopper. Then hold the cap there to release the pressure accumulated inside the radiator. Then turn the cap counterclockwise further while pressing it down, and then it is removed.

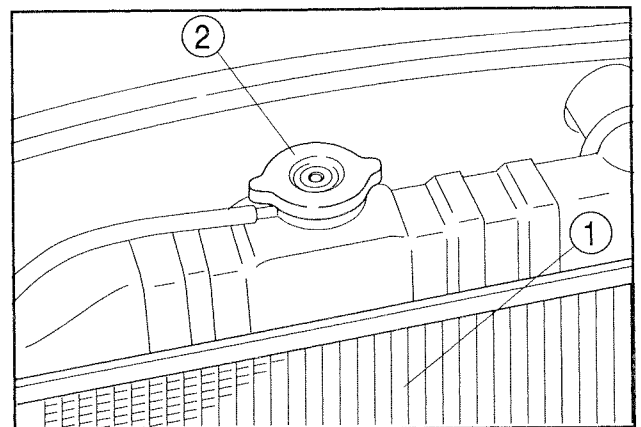

- (1) Radiator (2) Radiator cap

Check to see if the water level is at the bottom of the radiator throat, which is normal. If the level is lower, replenish with fresh clean soft water.

VI. MAINTENANCE

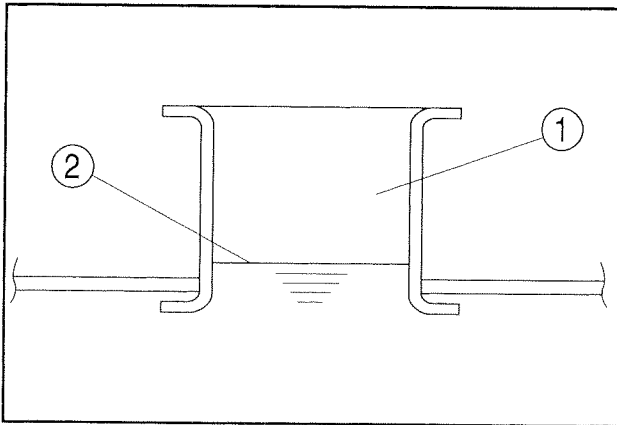

- (1) Radiator throat
- (2) Water level

- Frozen radiator water will damage the engine, so when the atmospheric temperature is presumed to be lower than 0°C (32°F), use antifreeze.
- Before supplying with antifreeze, flush out the radiator and cylinder block.
- Before supplying with antifreeze, it should be mixed well with water in a vessel.
- Mixing ratio of water and antifreeze should be 1:1 by volume.

Replenishment of coolant:

When coolant level is low due to evaporation, replenish with fresh water.

When coolant level is low due to leakage through the breather, replenish with water-antifreeze mixture of 1:1 mixing ratio.

Caution:

Tighten the radiator cap securely, or hot water may gush out through the cap, which is very dangerous.

1.6. FUEL LEVEL

Check to see the fuel level with the fuel gauge on the fender panel. The letter “E” shows the lower limit.

Caution:

- *Before replenishing with fuel, be sure to stop the engine.*

- *Keep sparks, open flames, etc. away from the fuel tank.*

When the fuel gauge pointer turns to “E”, it means only 2.7 liters (0.6 Imp. gal.) of fuel is in the fuel tank. Keeping on operating with this fuel level will cause air to be trapped in the fuel system.

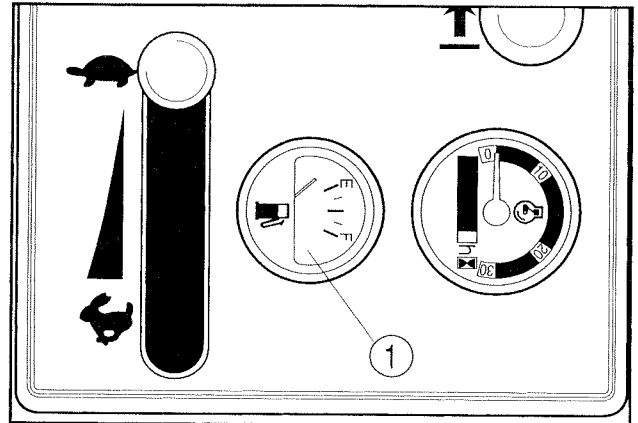

- (1) Fuel gauge

Important:

- *As soon as the fuel gauge shows “E”, replenish with fuel. Use diesel fuel. Never use heavy oil or gasoline (petrol).*
- *Use of fuel other than diesel fuel will cause fuel injection pump trouble.*

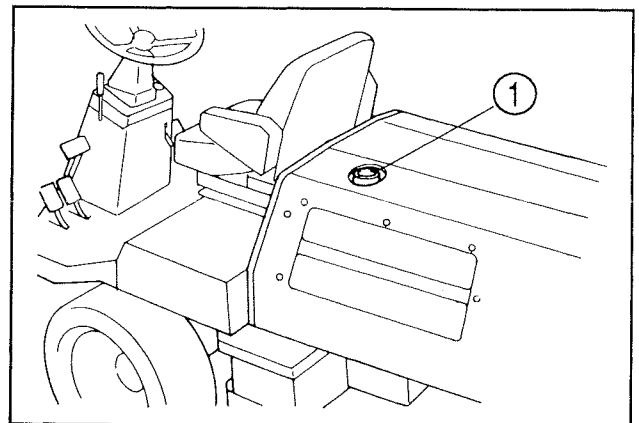

- (1) Fuel filler

Caution:

- *Take care to prevent the fuel tank from overflowing, or it may cause fire.*
- *Should fuel be spilt, wipe off the spilt fuel at once.*

SF303 & SF333

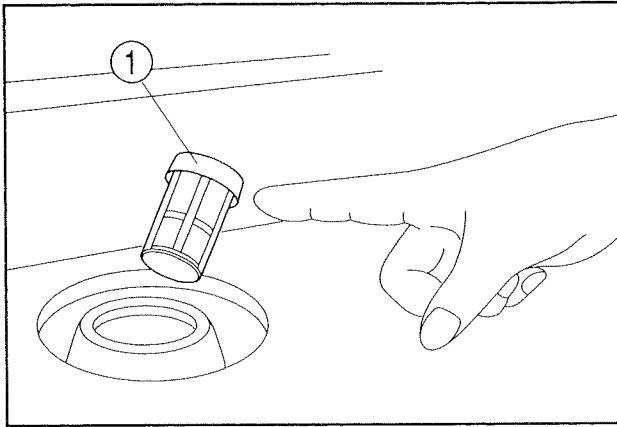

(1) Fuel tank filter

Important:

- A fuel filter is installed inside the fuel filler so as to keep out dust from fuel. Never neglect to use the fuel tank filter when refueling.
- Never refuel exceeding the level on the filter indicated with a finger in the figure. If fuel exceeds the specified level, some fuel will enter without passing through the filter, which means dust in the fuel.
- When the fuel tank cap is removed, it may make a hissing or popping noise. This is due to the cap which is designed to prevent fuel from spilling if the machine falls over. Therefore hissing or popping shows no abnormality.

1.7. AIR-CLEANER

The air-cleaner is held on the engine with the rubber band. Untie this band and pick up the air-cleaner by hand.

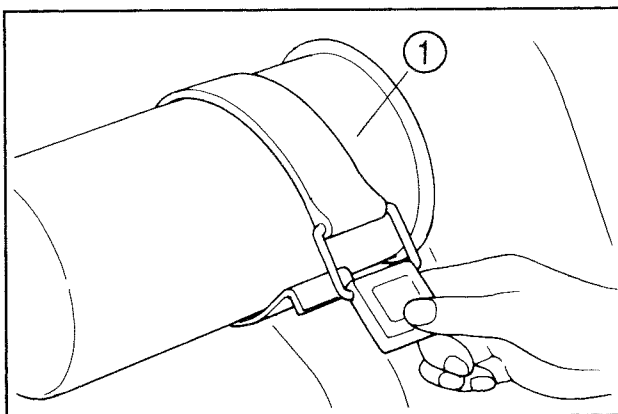

(1) Air-cleaner

Pinch the vacuum valve to eject the dust accumulated inside. When the dust is wet, wipe it off with dry cloth.

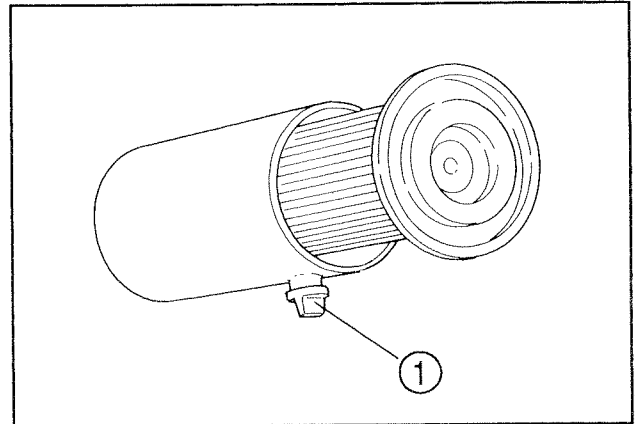

(1) Vacuum valve

Remove the element out of the air-cleaner and dust it off by patting lightly while holding it with the other hand.

When the element does not become clean only by patting, blow dust off the element with compressed air.

When the element does not become sufficiently clean only by blowing, dip it in neutral detergent solution for about 15 minutes and then rinse it in fresh water. Then dry it in the atmospheric temperature.

When water from the tap is used to wash the element, keep the water pressure sufficiently low to prevent the element from damage.

Important:

- Never hit the element against a hard object like a concrete wall.
- Re-install the element into the air-cleaner properly.
- An element which has already been washed five times should be replaced with a new one.
- Never attempt to start the engine without the air-cleaner element. Such operation will cause engine trouble.

1.8. FUEL STRAINER

The fuel strainer is located under the fuel tank on the left side of the tractor. Check the strainer for accumulated dust or water in the bottom of the strainer cup.

When dust or water is found accumulated in the bottom, turn the fuel cock lever by 180 degrees towards the bolt to stop fuel flowing.

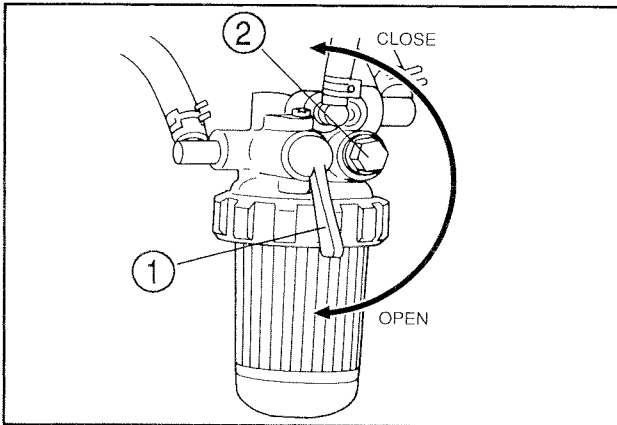

- (1) Fuel cock lever
- (2) Bolt

Remove the ring nut to remove the strainer cup and element. Wash the inside of the strainer cup and element in petrol.



Caution:

- *Smoking is prohibited when the fuel strainer is cleaned.*
- *Keep away sparks and open flames from the strainer.*

Important:

- *Select a clean place to clean the strainer.*
- *Be sure to install the O-ring when re-installing the strainer.*
- *When the fuel tank is emptied and air is trapped in the fuel system, bleed the air as follows:*
 - *Close the fuel filter cock and loosen the strainer cup. Then open the fuel cock and evacuate trapped air completely along with fuel out of the strainer cup. Re-tighten the strainer cup. The air trapped between the fuel pump and injectors is evacuated automatically when the engine is cranked.*

1.9. FAN BELT



Caution:

- *Before checking the fan belt, stop the engine and remove the starter key without fail.*
- *Wait until the engine and accessories cool down completely to prevent burns.*

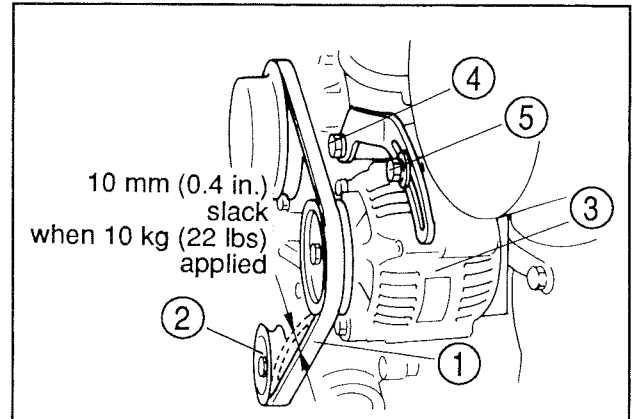

- (1) Fan belt
- (2) Crankshaft pulley
- (3) Alternator
- (4) Lock bolt
- (5) Adjust bolt

The fan belt is accessible from the right rear of the tractor. Open the engine bonnet and check the belt for tension and damage.

Push down the belt with a finger at the intermediate point between the alternator and crankshaft pulley with a force of 10 kgf (22 lb) and see its deflection. If it deflects by about 10 mm (0.4 in.), the tension is proper.

Fan belt tension adjustment:

- a. Loosen the lock nut and adjust bolt of the alternator.
- b. Pull the alternator outward to apply more tension to the belt.
- c. Tighten the lock nut and adjust bolt temporarily while pulling the alternator.
- d. Check for the belt deflection to see if the tension is proper. If so, tighten the lock nut and adjust bolt securely.

SF303 & SF333

1.10. CLUTCH PEDAL PLAY

The specified play of the clutch pedal is 20 to 25 mm (0.8 to 1 in.).

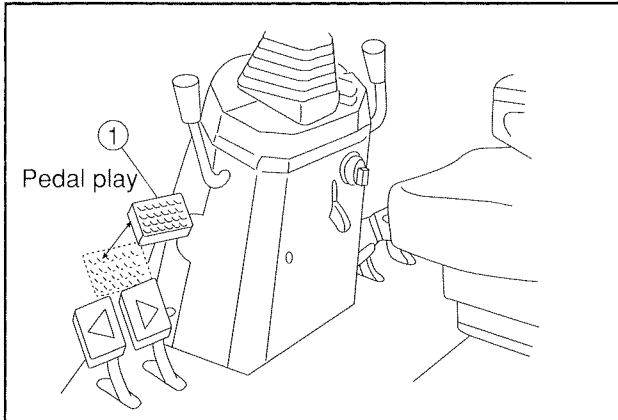

(1) Clutch pedal

When the clutch pedal play is shifted from the specified range, re-adjust it properly, or proper engagement or disengagement of the clutch will become difficult, which is very dangerous.

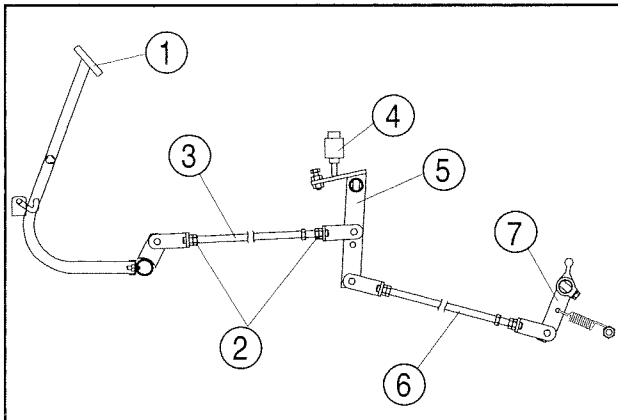

(1) Clutch pedal (5) Arm
(2) Lock nuts (6) Clutch rod B
(3) Clutch rod A (7) Clutch arm
(4) Safety switch

Loosen the locks installed on both ends of the clutch rod A and B. Then turn the clutch rod A and B either clockwise or counterclockwise until the clutch pedal play becomes of a value within the specified range. The longer the effective length of the rods, the larger the clutch pedal play, and vice versa.

Caution:

When the effective length of the clutch rod A changes, the timing to activate the safety switch also changes. Improper switch activating timing may jeopardize the proper safety switch function, which is very dangerous.

Adjust the safety switch activating timing as follows:

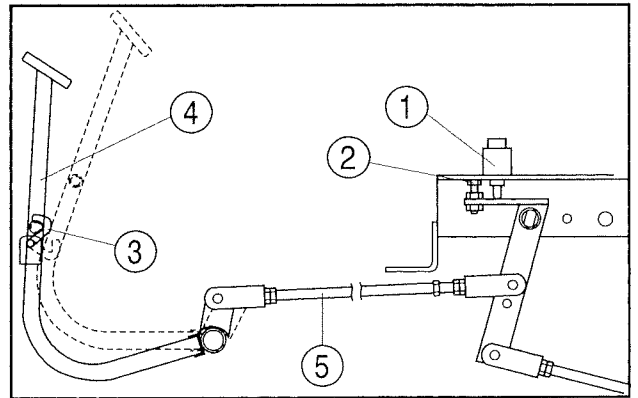

(1) Safety switch (4) Clutch pedal
(2) Adjusting bolt (5) Clutch rod A
(3) Cut-off arm

- Adjust the clutch pedal linkage so that the adjusting bolt head comes into contact with the surface of the safety switch mount about 2 to 3 mm (0.08 to 0.12 inch) before the switch push pin retracts to the end.
- Adjust the clutch rod A so that the bolt head comes into contact with the switch mount surface when the clutch pedal is depressed and hooked on the clutch cut-off arm.

Caution:

- *Be sure to adjust the clutch rod correctly. When the switch pin is pushed in excessively, the safety switch may be damaged.*
- *After clutch pedal adjustment, never fail to re-tighten the lock nuts securely.*

1.11. MASTER BRAKE PEDAL PLAY

The specified play of the master brake pedal is 20 to 30 mm (0.8 to 1.2 in.).

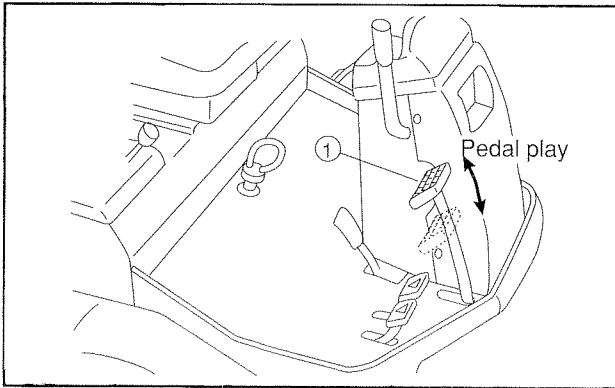

(1) Master brake pedal



Caution:

- As the front mower is used, the master brake pedal play becomes larger. Excessive play will affect the proper brake performance, which is very dangerous.
- Before operation, be sure to check the master brake system.

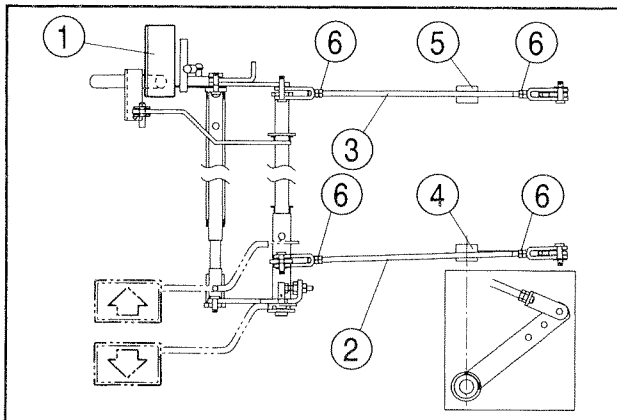

(1) Master brake pedal (2) Brake rod (LH)
 (3) Brake rod (RH) (4) Brake arm (LH)
 (5) Brake arm (RH) (6) Lock nuts

Loosen the 4 lock nuts and turn both the brake rods so as for the master brake pedal to have the specified play. The longer the effective length of the rods, the larger the pedal play, and vice versa.



Caution:

- When the brake rod (LH) is manipulated in effective length, the play of the independent brake pedal (LH) also changes. So the play should also be corrected.
- After pedal play adjustment, be sure to tighten the 4 lock nuts.

1.12. NEUTRAL POSITION OF HST



Warning:

- When the HST unit is out of order, ask your dealers to repair it. Never attempt to disassemble it yourself.
- After a long time of use, the neutral position of the HST unit can shift, which will cause various troubles such as difficulty in stopping the tractor, changing over between forward travel and reverse travel, etc., which is very dangerous.
- The adjustment of the neutral position of the HST unit should be done by your dealers.

- When there is no alternative but for the user to adjust it, follow the next instructions:

The neutral arm of the HST unit is located around the centre on the right side of the tractor. With this arm the neutral position can be adjusted.

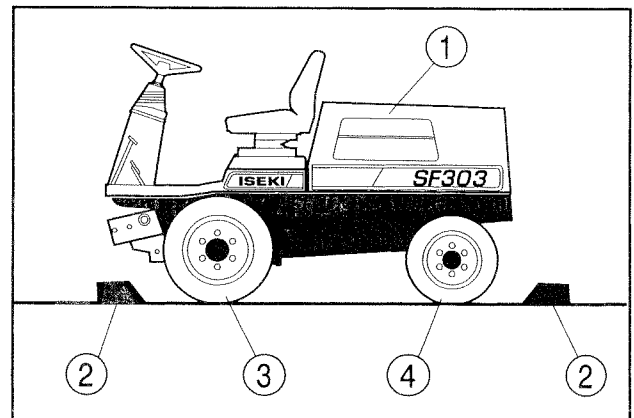

(1) Tractor (2) Tyre chock
 (3) Front wheel (4) Rear wheel

Place the front mower on level, hard ground. Put tyre chocks in the positions a little apart from the front wheels and rear wheels as shown in the figure.

- Shift the PTO lever to the neutral position (☐*).
- When the mower is mounted, raise it to the highest position with the lift lever and apply the lift lock.
- Stop the engine and remove the starter key.

SF303 & SF333

- d. Shift the transmission range shift lever to the neutral position (**N**).
- e. Push down the master brake pedal fully and apply the parking brake.

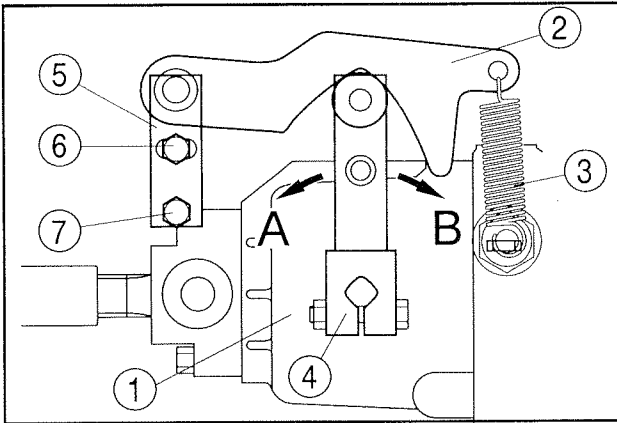

- | | |
|------------------|------------------|
| (1) HST unit | (5) Adjust plate |
| (2) Neutral arm | (6) Adjust bolt |
| (3) Spring | (7) Lock bolt |
| (4) Trunnion arm | |

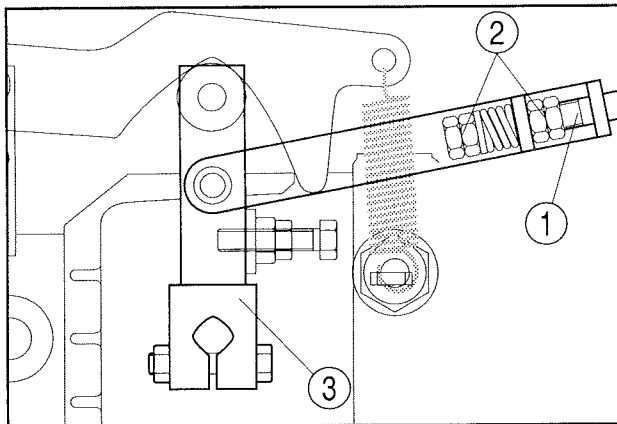

- | | |
|--------------|------------------|
| (1) HST rod | (3) Trunnion arm |
| (2) Lock nut | |

- f. Loosen the lock nut and adjust bolt of the adjust plate with the left hand.
- g. When it is hard to stop forward travel of the tractor, tilt the trunnion arm slightly toward A and tighten it temporarily with the lock nut and adjust bolt.
- h. Start the engine and hold the throttle lever in an intermediate position between the high speed position and the low speed position.
- i. Push down the clutch pedal and shift the transmis-

sion range shift lever to the low speed position.

- j. Push down the master brake pedal to release the parking brake.
- k. Release the clutch pedal gradually.

- When the tractor does not start travelling, it shows that the neutral position is properly set. Tighten the temporarily tightened bolt and nut securely. When the tractor starts travelling forward, repeat the steps from c to i.
 - When the tractor starts reversing, tilt the trunnion arm slightly toward B and tighten the lock nut and adjust bolt temporarily, and repeat the steps from h to m.
- When the tractor does not start moving, the neutral position is proper. So tighten the lock nut and adjust bolt securely.
- Next, align both HST pedals in height by adjusting the effective length of the HST rod with the lock nuts. Be sure to tighten the lock nuts securely after adjustment.

- l. Loosen the lock nut of the trunnion arm bolt and screw in the bolt slightly to shorten the effective length.

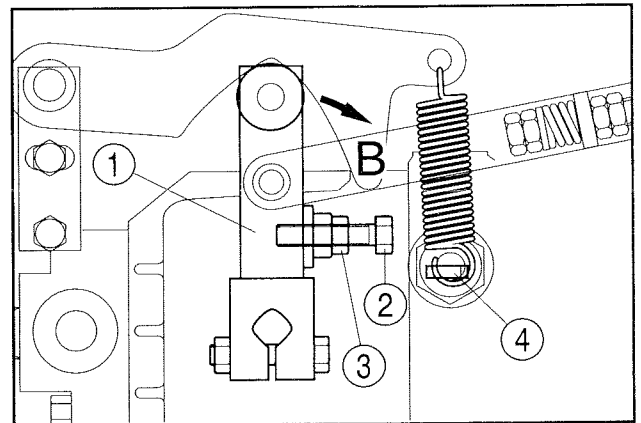

- | | |
|------------------|--------------|
| (1) Trunnion arm | (3) Lock nut |
| (2) Stopper bolt | (4) Stopper |

- m. Lift up the neutral arm with the left hand and turn the trunnion arm toward B until it stops.
- n. Then adjust the effective length of the stopper bolt until the head comes into contact with the stopper by repeating step "m".

VI. MAINTENANCE

1.13. INDEPENDENT BRAKE PEDALS (LH & RH)

When the adjustment of the master brake pedal play may affect the height of both pedal tops. If so, correct the height of the left-hand pedal top to align with the right-hand pedal top by adjusting the effective length of the stopper bolt.

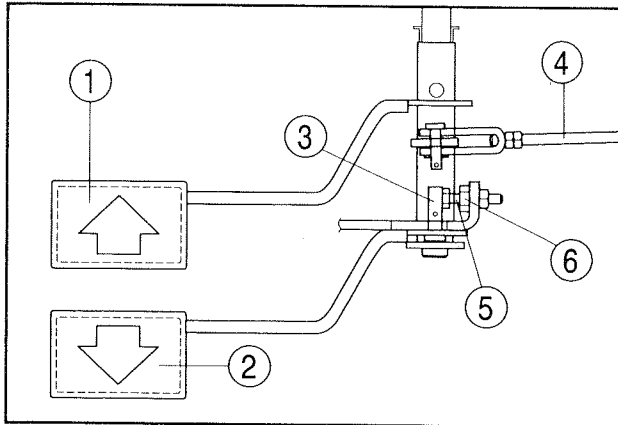

- (1) Independent brake pedal (RH)
- (2) Independent brake pedal (LH)
- (3) Pin
- (4) Brake rod (LH)
- (5) Stopper bolt
- (6) Lock nut

Important:

Never fail to tighten the lock nut of the stopper bolt securely after adjustment.

1.14. BATTERY

The battery is installed on the middle of the left-hand side of the tractor. Check to see if the electrolyte level is between the upper and lower limits.

When the level is near to the lower limit or below, raise the level with distilled water or electrolyte.



Caution:

- *Be sure to connect the battery terminals correctly.*
- *Battery electrolyte is very corrosive and will cause burns, so if it splashes on skin or clothes, wash it off immediately.*
- *Never allow electrolyte to enter your mouth.*
- *When working around the battery, take measures to protect your eyes and face.*

- *The battery generates very explosive gases, so avoid smoking and keep sparks and open flames away from the battery.*
- *The wiring from the battery should be kept clean and connectors tight. Dirty or loose wiring may cause a fire.*
- *When disconnecting the battery, disconnect the negative terminal first.*

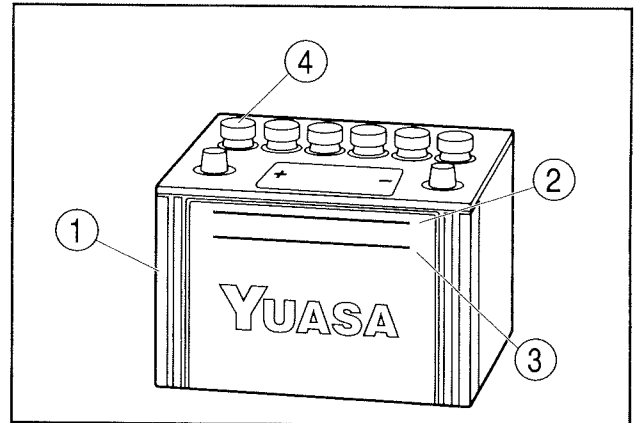

- (1) Battery
- (2) Upper limit
- (3) Lower limit
- (4) Filler plug

Important:

- *The electrolyte level should always be kept between the upper and lower limits. A too low level will damage the battery and a too high level will cause the electrolyte to overflow and corrode other parts.*
- *As the atmospheric temperature lowers, the battery capacity decreases. So the battery should be attended to more carefully in winter.*
- *When the front mower is going to be stored for a long time, remove the battery and store it in a place which is dry and not exposed to direct sunshine.*
- *The battery discharges even while it is not in use. So it should be charged periodically.*

Summer: every month

Winter: every two months

- *When replacing the battery, use a battery of the same capacity as that of the current one.*

Capacity: 12V 55Ah

- *There are two types of battery standards, the L type and R type, whose terminal positions differ. Only the R type battery can be used for the front mower. The length of the battery cables do not fit to L type batteries.*

SF303 & SF333

1.15. TYRE PRESSURE (INFLATION)

Improper tyre pressure causes the tyres to wear abnormally and affects the front mower performance. Too high pressure causes the front mower to bounce too much and too low pressure increases travelling resistance, which leads to power loss.

Tyre pressure should be checked everyday.

	Tyre size	Pressure
Front	23 x 10.5 -2	1.4 kgf/cm ² (20 psi)
Rear	20 x 8.0 - 10	1.6 kgf/cm ² (23 psi)

1.16. TOE-IN

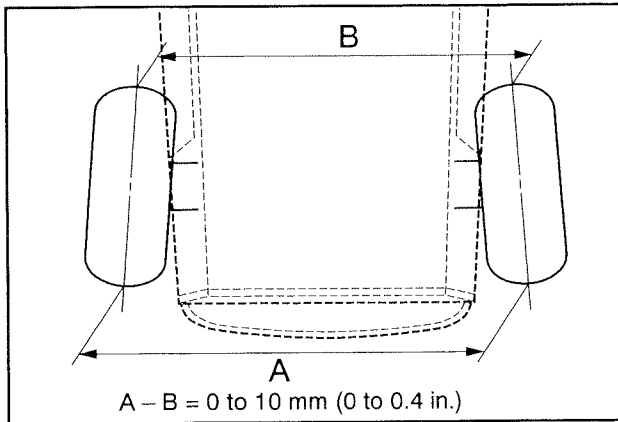

Improper toe-in causes unstable steering of the front mower: the machine has a tendency to turn in one direction, right or left or the steering wheel turns unexpectedly.

The toe-in should be 0 to 10 mm (0 to 0.4 in.).

The toe-in is adjusted by removing the right and left tie-rods from respective final cases, loosening the lock nuts, and turning the right and left tie-rod ends.



Caution:

- *The screwed-in depths of both tie rod ends should be the same.*
- *After adjustment, re-tighten the lock nuts securely.*

- *When installing the tie-rod ends on the final cases using the spring washers and castle nuts, retain the nuts with new cotter pins.*

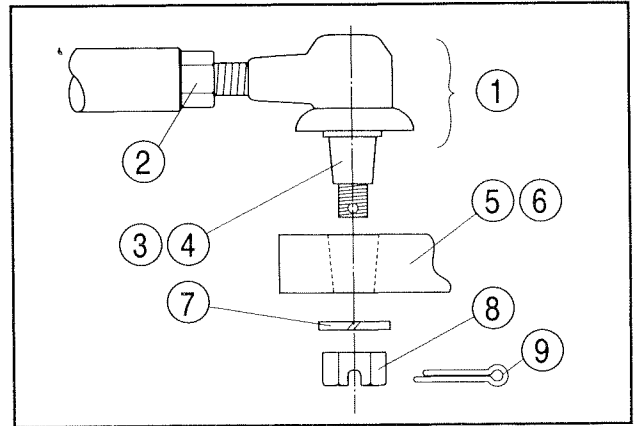

- (1) Tie-rod assembly
- (2) Lock nut
- (3) Tie-rod end (LH)
- (4) Tie-rod end (RH)
- (5) Final case (LH)
- (6) Final case (RH)
- (7) Spring washer
- (8) Castle nut
- (9) Cotter pin

2. REPLACEMENT OF OIL AND OIL FILTER

2.1. ENGINE OIL REPLACEMENT

Important:

- *The engine oil should be replaced with fresh oil in accordance with operation hours. If not, overly used oil will cause engine troubles.*
- *The first replacement should be done after the initial 50 hours of operation and then after every 100 hours of operation.*

When replacing engine oil, place the tractor on level, hard ground.

The engine oil drain is located bottom of the engine oil pan, which is accessible from the left side of the tractor.

The engine should be warmed up for 10 minutes or so ahead of time to heat the oil to lower its viscosity for complete drainage.

Normally, with engines, the filler cap is removed in advance to allow the oil to drain out easily. However, if the cap is removed, absolute care must be taken to prevent dust from entering through the filling hole.

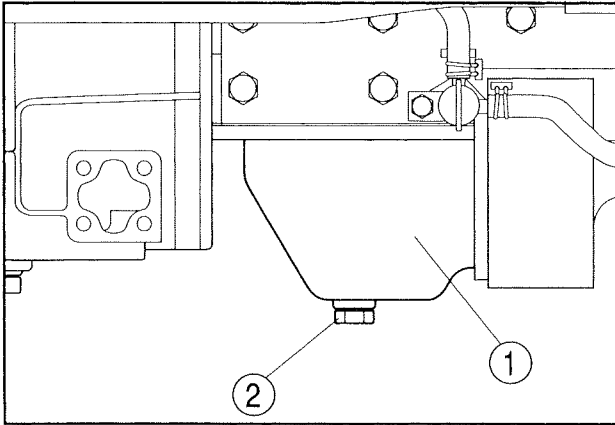

- (1) Oil pan
- (2) Drain plug

Place an oil receiver (a tray) below the engine and remove the drain plug allowing the used oil drain out.

When the used oil has drained out completely, screw the drain plug back in securely. Pour in fresh engine oil through the oil filler.

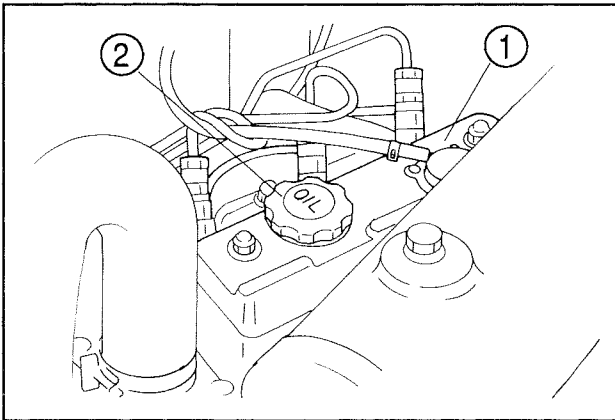

- (1) Cylinder head cover
- (2) Filler cap

Be sure to use the oil recommended by ISEKI. Refer to "ENGINE OIL LEVEL INSPECTION" on page 27.

Engine oil capacity: 3.2 litres (0.7 Imp. gal.)

After engine oil replacement, start the engine and let it idle for a while. Then stop it and wait for a while until the engine oil comes down into the oil pan. Now check the oil level to check to see if it is at the upper limit or not. When the level is low, replenish until the level reaches the upper limit.

Note:

Never fill over the upper limit, or it may cause engine trouble.

2.2. ENGINE OIL FILTER REPLACEMENT

Important:

- The engine oil filter should be replaced after every 300 hours of operation.
- Place the tractor on level, hard ground when replacing the oil filter.
- Idle the engine for 10 minutes or so ahead of time.

Place a tray under the engine oil drain.

Remove the drain plug to let the engine oil drain out.

The engine oil filter is located on the left-hand wall of the cylinder block.

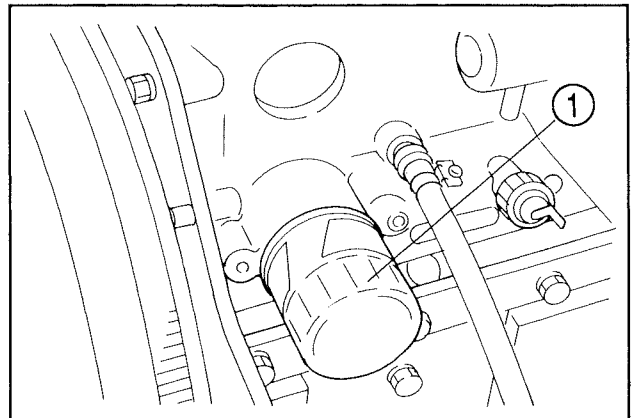

- (1) Engine oil filter

Hold something like waste cloth or soft paper under the filter to receive dripping oil when the filter is removed.

Loosen the filter using a filter spanner and remove it. Install a new filter.

Screw in the filter until its packing comes into contact with the sealing surface of the engine and then tighten it by a 3/4 turn with the filter spanner.

Re-install the drain plug securely. Open the fuel filler cap and pour the drained oil back in.

SF303 & SF333

Important:

- When re-filling with the temporarily drained oil, take care not to allow foreign matter into the oil.
- It is recommended to filter the drained oil ahead of time with something like a fine mesh cloth.
- Start the engine and let it idle for a while until oil fills the filter.
- Check the drain plug and oil filter for oil leakage.
- Stop the engine and check the oil level. If the level is lower than specified, replenish with fresh engine oil of the same kind that in the engine.

2.3. TRANSMISSION OIL REPLACEMENT

Important:

- The transmission oil should be replaced after the initial 50 hours of operation and then after every 200 hours of operation.
- Place the tractor on level, hard ground.

The transmission oil drain is located on the bottom centre of the tractor.

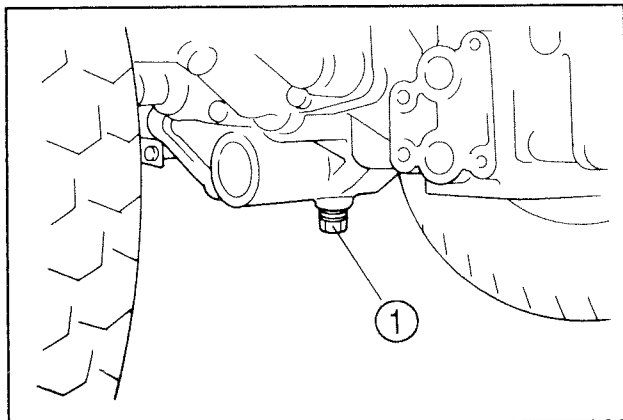

(1) Drain plug

Place a tray under the drain plug. Remove the drain plug and let the oil drain out.

TRANSMISSION OIL FILTER

Important:

The transmission oil filter should be changed every time the oil is replaced.

The transmission oil filter is located centre of the right-hand side of the tractor.

After the oil has drained out completely, remove the filter using the filter spanner.

When removing the filter, a small amount of oil may spill, so place waste cloth or a tray under the filter to receive spilled oil.

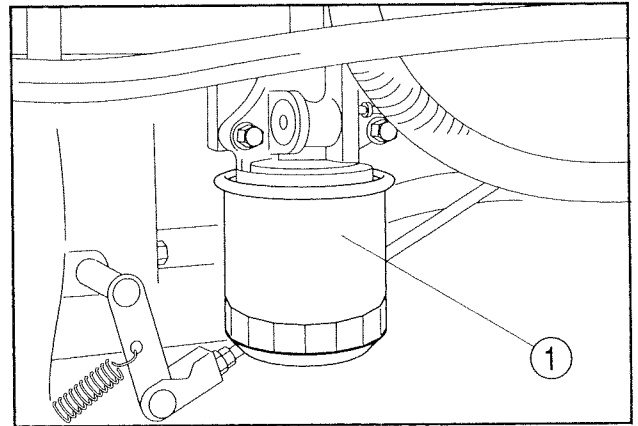

(1) Transmission oil filter

Half-fill the new oil filter with oil and apply some to the O-ring ahead of time. Then install the filter. Screw in the filter by hand until it is tight, and then screw in it by a 3/4 turn with the filter spanner.

Oil: SHELLDONAX TD (Hydrostatic transmission oil)

SUCTION FILTER

The suction filter should be cleaned by washing it every time the transmission oil is replaced.

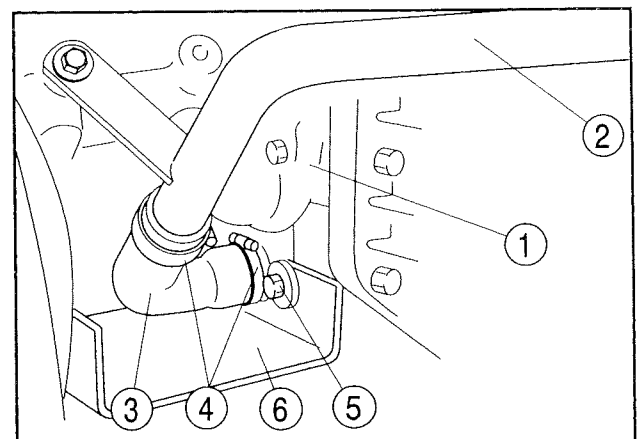

(1) Transmission case (4) Hose clips
(2) Suction pipe (5) Bolts
(3) Rubber hose (6) Suction cover

VI. MAINTENANCE

The suction filter is located bottom left of the transmission case.

Detach the rubber pipe connecting the suction filter and the suction pipe by removing the hose clips.

Remove the suction cover by removing the three tightening bolts.

Draw the suction filter out of the transmission case.

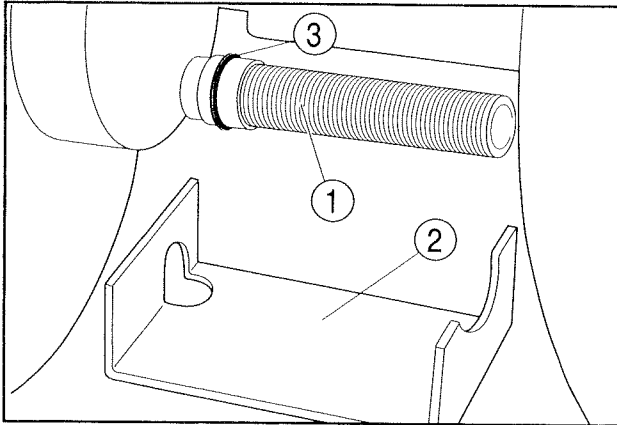

- (1) Suction filter
- (2) Suction cover
- (3) O-ring

Wash the filter in fresh cleansing oil.

Note:

The inside of the removed hose should also be cleaned.

Install the cleaned suction filter into the transmission case, taking care not to deform the O-ring.

Install the suction cover.

Connect the rubber hose and tighten both ends with the hose clips.

Important:

- *When installing the suction cover, be sure to retain the suction filter shoulder with the washers of the tightening bolts.*
- *A damaged suction filter should be replaced with a new one.*

Screw the drain plug back in securely.

Pour fresh oil through the oil filler located on the top of the transmission case.

Fill until the oil level reaches the upper limit on the dipstick of the filler plug.

Transmission oil	SHELLDONAX TD (Hydrostatic transmission oil)
Capacity	11 litres (2.4 Imp. gal.)

After filling with transmission oil, start the engine and let it idly for a while. Then check the oil level again. If the level is lower than the upper limit, replenish until the level reaches the upper limit.

Check the oil filter, suction filter, rubber hose, and drain plug for oil leakage.

2.4. REDUCTION GEAR CASE OIL REPLACEMENT

Important:

- *The oil in the reduction gear case should be replaced after the initial 50 hours of operation and then after every 200 hours of operation.*
- *Place the front mower on level, hard ground.*

The drain of the reduction gear case is located on the bottom of the case on the left-hand side of the tractor.

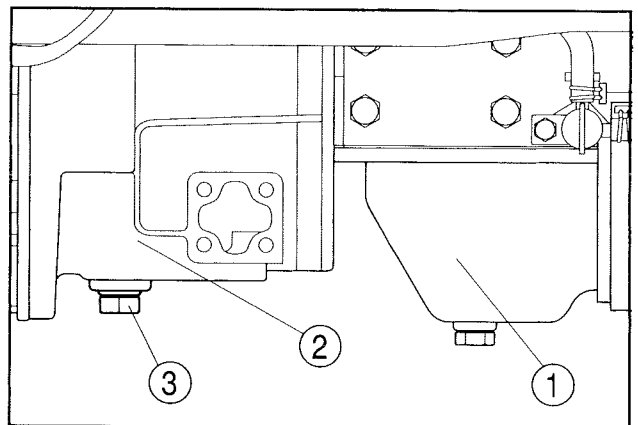

- (1) Engine oil pan
- (2) Reduction gear case
- (3) Drain plug

Place a tray under the drain plug.

Remove the drain plug using a M14 spanner.

After the oil has drained out completely, screw the drain plug back in securely.

SF303 & SF333

Pour fresh gear oil through the filler located below the fuel tank.

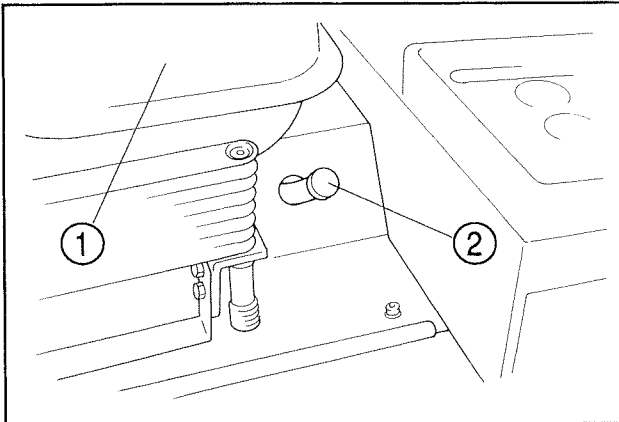

(1) Fuel tank (2) Oil filler

Oil	Gear oil SAE80
Capacity	0.7 litre (0.15 Imp. gal.)

The level of the reduction gear case oil is checked with the level plug located on the right side wall of the clutch housing.

Remove the level plug using a M14 spanner and check to see if a small amount of oil overflows through the plug hole, which shows the proper level.

If oil does not overflow, replenish until oil overflows through the level plug hole.

Important:

Before re-installing the level plug, wrap the threads of the plug with sealing tape. If not, oil may leak out through the plug.

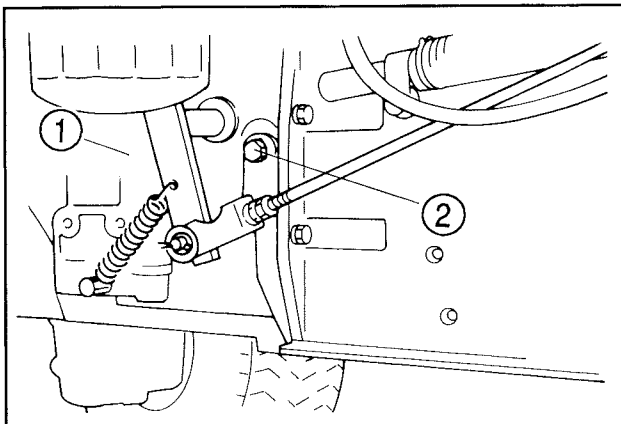

(1) Clutch housing (2) Level plug

2.5. REAR AXLE OIL REPLACEMENT

Important:

- The rear axle oil should be replaced after the initial 50 hours of operation and after 200 hours of operation.
- Place the front mower on level, hard ground.

The rear axle drain plug is located on the bottom of the right and left gear cases.

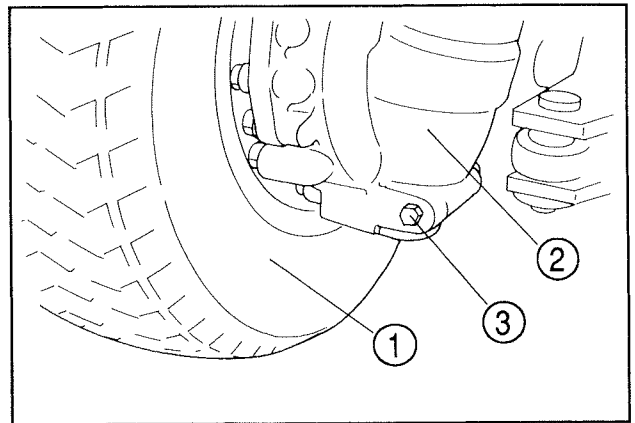

(1) Rear wheel (LH) (2) Gear case (LH) (3) Drain plug

Place a tray under the drain plug.

Remove the drain plug using a M14 spanner.

Let all oil drain out from both the gear cases.

Wrap the threads of the drain plug with sealing tape and screw it back in securely.

Pour in oil through the oil filler on the top of the right-hand rear axle.

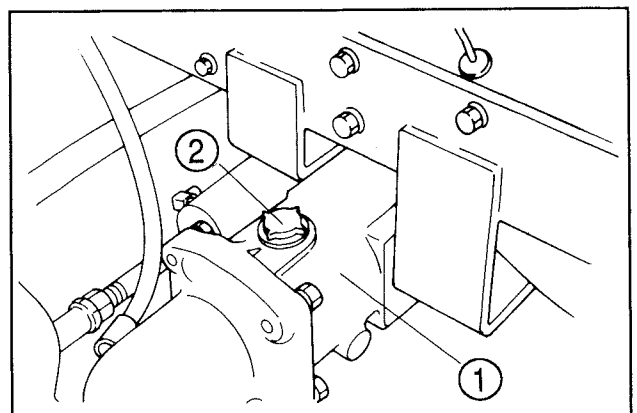

(1) Rear axle (2) Oil filler

VI. MAINTENANCE

Oil	Gear oil SAE80
Capacity	4.1 litres (0.9 Imp. gal.)

The oil level plug is located on the upper part of each gear case.

Remove the level plug using a M14 spanner and check to see if a small amount of oil overflows through the plug hole, which shows the proper level. If oil does not overflow, replenish until oil overflows through the level plug hole.

Important:

Before re-installing the level plug, wrap the threads of the plug with sealing tape. If not, oil may leak through the plug.

3. RADIATOR INSPECTION AND CLEANING

3.1. RADIATOR CLEANING

A radiator and radiator screen clogged with dust or dirt causes overheating of the engine due to deteriorated cooling efficiency of the radiator. The radiator and radiator screen should be checked for clogging everyday before operation.

When mowing dead grass or operating under extremely dusty conditions, check the radiator and radiator screens several times a day to avoid clogging.

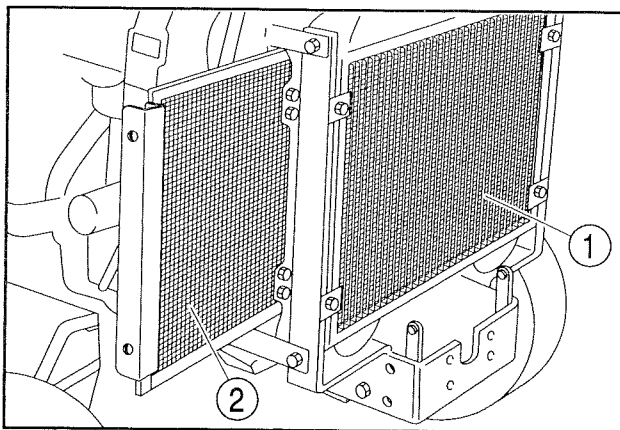

- (1) Radiator
- (2) Radiator screen

The radiator is located on the rear part of the tractor. The radiator screen is installed between the radiator and the cooling fan.

The radiator screen is held on the left side of the radiator with two wing bolts.

Remove the wing bolts and draw out the radiator screen.

Dust off the radiator screen with a soft brush. When it is clogged excessively, use compressed air or water. If it is washed, let it dry in the atmospheric temperature.

The clogged radiator fins should be cleaned by applying compressed air or water from both sides alternatively.

Install the radiator screen and tighten the wing bolts.



Caution:

Be sure to stop the engine and remove the starter key before cleaning the radiator. Unexpected engine starting is very dangerous.

3.2. COOLANT REPLACEMENT



Caution:

Never attempt to remove the radiator cap just after operation, or pressurized vapor and hot water will gush out, which may cause burns. So wait until the engine cools down sufficiently.

When there is a possibility for coolant to freeze, use antifreeze without fail.

The drain cock of the engine coolant is located bottom-left of the engine.

Place a coolant receiver under the drain cock and remove the radiator cap.

Open the drain cock to let all coolant drain out of the radiator and engine cylinder block.

When all coolant completely drained out, close the drain cock securely.

SF303 & SF333

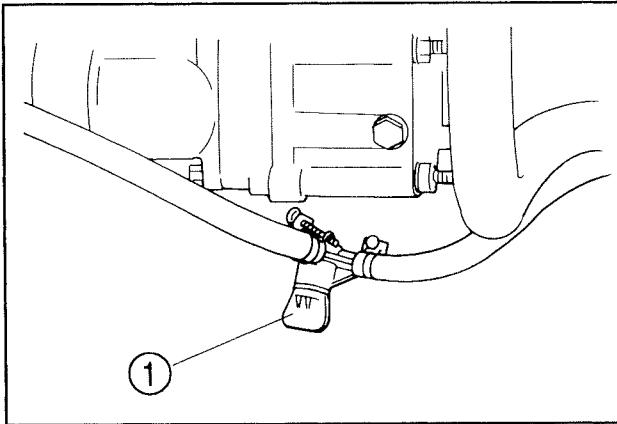

(1) Drain cock

Important:

- Use pure soft water as coolant, or scale and rust will accumulate inside the cylinder block and radiator, which leads to deterioration of the cooling efficiency of the engine.
- Mixing ratio of water and antifreeze is 1:1. They should be well mixed before filling. Never pour them into the radiator separately.

Coolant capacity	5.3 litres (1.2 Imp. gal.)
------------------	----------------------------

After filling, start the engine and let it idle for 5 minutes or so. Then check the coolant level. If the level is low, replenish with coolant.

Important:

- Never attempt to run the engine without coolant, or the engine seize, leading to its complete damage.

4. INSPECTION OF FUSES AND WIRING

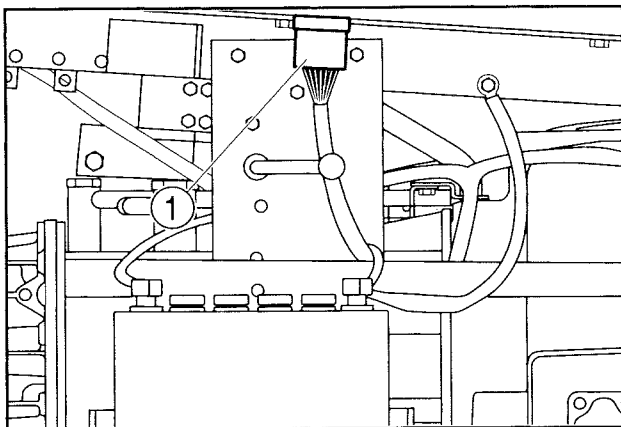

(1) Fuse box

Important:

Be sure to use specified fuses. Larger-capacity fuses will cause burn-out of electric accessories and wiring.

The fuse box is located under the fuel tank left-center of the tractor.

Fuse capacity	Application
3A	Fuel pump
10A	Solenoid
10A	Lamp relay
20A	Other implement



Caution:

- The 20A fuse in the fuse box is not a spare fuse. It is installed to provide power to the electric system of an implement other than the mower. Never use it in place of the other fuses.
- Never replace blown fuses or fusible links with wire except in an emergency.

Important:

When a fuse is blown, be sure to locate the trouble and correct it. When the cause is not clear, consult your dealers.

The alternator and the starter motor have their own fusible links. When a link is melted down, locate the trouble and ask your dealers to correct it.

When a fusible link is melted down, use an ISEKI genuine link.

Fusible link:	Code No. 3652-261-2020
---------------	------------------------

A melted fusible link is identified by discolouration and swelling of its cover.

Important:

- The wiring of the front mover should be checked every year at your dealers to avoid electrical fires.
- Damaged wire covers should be mended with insulation tape immediately.

- *When a wire harness has come off its clamp, it should be re-clamped immediately.*

5. ADJUSTMENT OF HYDRAULIC SYSTEM PARTS

When hydraulic system parts such as the HST unit, power-steering unit, hydraulic pump, control valve, hydraulic cylinder, piping, etc., consult your ISEKI dealers. Users are advised not to adjust or repair hydraulic system parts by themselves.

VII. LUBRICATION CHART

FILLING DIAGRAM

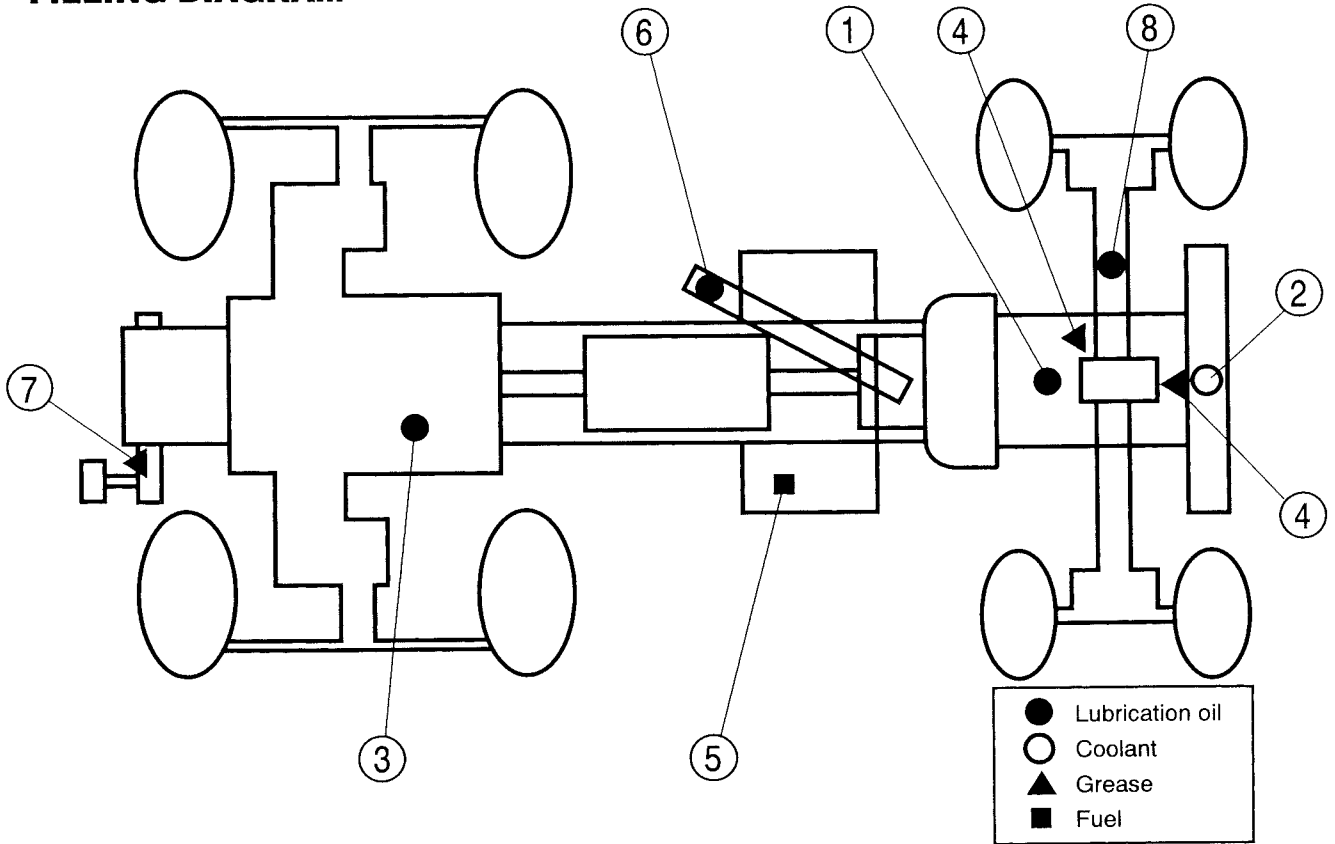

Ref. No.	Filling points	Lubricants	Quantity: liter (IMP gal.)
1	Engine	Engine oil	3.2 (0.7)
2	Radiator	Coolant (Soft water + antifreeze)	5.3 (1.2)
3	Transmission case	HST oil (SHELLDONAX TD)	11.0 (2.4)
4	Center pivot(2 points)	Grease	As required
5	Fuel tank	Diesel fuel	40.0 (8.8)
6	Reduction gear case	Gear oil (SAE80)	0.8 (0.17)
7	Clutch arm	Grease	As required
8	Rear axle	Gear oil (SAE 80)	4.1 (0.9)
	Other lubrication points marked with yellow paint	Gear oil or grease	As required

- Use oil of better than class CC.
- Use ISEKI's recommended oil.

VIII. PERIODICAL INSPECTION TABLE

VIII. PERIODICAL INSPECTION TABLE

○ : Inspection, replenishment, and adjustment
● : Replacement

△ : Cleaning and washing
★ : Consult your dealer.

Check points	Pre-operation	Inspection and servicing intervals hours of operation								Intervals after that	Judgement criteria
		50	100	150	200	250	300	350	400		
Engine oil	○	●		●		●		●		Replace after initial 50 h and then every 100 h.	Maintain the specified level.
Air cleaner			△		△		△		△	Clean after every 100 h.	
Radiator coolant	○									Replace every year.	Fill up to radiator throat.
Radiator	△										There should be no clogging.
Fuel	○										Keep fuel tank always full.
Fuel strainer	○		○		○		●			Replace after every 300 h.	There should be no dust in filter.
Fan belt	○										10 mm (0.4 in.) deflection
Electrolyte level		○	○	○	○	○	○	○	○		Level should be kept properly.
Engine oil filter							●			Replace after every 300 h.	
Transmission oil	○	●				●				Replace after initial 50 h. and then after every 200 h.	
Transmission oil filter		●				●				Replace after initial 50 h. and then replace after every 200 h.	
Suction filter		△				△				Clean after initial 50 h. and then clean after every 200 h.	
Clutch pedal play	○										20 to 25 mm (0.8 to 1.0 in.)
Brake pedal play	○										20 to 30 mm (0.8 to 1.2 in.)
Steering wheel	○										There should be no abnormality.
Tyre pressure	○										Front: 1.4 kgf/cm ² (20 psi) Rear: 1.6 kgf/cm ² (23 psi)
Toe-in							★				0 to 10 mm (0 to 0.4 in.)
Wheel tightening bolts	○										There should be no loose bolts.
Reduction gear case		●							●	Replace after initial 50 h and then every 300 h.	Maintain the specified level.
Rear axle oil		●							●	Replace after initial 50 h and then every 300 h.	Maintain the specified level.
Grease-up		○	○	○	○	○	○	○	○		
Radiator screen	△										There should be no clogging.
Radiator	△										There should be no clogging.
Electrical apparatus	○										All should work properly.
Air intake opening	△										There should be no clogging.

IX. TROUBLESHOOTING

1. ENGINE

Troubles	Presumable causes	Remedies
<ul style="list-style-type: none"> • Starter motor does not work. 	<ul style="list-style-type: none"> • Clutch pedal is not depressed. • PTO lever is not in neutral position. • Defective safety switch of seat • Battery is not charged fully. • Battery terminals are poorly connected. • Defective internal wiring in connector • Broken starter switch • Broken starter motor 	<ul style="list-style-type: none"> • Depress it fully. • Shift it to neutral position. • Consult your dealers. • Charge it. • Clean the terminal posts and connect them securely. • Rewire. • Consult your dealers. • Consult your dealers.
<ul style="list-style-type: none"> • Starter motor works but engine does not start. 	<ul style="list-style-type: none"> • No fuel • Water trapped in fuel • Air trapped in fuel • Clogged fuel pipes • Clogged fuel strainer • Slow cranking speed • Insufficient pre-heating • Throttle lever is in low speed position. • Too high engine oil viscosity • Clogged air-cleaner • Insufficient compression • Incorrect injection timing • Clogged injection nozzles 	<ul style="list-style-type: none"> • Replenish with fuel. • Drain trapped water from fuel strainer. • Bleed injection pump. • Clean fuel pipe inside. • Clean it. • Charge battery. • Preheat for specified time. • Turn it to high speed position. • Replace it with one of lower viscosity. • Clean it. • Consult your dealers. • Consult your dealers. • Consult your dealers.
<ul style="list-style-type: none"> • Engine runs at irregular speeds or stalls unintentionally. 	<ul style="list-style-type: none"> • Air trapped in fuel system • Improper earth • Clogged fuel strainer • Clogged air cleaner • Defective injection pump • Leaking fuel system 	<ul style="list-style-type: none"> • Locate cause of air-trapping and bleed system of air. • Polish earthing points and re-connect. • Clean it. • Clean element. • Consult your dealers. • Tighten joints securely or replace damaged pipe.
<ul style="list-style-type: none"> • Engine knocks. 	<ul style="list-style-type: none"> • Too low engine oil level • Engine is overheated. 	<ul style="list-style-type: none"> • Add oil. • Consult your dealers.

IX. TROUBLESHOOTING

Troubles	Presumable causes	Remedies
<ul style="list-style-type: none"> • Engine knocks. 	<ul style="list-style-type: none"> • Coolant temperature does not rise. • Defective injection pump • Incorrect valve clearances • Defective injection nozzles 	<ul style="list-style-type: none"> • Consult your dealers. • Consult your dealers. • Consult your dealers. • Consult your dealers.
<ul style="list-style-type: none"> • Engine output is insufficient. 	<ul style="list-style-type: none"> • No fuel • Clogged air cleaner • Engine is overloaded. • Improper fuel • Engine is overheated. • Defective injection nozzles • Insufficient compression • Improper valve clearances • Defective injection pump • Defective injection nozzles • Incorrect injection timing • Throttle lever is not in the high speed position. 	<ul style="list-style-type: none"> • Supply with fuel. • Clean element. • Decrease load or slow down tractor. • Use proper diesel fuel. • Cool down engine. • Consult your dealers. • Consult your dealers. • Consult your dealers. • Consult your dealers. • Consult your dealers. • Consult your dealers. • Shift it there securely.
<ul style="list-style-type: none"> • Engine is overheated. 	<ul style="list-style-type: none"> • Low engine coolant level • Loose fan belt • Clogged radiator and screen • Low engine oil level • Clogged air-intake openings • Engine is overloaded. • Burnt out coolant temperature warning lamp • Clogged engine oil filter 	<ul style="list-style-type: none"> • Replenish. • Tighten it properly. • Clean them. • Check level and add oil if necessary. • Clean air-intake screens. • Decrease load or slow down tractor. • Consult your dealers. • Replace it with a new one.
<ul style="list-style-type: none"> • Oil pressure lamp is blinking 	<ul style="list-style-type: none"> • Low engine oil level • Low engine oil viscosity • Clogged engine oil filter • Defective oil pump • Defective oil pressure switch 	<ul style="list-style-type: none"> • Add oil to specified level. • Replace with oil of higher viscosity. • Replace filter cartridge. • Consult your dealers. • Consult your dealers.
<ul style="list-style-type: none"> • Exhaust fumes are white. 	<ul style="list-style-type: none"> • Clogged air cleaner • Too high engine oil level • Insufficient fuel injection 	<ul style="list-style-type: none"> • Clean element. • Adjust oil level. • Consult your dealers.

SF303 & SF333

Troubles	Presumable causes	Remedies
<ul style="list-style-type: none"> • Exhaust fumes are black. 	<ul style="list-style-type: none"> • Defective fuel • Clogged intake and exhaust lines • Excessive fuel injection rate • Low injection nozzle pressure • Incorrect injection timing 	<ul style="list-style-type: none"> • Use proper fuel. • Clean air cleaner, or check muffler for clogging. • Consult your dealers. • Consult your dealers. • Consult your dealers.
<ul style="list-style-type: none"> • Engine stalls at low speed. 	<ul style="list-style-type: none"> • Defective injection pump • Incorrect valve clearance • Defective injection nozzles 	<ul style="list-style-type: none"> • Consult your dealers. • Consult your dealers. • Consult your dealers.
<ul style="list-style-type: none"> • Engine races. 	<ul style="list-style-type: none"> • Clogged governor • Engine oil leaks into cylinder. 	<ul style="list-style-type: none"> • Consult your dealers. • Consult your dealers.
<ul style="list-style-type: none"> • Excessive fuel consumption 	<ul style="list-style-type: none"> • Defective fuel • Clogged air-intake line • Engine is overloaded. • Fuel leaks • Incorrect valve clearances • Engine is over cooled. 	<ul style="list-style-type: none"> • Use proper fuel. • Check air cleaner and air-intake hose for clogging. • Decrease load. • Check fuel line for leaks. • Consult your dealers. • Consult your dealers.
<ul style="list-style-type: none"> • Charge lamp is blinking. 	<ul style="list-style-type: none"> • Defective wiring • Lower electrolyte level • Loose fan belt • Defective alternator • Defective regulator 	<ul style="list-style-type: none"> • Check wiring. • Adjust level. • Tighten it properly. • Consult your dealers. • Consult your dealers.

2. CLUTCH SYSTEM

<ul style="list-style-type: none"> • Clutch slips. 	<ul style="list-style-type: none"> • Incorrect clutch pedal adjustment • Worn clutch lining • Burnt clutch lining 	<ul style="list-style-type: none"> • Correct pedal play. • Consult your dealers. • Consult your dealers.
<ul style="list-style-type: none"> • Clutch does not disengage. 	<ul style="list-style-type: none"> • Seized clutch lining • Incorrect clutch pedal adjustment 	<ul style="list-style-type: none"> • Consult your dealers. • Correct pedal play.

3. BRAKE SYSTEM

<ul style="list-style-type: none"> • Defective braking effect or uneven braking 	<ul style="list-style-type: none"> • Excessive master brake pedal play • Worn brake linings • Improperly adjusted brake rods 	<ul style="list-style-type: none"> • Correct pedal play. • Consult your dealers. • Correct rod length.
---	---	---

IX. TROUBLESHOOTING

Troubles	Presumable causes	Remedies
<ul style="list-style-type: none"> • Master brake pedal does not return smoothly. 	<ul style="list-style-type: none"> • Fatigued or broken return spring • Defective lubrication of linkage 	<ul style="list-style-type: none"> • Replace it. • Lubricate lubrication points.
4. LIFT SYSTEM		
<ul style="list-style-type: none"> • Lift does not rise. 	<ul style="list-style-type: none"> • Low transmission oil level • Air trapped inside hydraulic piping • Clogged oil filter • Clogged suction oil filter • Defective hydraulic pump • Defective control valve • PTO lever is in high speed position. • Defective hydraulic cylinder 	<ul style="list-style-type: none"> • Fill up to upper limit. • Tighten joints securely. • Replace cracked pipes • Replace damaged O-rings. • Replace oil filter. • Clean it. • Consult your dealers. • Consult your dealers. • Shift it to neutral position. • Consult your dealers.
<ul style="list-style-type: none"> • Lift does not lower. 	<ul style="list-style-type: none"> • Lift lock is engaged. • Defective control valve • Seized lift shaft 	<ul style="list-style-type: none"> • Release it. • Consult your dealers. • Consult your dealers.
5. STEERING SYSTEM		
<ul style="list-style-type: none"> • Steering wheel is very heavy to turn. 	<ul style="list-style-type: none"> • Low tyre pressure • Low transmission oil level • Air trapped inside hydraulic piping • Clogged oil filter • Clogged suction oil filter • Defective hydraulic pump • Defective power-steering unit 	<ul style="list-style-type: none"> • Correct it as specified. • Fill up to upper limit. • Tighten joints securely. • Replace cracked pipes. • Replace damaged O-rings. • Replace oil filter. • Clean it. • Consult your dealers. • Consult your dealers.
<ul style="list-style-type: none"> • Steering wheel has an tendency to turn in one direction. 	<ul style="list-style-type: none"> • Uneven tire inflation • Improper toe-in • Worn tie-rod ends 	<ul style="list-style-type: none"> • Inflate both front and rear tyres to specified pressure. • Correct it. • Replace tie-rod.
<ul style="list-style-type: none"> • Excessive steering wheel play 	<ul style="list-style-type: none"> • Worn steering wheel column shaft • Defective power-steering unit • Worn tie-rod ends 	<ul style="list-style-type: none"> • Consult your dealers. • Consult your dealers. • Replace tie-rod.

SF303 & SF333

Troubles	Presumable causes	Remedies
6. HST (Hydrostatic transmission)		
<ul style="list-style-type: none"> • Tractor does not start travelling. 	<ul style="list-style-type: none"> • Parking brake is applied. • Too low engine speed • Low transmission oil level • Air trapped inside hydraulic piping • Clogged oil filter • Clogged suction oil filter • Defective HST unit • Improperly adjusted HST pedals 	<ul style="list-style-type: none"> • Release it. • Accelerate engine. • Fill to upper limit. • Tighten joints securely. • Replace cracked pipes • Replace damaged O-rings. • Replace oil filter. • Clean it. • Consult your dealers. • Adjust HST rod length.
<ul style="list-style-type: none"> • Tractor creeps without HST pedal being operated. 	<ul style="list-style-type: none"> • Incorrect neutral point of HST • Improperly positioned neutral arm • Stuck neutral arm • Defective HST unit 	<ul style="list-style-type: none"> • Adjust trunnion arm angle. • Adjust neutral arm position. • Lubricate. • Consult your dealers.
7. ELECTRICAL ACCESSORIES		
<ul style="list-style-type: none"> • Battery is not charged. 	<ul style="list-style-type: none"> • Melted fusible link • Defective wiring • Loose fan belt • Defective alternator • Defective regulator • Defective battery 	<ul style="list-style-type: none"> • Locate and repair cause of trouble, and install new fusible link. • Check wiring for loose terminals and earth, and short circuit. Repair defective parts. • Tighten belt as specified. • Consult your dealers. • Consult your dealers. • Correct loose terminals, corroded parts, and electrolyte level.
<ul style="list-style-type: none"> • Head lamps are dim. 	<ul style="list-style-type: none"> • Low battery capacity • Defective contact of switch or wiring 	<ul style="list-style-type: none"> • Charge battery. • Clean contact points and earthing point, and tighten them.
<ul style="list-style-type: none"> • Head lamps do not light up. 	<ul style="list-style-type: none"> • Burnt-out bulb • Blown fuse • Defective contact 	<ul style="list-style-type: none"> • Replace it. • Replace it. • Clean each contact and tighten securely.

IX. TROUBLESHOOTING

Troubles	Presumable causes	Remedies
<ul style="list-style-type: none">• Monitor lamps do not light up.	<ul style="list-style-type: none">• Defective contact	<ul style="list-style-type: none">• Re-connect connector.
<ul style="list-style-type: none">• Fuel pump does not work.	<ul style="list-style-type: none">• Blown fuse• Defective fuel pump	<ul style="list-style-type: none">• Replace it.• Consult your dealers.
<ul style="list-style-type: none">• Fuel cut-off solenoid does not work.	<ul style="list-style-type: none">• Blown fuse• Defective solenoid	<ul style="list-style-type: none">• Replace it.• Consult your dealers.

X. STORAGE

1. DAILY AND SHORT TERM STORAGE

- Clean the front mower.
- Top up the fuel tank to avoid rusting.
- Lower the mower on the ground.
- The tractor should be stored indoors if possible.
- When it has to be left outdoors, cover it with tarpaulin after heated components such as the engine, muffler, etc. have cooled down completely.
- When the ambient temperature is very low, remove the battery and store it in a warm shaded dry place. This will contribute greatly to easy starting of the engine the following morning.
- When the ambient temperature is likely to become lower than 0 °C (32°F), drain the engine coolant or add antifreeze to avoid engine breakdown due to frozen coolant.

Note:

- *When washing the tractor with pressurised water, be careful not to apply water directly to the electric apparatus, oil fillers, etc.*
- *Be sure to remove the main switch key to avoid electrical leakage.*

2. LONG TERM STORAGE

- Clean the front mower.
- Top up the fuel tank and close the fuel cock.
- Replace the engine oil with new and let the engine idle for about 5 minutes to lubricate every part sufficiently.
- Drain the engine coolant from the radiator and cylinder block and place an “empty radiator” tag on

the steering wheel.

- Lubricate all other parts.
- Grease up all greasing points.
- Re-tighten loose bolts and nuts.
- Inflate each tyre a little higher than specified.
- Dismount the mower or lower it to the ground.
- Place the tractor in a dry place protected from rainfall and cover it with tarpaulin after heated components such as the engine, muffler, etc. have cooled down completely.
- Remove the battery, charge it, adjust the electrolyte level, and store it in a shaded dry place with no access to children.
- Keep the clutch disengaged with the cut-off arm.
- Place wood under the tyres for protection.

Note:

- *Operate the engine at intermediate speeds for 5 minutes or so every month to prevent rusting. Remember to fill the radiator with coolant.*
- *Provide sufficient ventilation for exhaust fumes.*
- *When the battery is not dismantled from the tractor, be sure to disconnect the negative battery cable.*
- *Be sure to remove the starter key and keep it in a safe place.*

3. OPERATION AFTER A LONG TIME OF STORAGE

- Perform the pre-operation inspection without fail.
- Let the engine idle for about 30 minutes before applying any load, to ensure maximum engine performance and service life.
- Provide sufficient ventilation for exhaust fumes.

