

ISEKI



SW 521

ERSATZTEILLISTE
LISTE DE PIÈCES DE
RECHANGE



Directions for use of Parts Catalogue

1. Applicable model of machines

All component and option parts used for SW521 Mower are listed in this parts catalogue.

Description of type of machines and particulars

Type of Machines	Section	Engines		
		FC150V AB02 EB02	FC150V AB03 FB03 GB03	FC150V EB05
SW521	B	○		
	BE01	○		
	E01			○
	GB		○	
	GBE01		○	

Note: When you place an order for spare parts, please check and specify the Engine Model of your machine.

2. Explanation for head paragraph

KS00-101

KEY Réf.	PART CODE Pièces No.	DESCRIPTION	Désignation	QTY Quant.	TYPE OF MODEL			I T C	C O L	G R P	REMARKS Remarques
					FC150V AB03	FC150V FB03	FC150V GB03				
1	5130-702-077-XX	GUIDE	Guide	1	*	*	*				130702077
2	5510-012-214-XX	TANK-COMP-FUEL	Reservoir	1	*	*	*				510012214
3	5510-482-069-XX	CAP-ASSY-TANK	Ens. bouchon	1	*	*	*				510482069
4	5110-092-831-XX	GASKET	Joint	1	*	*	*				110092831
		BREATHER	Element	1	*						318292665600
			Element	1		*	*				491092054
				1	*	*	*				490192091
				1	*	*	*				490192094
				1	*	*	*				1316822
				1	*	*	*				10

- ① KEY shows the location of parts diagramed in the illustration.
- ② Parts numbers begin with `V` and `W` are standard parts of the market.
- ③ `LH` and `RH` on the parts name are described against the moving direction of the machine or are described on the condition how to install parts on the machines.

- ④ QTY shows the number of parts to be used for one unit of machine.
 `M` is indicated for parts supplied by a meter long.
 `ℓ` is indicated for parts supplied by liter.
 `AR` is indicated for parts need to be adjusted or regulated.
- ⑤ The following symbol classifies parts to be used for machines.
 `*` means standard parts.
 `T` shows that the parts can be installed as optional parts.
 `R` shows that the parts can be used as applicable parts to replace originally equipped parts.
- ⑥ Serial number : upper row shows the serial number for the first product and lower row for the last product.
 Example : Serial no. 1 through to serial no. 1999.
- ⑦ ITC : Interchangeability
 `1` ...OLD ← NEW
 New parts can be used in place of the old parts.
 `2` ...OLD → NEW
 Old parts can be used in place of the new parts.
 `3` ...OLD NEW
 Old parts and new parts can not be replaced each other.
- ⑧ COL : Color code
 Color is signified with color code number for colored parts.
 Please see the color list shown in the next page.
- ⑨ GRP : Parts shown in this column can be replaced by SET parts.
 Exsample : Parts marked Ⓐ can be replaced by parts marked Ⓑ, and Ⓓ for Ⓒ, so the rest follow in the same alphabetical order.
- ⑩ Remarks
 * Other maker's part code number is shown in this column.
 * When Fig. No. is shown in the Remark column of SET parts or ASSY parts, each of their component parts are listed in said Fig. No.

3. Color :

The following colors are used for color parts.

COLOR CODE	COLOR	SPRAY TYPE CODE NUMBER	PAINTS 4K DRUM	PAINTS 16K DRUM
7 F	MIRROR BLACK	1300-954-001-10	1300-954-003-00	1300-954-004-00
8 E	SILVER MIST	1300-968-001-10	1300-968-003-00	1300-968-004-00

NOTE : Color code is signified only for the parts assigned by the maker as color parts.

4. Serial Numbers :

- 1) For engines serial number is stamped on CRANKCASE – COMP.

Please see FC150V – AB02,EB02 Fig.No.1-17, 18, 41, FC150V – AB03,FB03,GB03 Fig. No.1-17, 18, 39, FC150V – EB05 Fig.No.1-17

- 2) For chassies serial number is shown on the LABEL.

Please see



5. Parts Order

- 1) Parts numbers listed in the parts catalogue are all registered in “ISEKI on-line computer”.
- 2) When you order parts, please make sure of correct numbers.
- 3) When substitute parts is available, the part number ordered will be automatically turned to a new part number.
- 4) Please be sure to use “ISEKI GENUINE PARTS”.

Any other similar parts other than ISEKI parts when used may cause a trouble that makes us unable to repair or guarantee the warrant.

MODE D'EMPLOI DE CE CATALOGUE

1. Machine concernée

Toutes les pièces et composants utilisés pour la tondeuse SW519 sont repris dans ce manuel.

Explication du modèle et particularités de la machine

Machine	Modèle	Deutsch	English	Nederlands	Français	Moteur
---------	--------	---------	---------	------------	----------	--------

2. Explication du tableau principal

- 1) Réf. n° : C'est un numéro de référence pour trouver les pièces dans les plans.
- 2) Pièces n° : Chaque pièce possède son propre numéro de code à 12 chiffres avec lequel elle peut être contrôlée par ordinateur. Les pièces comportant un "V" ou un "W" dans leur numéro de code en tête sont procurable sur le marché.
- 3) "Gauche" et "Droite" dans la désignation de pièce se repère selon la direction de marche avant de la machine ou explique comment monter la pièce sur la machine.
- 4) Quant. : Cette colonne spécifie les quantités d'une pièce requise pour chaque section donnée.

"M" est utilisé pour des pièces fournies au mètre.
 "l" est utilisé pour des pièces fournies au litre.
 "AR" signifie "suivant les besoins".
- 5) Les symboles suivants classifient les pièces utilisées sur la machine.

"*" indique des pièces standards.
 "T" indique des pièces pouvant être utilisées en option.
 "R" indique des pièces pouvant remplacer des pièces montées d'origine.
- 6) Numéro de série : la ligne supérieure indique le numéro série de la première machine, la ligne inférieure le numéro de série de la dernière machine montée avec la pièce concernée.
 Exemple : du n° de série 1 jusqu'au n° 1999.

7) ITC : Interchangeabilité

"1" : indique que la nouvelle pièce (modifiée) peut remplacer l'ancienne.

"2" : indique qu'une ancienne pièce peut remplacer la nouvelle pièce.

"3" : indique que l'ancienne et la nouvelle pièce ne sont pas interchangeable.

8) Col : Code couleur

Indique le numéro de code couleur pour les pièces peintes. Veuillez vous référer à la liste sur la page suivante.

9) GRP :

Indique que la pièce peut être remplacée par un kit de pièces.

Ex. : les pièces marquées par un B remplacent des pièces marquées d'un A, D remplace C, etc....

10) Remarques :

* N° des pièces utilisées par d'autres fabricants.

* Si le numéro de figure (fig. n°) suit des pièces reprises dans un kit ou dans un ensemble de pièces, les vues éclatées de ces pièces sont reprises sous la fig. mentionnée.

3. Peinture

Les peintures suivantes sont utilisées :

Code couleur	Peinture	N° de code flacon spray	Peinture 4 kg	Peinture 16 kg
4 G	Crystal blue	1300-957-001-10	1300-957-003-00	1300-957-004-00
5 I	Sunset gray	1300-959-001-10	1300-959-003-00	1300-959-004-00
6 G	Summer white	1300-958-001-10	1300-958-003-00	1300-958-004-00
7 F	Mirror black	1300-954-001-10	1300-954-003-00	1300-954-004-00

Note : ne s'applique que si la pièce est indiquée comme étant peinte par le fabricant.

4. Numéro de série

- 1) Le numéro moteur est estampé sur le bloc moteur.
Réf. fig. n° 5-1.
- 2) Le numéro de châssis est indiqué sur l'étiquette.
Réf.

5. Commande de pièces

- 1) Les numéros des pièces indiqués dans le catalogue de pièces sont repris dans "l'ordinateur en ligne" d'Iseki.
- 2) Veuillez vous assurer que les numéros des pièces commandées sont exacts.
- 3) Si une pièce a été substituée, le numéro de pièce est automatiquement remplacé par le nouveau numéro.
- 4) Utilisez des pièces d'origine Iseki. Toutes autres pièces utilisées semblables mais différentes des pièces Iseki peuvent causer une anomalie que nous ne pourrions plus réparer ou garantir.

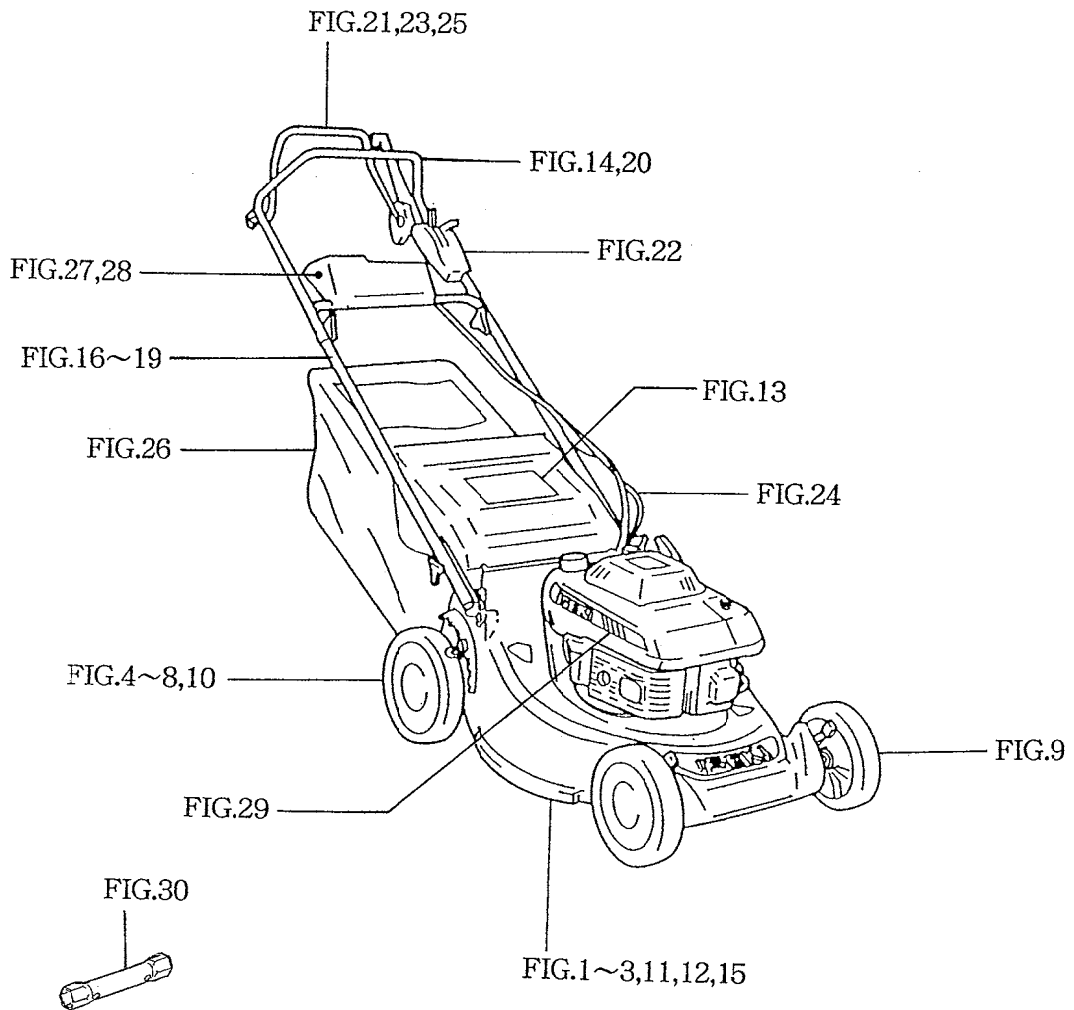

CONTENTS

ENGINE (FC150V – AB02,EB02)

Moteur

CYLINDER/CRANKCASE	Fig. 1
Cylindre/Carter	
PISTON/CRANKSHAFT	Fig. 2
Piston/Vilebrequin	
VALVE/CRANKSHAFT	Fig. 3
Soupape/Arbre a cames	
LUBRICATION – EQUIPMENT	Fig. 4
Lubrification	
COOLING – EQUIPMENT	Fig. 5
Refroidissement	
ELECTRIC – EQUIPMENT	Fig. 6
Électricité	
CONTROL – EQUIPMENT	Fig. 7
Commandes	
CARBURETOR (EB02)	Fig. 8
Carburateur	
CARBURETOR (AB02)	Fig. 9
Carburateur	
AIR – FILTER/MUFFLER	Fig. 10
Filtre à air/Echappement	
FUEL – TANK/FUEL – VALVE	Fig. 11
Resservoir/Robinet à carburant	
STARTER	Fig. 12
Démarreur	
LABEL	Fig. 13
Étiquette	
ACCESSORY	Fig. 14
Accessoire	

CONTENTS

ENGINE (FC150V – AB03,FB03,GB03)

Moteur

CYLINDER/CRANKCASE	Fig. 1
Cylindre/Carter	
PISTON/CRANKSHAFT	Fig. 2
Piston/Vilebrequin	
VALVE/CRANKSHAFT	Fig. 3
Soupape/Arbre à cames	
LUBRICATION – EQUIPMENT	Fig. 4
Lubrification	
COOLING – EQUIPMENT	Fig. 5
Refroidissement	
ELECTRIC – EQUIPMENT	Fig. 6
Électricité	
CONTROL – EQUIPMENT	Fig. 7
Commandes	
CARBURETOR	Fig. 8
Carburateur	
CARBURETOR (AB03)	Fig. 9
Carburateur	
AIR – FILTER/MUFFLER	Fig. 10
Filtre à air/Echappement	
FUEL – TANK/FUEL – VALVE	Fig. 11
Reservoir/Roînet à carburant	
RECOIL STARTER	Fig. 12
Lanceur	
ELECTRIC STARTER	Fig. 13
Démarrreur	
ELECTRIC STARTER (AB03)	Fig. 14
Démarrreur	
LABEL	Fig. 15
Étiquette	
ACCESSORY	Fig. 16
Accessoire	

CONTENTS

ENGINE (FC150V – EB05)

Moteur

CYLINDER/CRANKCASE	Fig. 1
Cylindre/Carter	
PISTON/CRANKSHAFT	Fig. 2
Piston/Vilebrequin	
VALVE/CAMSHAFT	Fig. 3
Soupape/Arbre à cames	
LUBRICATION – EQUIPMENT	Fig. 4
Lubrification	
COOLING – EQUIPMENT	Fig. 5
Refroidissement	
ELECTRIC – EQUIPMENT	Fig. 6
Électricité	
CONTROL – EQUIPMENT	Fig. 7
Commandes	
CARBURETOR	Fig. 8
Carburateur	
AIR – FILTER/MUFFLER	Fig. 9
Filtre à air/Echappement	
FUEL – TANK/FUEL – VALVE	Fig. 10
Reservoir/Robinet à carburant	
STARTER	Fig. 11
Démarreur	
BRAKE/COVER	Fig. 12
Plaque (modele R)	
LABEL	Fig. 13
Étiquette	
ACCESSORY	Fig. 14
Accessoire	

CONTENTS

CHASSIS

ENGINE/BRAKE SYSTEM	Fig. 1
Système de freinage	
B.B.C SYSTEM (B TYPE)	Fig. 2
Système de frein de lame (modèle B)	
BLADE SYSTEM	Fig. 3
Lame	
JOINT SYSTEM	Fig. 4
Cardane	
CASE/MISSION SYSTEM	Fig. 5
Boitier de transmission	
GEAR SYSTEM	Fig. 6
Pignonnerie	
RACHET SYSTEM	Fig. 7
Cliquet	
WHEEL/REAR SYSTEM	Fig. 8
Roue arrière	
WHEEL/FRONT SYSTEM	Fig. 9
Roue avant	
JOINT SYSTEM	Fig. 10
Cardan	
DECK SYSTEM	Fig. 11
Carter de coupe	
DECK/FAN SYSTEM	Fig. 12
Carter de coupe	
COVER/DISCHARGE SYSTEM	Fig. 13
Deflecteur	
HANDLE SYSTEM (B TYPE)	Fig. 14
Mancheron (modèle B)	
HANDLE/BRACKET SYSTEM	Fig. 15
Mancheron	
HANDLE/BRACKET SYSTEM (EXCEPT G TYPE)	Fig. 16
Mancheron (excepté modèle G)	
BRACKET/BATTERY SYSTEM (G TYPE)	Fig. 17
Support/batterie (modèle G)	
HANDLE/BRACKET SYSTEM (E01 TYPE)	Fig. 18
Mancheron (modèle E01)	

HANDLE/BRACKET SYSTEM (G TYPE).....	Fig. 19
Mancheron (modèle G)	
HANDLE SYSTEM (E01 TYPE)	Fig. 20
Mancheron (modèle E01)	
LEVER SYSTEM (B TYPE).....	Fig. 21
Levier (modèle B)	
CONTROL LEVER SYSTEM	Fig. 22
Levier de contrôle	
LEVER SYSTEM (E01 TYPE)	Fig. 23
Levier (modèle E01)	
CABLE SYSTEM.....	Fig. 24
Câble	
LEVER SYSTEM (B TYPE).....	Fig. 25
Levier (modèle B)	
COLLECTOR SYSTEM.....	Fig. 26
Collecteur	
HARNESS, BATTERY SYSTEM (G TYPE)	Fig. 27
Faisceau/batterie (modèle G)	
HARNESS/BATTERY SYSTEM (GB TYPE)	Fig. 28
Faisceau/batterie (modèle GB)	
MARK, ORNAMENT, LABEL SYSTEM	Fig. 29
Etiquettes	
TOOLS, MANUAL SYSTEM	Fig. 30
Outils/manuel	

ENGINE

Moteur

FC150V – AB02
FC150V – EB02

FIG. 1 CYLINDER/CRANKCASE
Cylinder/Carter

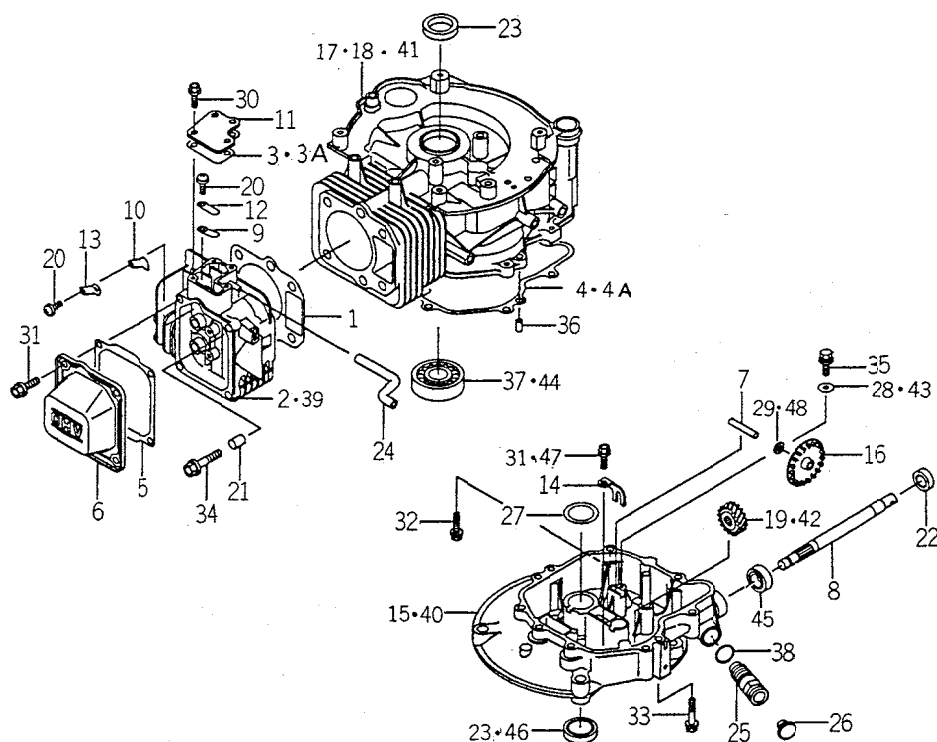

K621-3010

KEY Réf.	PART CODE Pièces N ^o	DESCRIPTION	Désignation	QTY Quant.	TYPE OF MODEL		Modél	I T C	C O L	G R P	REMARKS Remarques
					FC150V ABC2	FC150V EB02					
1	5110-042-099-XX	GASKET HEAD	Joint de cylindre	1	*	*					110042099
2	5110-086-023-XX	HEAD-COMP-CYLINDER	Culasse	1		*					110086023
3	5110-092-740-XX	GASKET-COVER	Joint	1	*	1- -C25867					110092740
3A	5110-602-007-XX	GASKET-COVER	Joint	1		C25868-					110602007
4	5110-092-770-XX	GASKET-CRANKCASE	Joint	1	*	1- -C25867					110092770
4A	5110-602-011-XX	GASKET-CRANKCASE	Joint	1		C25868-					110602011
5	5110-092-848-XX	GASKET-ROCKER	Joint	1	*	*					110092848
6	5110-222-057-XX	CASE-ROCKER	Joint	1	*	*					110222057
7	5131-072-202-XX	SHAFT	Arbre	1	*	*					131072202
8	5131-072-220-XX	SHAFT	Arbre	1	*	*					131072220
9	5131-832-258-XX	PLATE	Praque	1	*	*					131832258
10	5131-832-259-XX	PLATE	Praque	1	*	*					131832259
11	5140-242-180-XX	COVER	Capot	1	*	*					140242180
12	5161-262-149-XX	VALVE	Soupape	1	*	*					161262149
13	5161-262-150-XX	VALVE	Soupape	1	*	*					161262150
14	5210-832-062-XX	ARM	Bras	1	*	*					210832062
15	5490-156-088-XX	COVER-CRANKCASE	Carter	1		*					490156088
16	5490-732-055-XX	SLINGER-OIL	Défecteur d'huile	1	*	*					490732055
17	5491-202-240-XX	CRANKCASE-COMP	Carter	1		*					491202240
18	5491-202-246-XX	CRANKCASE-COMP	Carter	1		*					491202246
19	5590-562-790-XX	GEAR-HELICAL	Pignon	1		*					590562790
20	5920-092-166-XX	SCREW-5X8	Vis	2	*	*					920092166
21	5920-431-264-XX	PIN	Axe	2	*	*					920431264
22	5920-492-204-XX	SEAL-OIL	Joint SPI	1		*					920492204
23	5920-492-208-XX	SEAL-OIL	Joint SPI	2		*					920492208

FIG. 1 CYLINDER/CRANKCASE
Cylindre/Carter

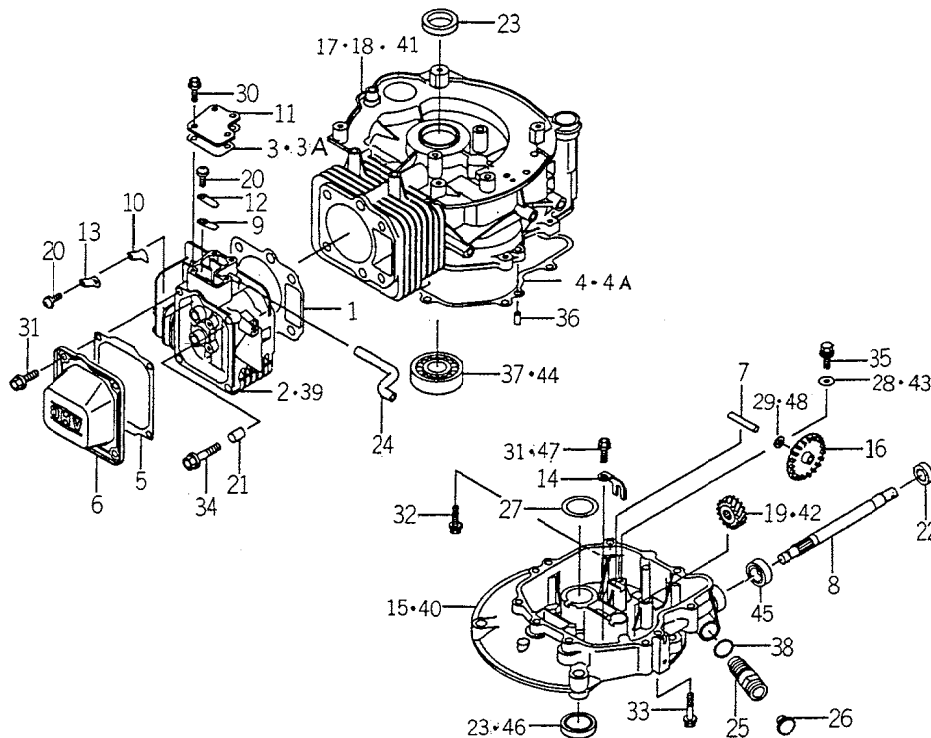

K621-0010

KEY Réf.	PART CODE Pièces No.	DESCRIPTION	Designation	QTY Quant.	TYPE OF MODEL			I T C	C O L	G R P	REMARKS Remarques
					FC150V AB02	FC150V EB02	Model				
24	5920-592-256-XX	TUBE	Tuyau	1	*	*					920592256
25	5920-662-180-XX	PLUG	Bouchon	1	*	*					920662180
26	5920-662-193-XX	PLUG	Bouchon	1		*					920662193
27	5922-002-026-XX	WASHER-25X42X1.0	Rondelle	1		*					922002026
28	5922-002-033-XX	WASHER-5X16X0.8	Rondelle	1		*					922002033
29	5922-002-034-XX	WASHER-6X12X1.6	Rondelle	1		*					922002034
30	5130-B05-10X-XX	BOLT-FLANGED	Vis	4	*	*					130B0510
31	5130-B06-12X-XX	BOLT-FLANGED	Vis	5	*	*					130B0612
32	5130-G06-25X-XX	BOLT-FLANGED	Vis	5	*	*					130G0625
33	5130-G06-45X-XX	BOLT-FLANGED	Vis	2	*	*					130G0645
34	5130-G08-45X-XX	BOLT-FLANGED	Vis	4	*	*					130G0845
35	5187-B05-10X-XX	BOLT-UPSET-WSP	Vis	1	*	*					187B0510
36	5551-A06-12X-XX	PIN-DOWEL	Pion	2	*	*					551A0612
37	5601-862-05X-XX	BEARING-BALL	Roulement à billes	1		*					601B6205
38	5670-D20-15X-XX	O-RING	Joint torique	1	*	*					670D2015
39	5110-086-008-XX	HEAD-COMP-CYLINDER	Culasse	1	*						110086008
40	5490-156-055-XX	COVER-CRANKCASE	Carter	1	*						490156055
41	5491-202-184-XX	CRANKCASE-COMP	Carter	1	*						491202184
42	5590-562-790-XX	GEAR-HELICAL	Pignon	1	*						590562790
43	5145-V17-281-AX	WASHER	Rondelle	1	*						3145V17281A
44	5920-452-155-XX	BEARING-BALL	Roulement à billes	1	*						920452155
45	5117-604-241-00	SEAL-OIL	Joint SPI	1	*						311760424100
46	5158-014-231-AX	SEAL-OIL	Joint SPI	2	*						3158014231A
47	5130-B06-14X-XX	BOLT-FLANGED	Vis	1	*						130B0614
48	5920-222-131-XX	WASHER	Rondelle	1	*						920222131

FIG. 6 ELECTRIC – EQUIPMENT

Électricité

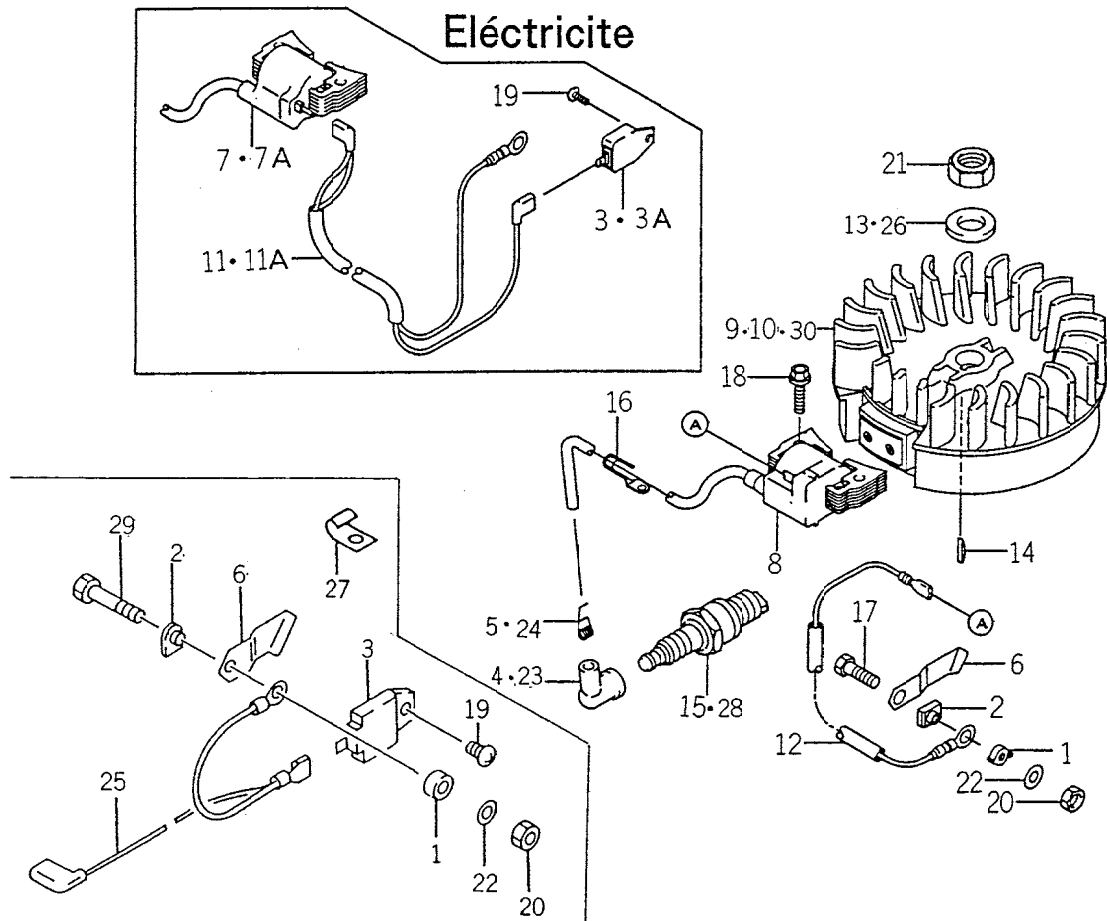

K621-7060

KEY Réf.	PART CODE Pièces No.	DESCRIPTION	Désignation	QTY Quant.	TYPE OF MODEL			I T C	C O L	G R P	REMARKS Remarques
					FC150V AB02	FC150V EB02	Modél				
1	5140-242-183-XX	COVER	Capot	1	*	*					140242183
2	5160-732-124-XX	INSULATOR	Ecran thermique	1	*	*					160732124
3	5211-192-119-XX	IGNITER	Bougie d'allumage	1	*	1- B50811					211192119
3A	5211-192-139-XX	IGNITER	Bougie d'allumage	1		B50812-					211192139
4	5211-302-066-XX	CAP-SPARK PLUG	Capuchon	1		*					211302066
5	5211-692-004-XX	TERMINAL	Borne	1		*					211692004
6	5211-692-066-XX	TERMINAL	Borne	1	*	*					211692066
7	5211-712-153-XX	COIL-ASSY-IGNITION	Ens. bobine d'allumage	1	*	1- B50811					211712153
7A	5211-712-176-XX	COIL-ASSY-IGNITION	Ens. bobine d'allumage	1		B50812-					211712176
8	5211-712-200-XX	COIL-ASSY-IGNITION	Ens. bobine d'allumage	1		*					211712200
9	5211-942-218-XX	FLYWHEEL-COMP	Volant	1		*					211942218
10	5211-942-290-XX	FLYWHEEL-COMP	Volant	1		*					211942290
11	5260-112-246-XX	WIRE-LEAD	Fil	1		1- C13447					260112246
11A	5260-112-279-XX	WIRE-LEAD	Fil	1		C13448-					260112279
12	5260-112-306-XX	WIRE-LEAD	Fil	1		*					260112306
13	5920-222-102-XX	WASHER	Rondelle	1		*					920222102
14	5920-382-077-XX	KEY	Clavette	1	*	*					920382077
15	5920-702-084-XX	PLUG-SPARK-BP6ES	Bougie	1		*					920702084
16	5921-702-041-XX	CLAMP	Attache	1		*					921702041
17	5112-B05-22X-XX	BOLT-UPSET	Vis	1		*					112B0522
18	5130-606-25X-XX	BOLT-FLANGED	Vis	2	*	*					13060625
19	5241-B04-12X-XX	SCREW-PAN-WP	Vis	1	*	*					241B0412
20	5311-B05-00X-XX	NUT-HEX	Ecrou	1	*	*					311B0500
21	5314-G14-00X-XX	NUT-HEX-FINE	Ecrou	1	*	*					314G1400
22	5410-B05-00X-XX	W-PLAIN-S	Rondelle	1	*	*					410B0500

FIG. 7 CONTROL – EQUIPMENT

Commandes

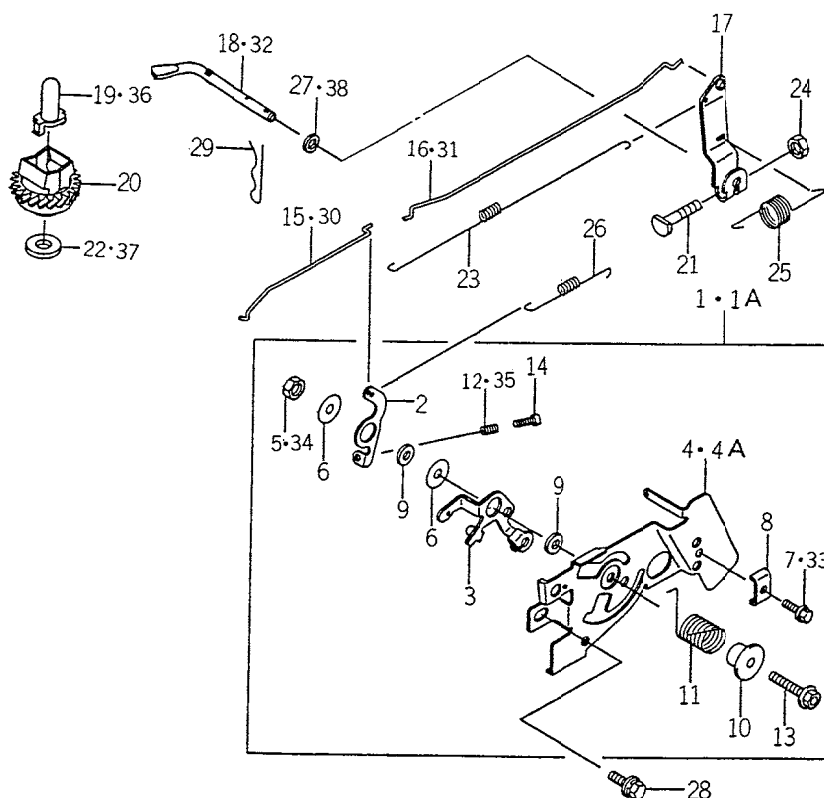

X621-0070

KEY Réf.	PART CODE Pièces N°	DESCRIPTION	Désignation	QTY Quant.	TYPE OF MODEL			I T C	C O L	G R P	REMARKS Remarques
					FC150V AB02	FC150V EB02	Modél				
1	5391-802-549-XX	PANEL-ASSY-CONTROL	Ens. panneau de commande	1	*	1- -F06974 F06975-					391802549
1A	5391-802-904-XX	PANEL-ASSY-CONTROL	Ens. panneau de commande	1							391802904
2	5131-682-283-XX	LEVER	Levier	1	*	*					131682288
3	5131-682-293-XX	LEVER	Levier	1	*	*					131682298
4	5592-262-201-XX	PANEL-CONTROL	Panneau de commande	1	*	1- -F06974 F06975-					592262201
4A	5592-262-293-XX	PANEL-CONTROL	Panneau de commande	1							592262293
5	5920-152-051-XX	NUT	Ecrou	1	*	*					920152051
6	5920-222-372-XX	WASHER-6X19X1.2	Rondelle	2	*	*					920222372
7	5921-502-182-XX	BOLT-5X18	Vis	1	*	*					921502182
8	5920-372-209-XX	CLAMP	Attache	1	*	*					920372209
9	5921-432-135-XX	COLLAR-6X13X2.3	Entretoise	2	*	*					921432135
10	5921-432-148-XX	COLLAR	Entretoise	1	*	*					921432148
11	5921-442-211-XX	SPRING	Ressort	1	*	*					921442211
12	5921-442-266-XX	SPRING	Ressort	1		*					921442266
13	5130-806-30X-XX	BOLT-FLANGED	Vis	1	*	*					13080630
14	5214-B04-20X-XX	SCREW-PAN	Vis	1	*	*					214B0420
15	5161-692-125-XX	LINK-CHOKE	Tige	1		*					161692125
16	5161-712-080-XX	LINK	Tige	1		*					161712080
17	5211-872-06C-XX	ARM-ASSY	Ens. bras	1	*	*					211872060
18	5390-032-071-XX	ARM-PIVOT	Bras	1		*					390032071
19	5420-362-051-XX	SLEEVE	Bague	1		*					420362051
20	5491-102-076-XX	GOVERNOR-ASSY	Ens. regulateur	1	*	*					491102076
21	5920-022-269-XX	BOLT	Vis	1	*	*					920022269
22	5920-222-019-XX	WASHER	Rondelle	1		*					920222019
23	5920-812-299-XX	SPRING-LINK	Ressort	1	*	*					920812299

FIG. 8 CARBURETOR (EB02)

Carburateur

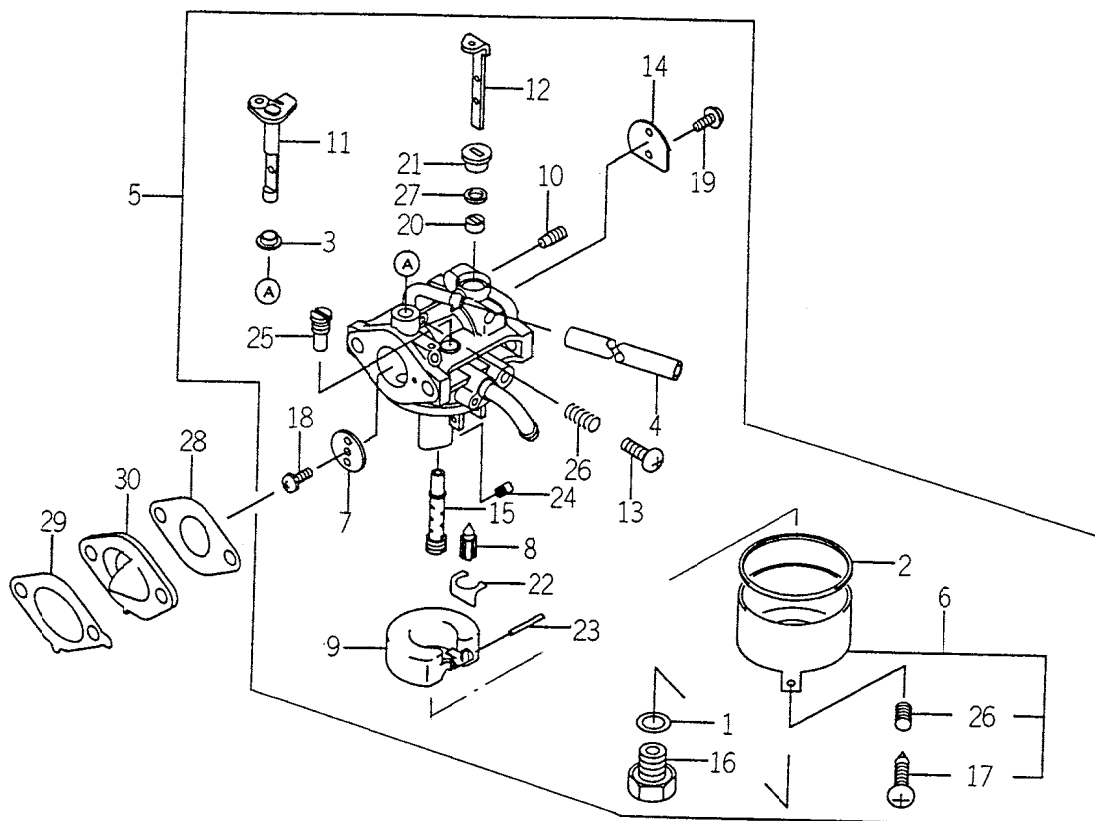

K621-0080

KEY Réf.	PART CODE Pièces N°	DESCRIPTION	Désignation	QTY Quant.	TYPE OF MODEL		Modél	I T C	C O L	G R P	REMARKS Remarques
					FC150V ABC2	FC150V EB02					
1	5110-092-036-XX	GASKET	Joint	1		*					110092036
2	5110-092-037-XX	GASKET	Joint	1		*					110092037
3	5921-432-143-XX	COLLAR	Entretoise	1		*					921432143
4	5921-902-163-XX	TUBE-4X7X125	Tuyau	1		*					921902163
5	5150-032-364-XX	CARBURETOR-ASSY	Ens. carburateur	1		*					150032364
6	5160-202-052-XX	CHAMBER-FLOAT	Chamber du flotteur	1		*					160202052
7	5160-252-001-XX	VALVE-THROTTLE 110	Boisseau	1		*					160252001
8	5160-302-083-XX	VALVE-FLOAT	Soupape	1		*					160302083
9	5160-312-058-XX	FLOAT	Flotteur	1		*					160312058
10	5160-352-063-XX	JET-AIR 0.9	Vis de richesse	1		*					160352063
11	5160-412-178-XX	SHAFT-CARBURETOR	Axe volet d'air	1		*					160412178
12	5160-412-197-XX	SHAFT-CARBURETOR	Axe volet d'air	1		*					160412197
13	5214-B04-12X-XX	SCREW-PAN	Vis	1		*					214B0412
14	5161-262-199-XX	VALVE	Volet d'air	1		*					161262199
15	5491-212-189-XX	NOZZLE-MAIN	Gicleur principal	1		*					491212189
16	5920-022-011-XX	BOLT	Vis	1		*					920022011
17	5920-092-015-XX	SCREW	Vis	1		*					920092015
18	5920-092-024-XX	SCREW	Vis	1		*					920092024
19	5920-092-149-XX	SCREW	Vis	2		*					920092149
20	5920-272-003-XX	COLLAR	Entretoise	1		*					920272003
21	5920-272-004-XX	COLLAR	Entretoise	1		*					920272004
22	5920-332-067-XX	RING-SNAP	Goupille à ressort	1		*					920332067
23	5920-432-006-XX	PIN	Axe	1		*					920432006
24	5920-632-096-XX	JET-MAIN 68.8	Gicleur principal	1		*					920632096
25	5920-642-002-XX	JET-PILOT 45	Vis de mélange	1		*					920642002

FIG. 9 CARBURETOR (AB02)

Carburateur

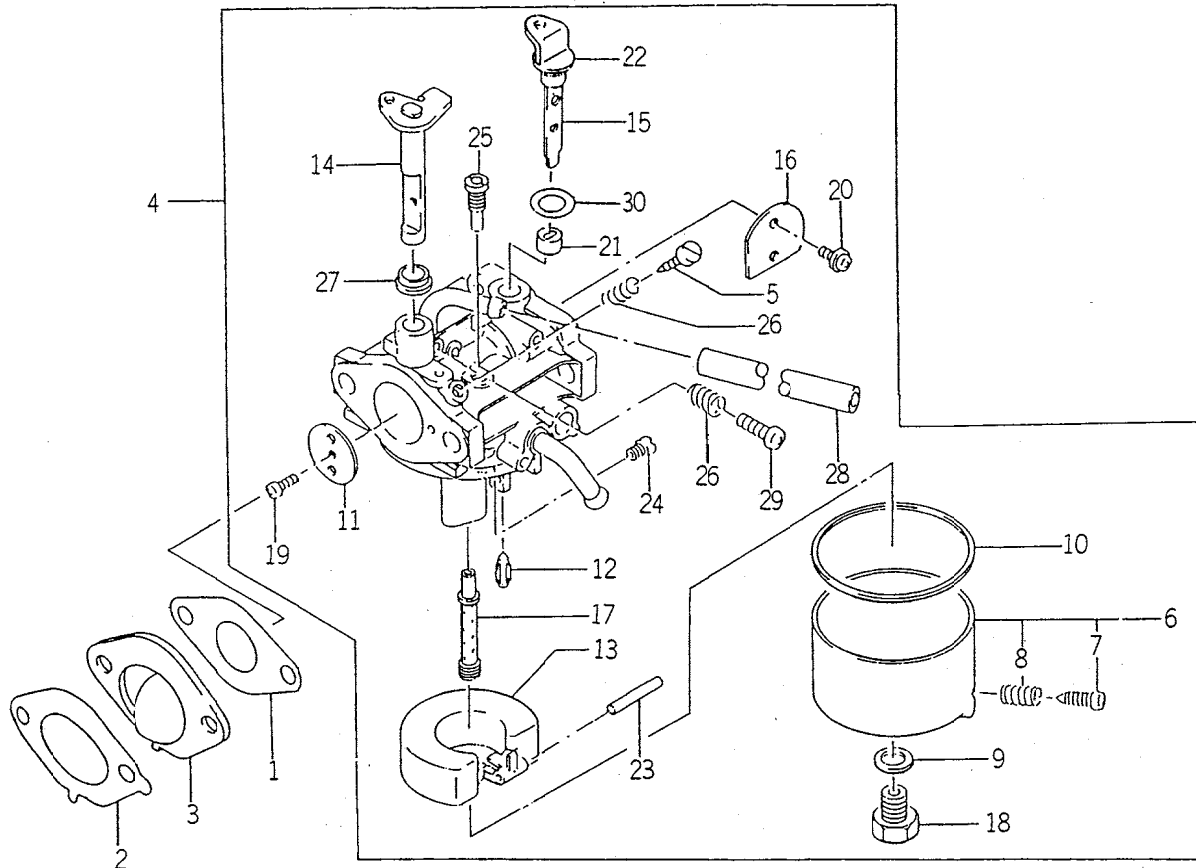

K500-101

KEY Réf.	PART CODE Pièces No.	DESCRIPTION	Désignation	QTY Quant.	TYPE OF MODEL			I T C	C O L	G R P	REMARKS Remarques
					FC150V ABC2	FC150V EBJ2	Modél				
1	5110-092-746-XX	GASKET, CARBURETOR	Joint	1	*						110092746
2	5110-092-833-XX	GASKET, INSULATOR	Joint	1	*						110092833
3	5160-732-135-XX	INSULATOR	Ecran thermique	1	*						160732136
4	5150-032-003-XX	CARBURETOR-ASSY.	Ens. carburateur	1	*						150032006
5	5164-706-114-00	SCREW-PILOT AIR	Vis	1	*						316470611400
6	5145-766-130-AX	CHAMBER-FLOAT	Chambre du flotteur	1	*						3145766130A
7	5154-706-133-AX	SCREW	Vis	1	*						3154706133A
8	5131-226-116-00	SPRING	Ressort	1	*						313122611600
9	5144-996-159-AX	GASKET	Joint	1	*						3144996159A
10	5145-986-128-AX	GASKET	Joint	1	*						3145986128A
11	5136-506-101-00	VALVE-THROTTLE, #110	Boisseau	1	*						313650610100
12	5144-996-122-AX	VALVE-FLOAT	Soupape	1	*						3144996122A
13	5160-312-058-XX	FLOAT	Flotteur	1	*						160312058
14	5160-412-178-XX	SHAFT-CARBURETOR, TH	Axe voletd'air	1	*						160412178
15	5160-412-197-XX	SHAFT-CARBURETOR, CH	Axe voletd'air	1	*						160412197
16	5161-262-173-XX	VALVE, CHOKE	Volet d'air	1	*						161262173
17	5491-212-113-XX	NOZZLE-MAIN, #2A	Gicleur principal	1	*						491212113
18	5144-996-143-AX	BOLT	Vis	1	*						3144996143A
19	5165-506-137-AX	SCREW	Vis	1	*						3165506137A
20	5920-092-149-XX	SCREW	Vis	2	*						920092149
21	5145-986-138-AX	COLLAR	Entretoise	1	*						3145986138A
22	5145-986-157-AX	COLLAR	Entretoise	1	*						3145986157A
23	5144-996-127-AX	PIN	Axe	1	*						3144996127A
24	5920-632-096-XX	JET-MAIN, #68, 8	Gicleur principal	1	*						920632096
25	5920-642-065-XX	JET-PILOT, #38, 8	Vis de melange	1	*						920642065

FIG. 10 AIR – FILTER/MUFFLER
Filter à air/Echappement

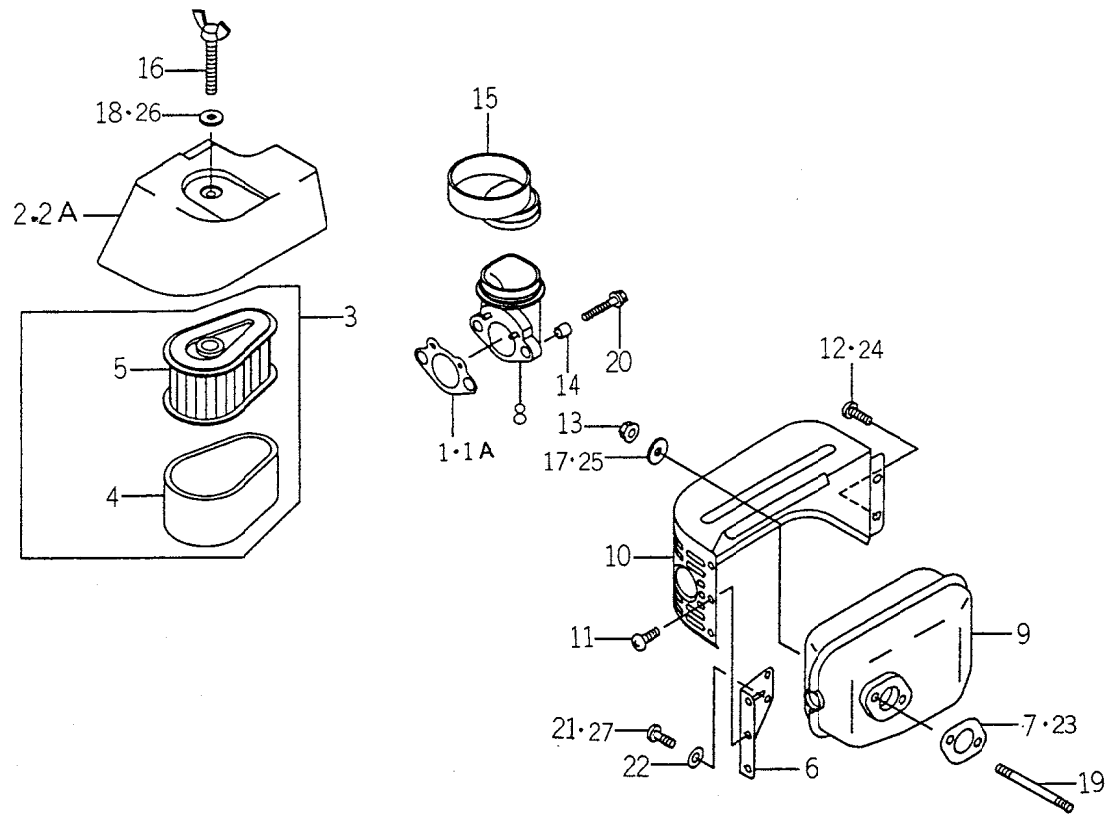

K621-0090

KEY Réf.	PART CODE Pièces No.	DESCRIPTION	Désignation	QTY Quant.	TYPE OF MODEL		Modél	I T C	C O L	G R P	REMARKS Remarques
					FC150V AB02	FC150V EB02					
1	5110-092-742-XX	GASKET-INTAKE PIPE	Joint	1	*	1-					110092742
1A	5110-602-067-XX	GASKET-INTAKE PIPE	Joint	1		-C25867 C25868-					110602067
2	5110-122-272-XX	CAP-AIR FILTER	Capuchon	1	*	1-					110122272
2A	5110-122-313-XX	CAP-AIR FILTER	Capuchon	1		-C26560 C26561-					110122313
3	5110-292-010X-X	ELEMENT-ASSY	Ens. element	1	*	*					110292302
4	5110-132-119-XX	ELEMENT-AIR FILTER	Element	1	*	*					110132119
5	5110-132-120-XX	ELEMENT-AIR FILTER	Element	1	*	*					110132120
6	5110-462-053-XX	BRACKET	Support	1	*	*					110462353
7	5110-602-009-XX	GASKET-MUFFLER	Joint	1		*					110602009
8	5160-602-129-XX	PIPE-INTAKE	Tubulure d'admission	1	*	*					160602129
9	5490-702-491-XX	MUFFLER-COMP	Echappement	1	*	*					490702491
10	5491-062-446-XX	COVER-MUFFLER	Couvercle	1	*	*					491062446
11	5920-092-166-XX	SCREW-5X8	Vis	3	*	*					920092166
12	5920-092-308-XX	SCREW	Vis	2		*					920092308
13	5920-151-193-XX	NUT	Ecrou	2	*	*					920151193
14	5920-262-272-XX	SPACER-6. 2X7. 8X8	Pièce d'écartement	2	*	*					920262272
15	5920-592-257-XX	TUBE	Tuyau	1	*	*					920592257
16	5921-502-101-XX	BOLT	Vis	1	*	*					921502101
17	5922-002-032-XX	WASHER-7X21X2. 3	Rondelle	2		*					922002032
18	5922-002-078-XX	WASHER-6. 5X18X2. 0	Rondelle	1		*					922002078
19	5172-606-80X-XX	BOLT-STUD	Goujon	2	*	*					17260630
20	5186-B06-80X-XX	BOLT-UPSET-WP	Vis	2	*	*					186B0630
21	5214-805-10X-XX	SCREW-PAN	Vis	2		*					214B0510
22	5411-805-00X-XX	WASHER-PLAIN	Rondelle	2	*	*					41180500
23	5110-092-743-XX	GASKET, MUFFLER	Joint	1	*	*					110092743

FIG. 11 FUEL – TANK/FUEL – VALVE
 Reservoir/Robinet à carburant

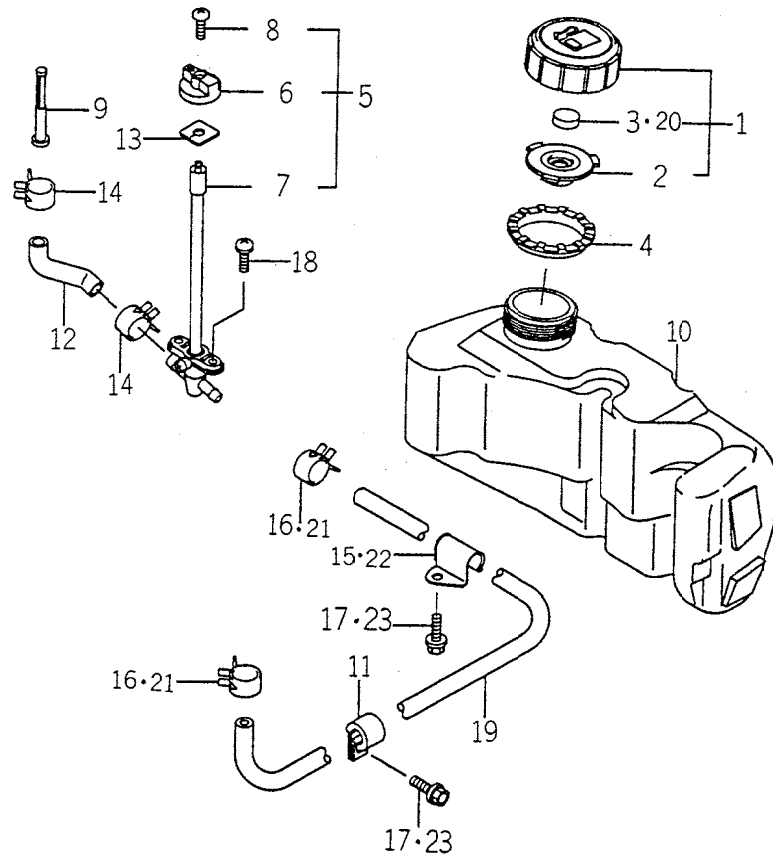

K621-1100

KEY Réf.	PART CODE Pièces No.	DESCRIPTION	Désignation	QTY Quant.	TYPE OF MODEL		Modél	I T C	C O L	G R P	REMARKS Remarques
					FC150V ABC2	FC150V EB02					
1	5510-482-069-XX	CAP-ASSY-TANK	Ens. bouchon	1	*	*					510482069
2	5110-092-831-XX	GASKET	Joint	1	*	*					110092831
3	5491-092-054-XX	ELEMENT BREATHER	Element	1		*					491092054
4	5130-702-077-XX	GUIDE	Guide	1	*	*					130702077
5	5490-192-094-XX	FILTER-FUEL	Robinet	1	*	*					490192094
6	5131-682-303-XX	LEVER	Levier	1	*	*					131682303
7	5161-042-052-XX	FILTER-COMP	Robinet	1	*	*					161042052
8	5920-092-296-XX	SCREW	Vis	1	*	*					920092296
9	5490-192-091-XX	FILTER-FUEL	Robinet	1	*	*					490192091
10	5510-012-214-XX	TANK-COMP-FUEL	Reservoir	1	*	*					510012214
11	5920-372-202-XX	CLAMP	Attache	1	*	*					920372202
12	5920-592-262-XX	TUBE	Tuyau	1	*	*					920592262
13	5920-932-088-XX	SEAL	Joint	1		*					920932088
14	5921-702-009-XX	CLAMP	Attache	2	*	*					921702009
15	5921-702-037-XX	CLAMP	Attache	1		*					921702037
16	5921-702-043-XX	CLAMP	Attache	2		*					921702043
17	5130-B06-12X-XX	BOLT-FLANGED	Vis	2		*					130B0612
18	5233-B05-10X-XX	SCREW-PAN-WP	Vis	2	*	*					233B0510
19	5705-A04-100-0X	TUBE-BRAID	Tuyau	1	*	*					705A041000
20	5182-926-656-00	ELEMENT-BREATHER	Element	1	*	*					318292665600
21	5171-966-812-00	CLAMP	Attache	2	*	*					317196681200
22	5921-702-020-XX	CLAMP	Attache	1	*	*					921702020
23	5130-B06-10X-XX	BOLT-FLANGED	Vis	2	*	*					130B0610

ENGINE

Moteur

FC150V – AB03

FC150V – FB03

FC150V – GB03

FIG. 1 CYLINDER/CRANKCASE
Cylindre/Carter

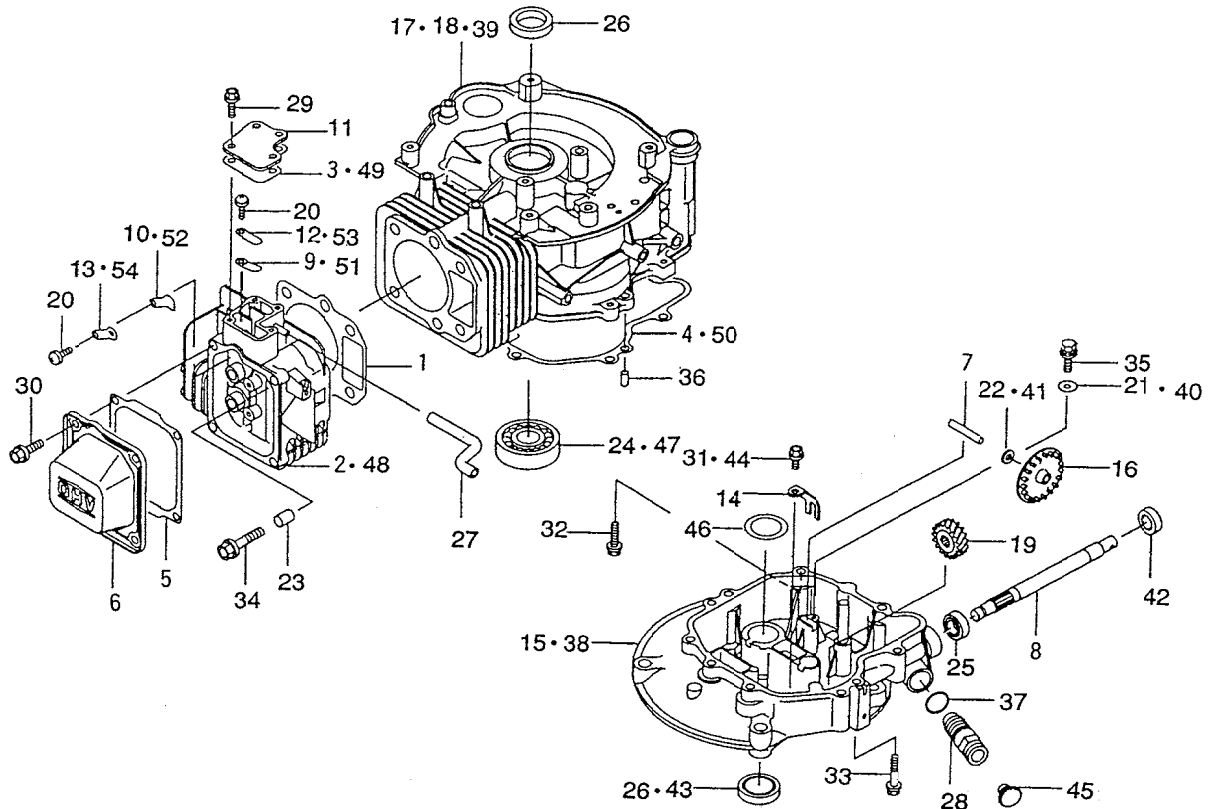

X500-101

KEY Réf.	PART CODE Pièces N°	DESCRIPTION	Désignation	QTY Quant.	TYPE OF MODEL			I T C	C O L	G R P	REMARKS Remarques
					FC150V ABC3	FC150V FB03	Modél FC150V GB03				
1	5110-042-099-XX	GASKET-HEAD	Joint de cylindre	1	*	*	*				110042099
2	5110-086-008-XX	HEAD-COMP-CYLINDER	Culasse	1	*						110086008
3	5110-092-740-XX	GASKET	Joint	1	*	1- -C27854					110092740
4	5110-092-770-XX	GASKET	Joint	1	*	1- -C27854					110092770
5	5110-092-848-XX	GASKET, ROCKER CASE	Joint de boitier	1	*	*	*				110092848
6	5110-222-057-XX	CASE-ROCKER	Boitier	1	*	*	*				110222057
7	5131-072-202-XX	SHAFT	Arbre	1	*	*	*				131072202
8	5131-072-220-XX	SHAFT	Arbre	1	*	*	*				131072220
9	5131-832-258-XX	PLATE	Praque	1	*	1- -F81465					131832258
10	5131-832-259-XX	PLATE	Praque	1	*	1- -F81465					131832259
11	5140-242-180-XX	COVER	Capot	1	*	*	*				140242180
12	5161-262-149-XX	VALVE	Soupape	1	*	1- -F81465					161262149
13	5161-262-150-XX	VALVE	Soupape	1	*	1- -F81465					161262150
14	5210-832-062-XX	ARM	Bras	1	*	*	*				210832062
15	5490-156-055-XX	COVER-CRANKCASE	Carter	1	*						490156055
16	5490-732-055-XX	SLINGER-OIL	Défecteur d'huile	1	*	*	*				490732055
17	5491-202-247-XX	CRANKCASE-COMP	Carter	1	*	*	*				491202247
18	5491-202-185-XX	CRANKCASE-COMP	Carter	1	*						491202185
19	5590-562-790-XX	GEAR-HELICAL	Pignon	1	*	*	*				590562790
20	5920-092-166-XX	SCREW, 5x8	Vis	2	*	*	*				920092166
21	5145-V17-281-AX	WASHER	Rondelle	1	*						3145V17281A
22	5920-222-131-XX	WASHER	Rondelle	1	*						920222131
23	5920-431-264-XX	PIN	Axe	2	*	*	*				920431264
24	5920-452-155-XX	BEARING-BALL	Roulement à billes	1	*						920452155
25	5117-604-241-00	SEAL-OIL	Joint SPI	1	*						311760424100

FIG. 1 CYLINDER/CRANKCASE
Cylindre/Carter

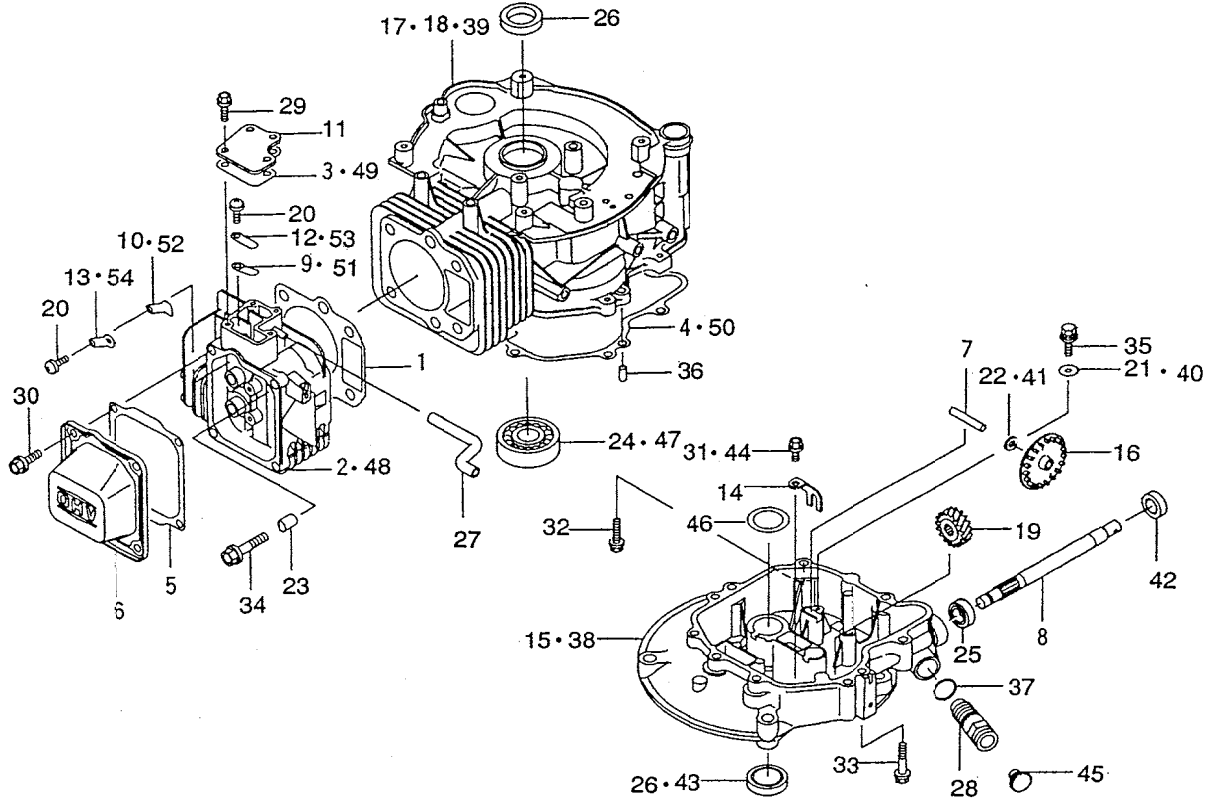

K500-101

KEY Réf.	PART CODE Pièces No.	DESCRIPTION	Désignation	QTY Quant.	TYPE OF MODEL			I T C	C O L	G R P	REMARKS Remarques
					FC150V AB03	FC150V FB03	Modél FC150V GB03				
26	5158-C14-231-AX	SEAL-OIL	Joint SPI	2	*						3158014231A
27	5920-592-256-XX	TUBE	Tuyau	1	*	*	*				920592256
28	5920-662-180-XX	PLUG	Bouchon	1	*	*	*				920662180
29	5130-B05-10X-XX	BOLT-FLANGED	Vis	4	*	*	*				130B0510
30	5130-B06-12X-XX	BOLT-FLANGED	Vis	4	*	*	*				130B0612
31	5130-B06-14X-XX	BOLT-FLANGED	Vis	1	*						130B0614
32	5130-G06-25X-XX	BOLT-FLANGED	Vis	5	*	*	*				130G0625
33	5130-G06-45X-XX	BOLT-FLANGED	Vis	2	*	*	*				130G0645
34	5130-G08-45X-XX	BOLT-FLANGED	Vis	4	*	*	*				130G0845
35	5187-B05-10X-XX	BOLT-UPSET-WSP	Vis	1	*	*	*				187B0510
36	5551-A06-12X-XX	PIN-DOWEL	Pion	2	*	*	*				551A0612
37	5670-D20-15X-XX	O RING	Joint torique	1	*	*	*				670D2015
38	5490-156-088-XX	COVER-CRANKCASE	Carter	1		*	*				490156088
39	5491-202-225-XX	CRANKCASE-COMP	Carter	1		*					491202225
40	5922-002-033-XX	WASHER	Rondelle	1		*	*				922002033
41	5922-002-034-XX	WASHER	Rondelle	1		*	*				922002034
42	5920-492-204-XX	SEAL-OIL	Joint SPI	1		*	*				920492204
43	5920-492-208-XX	SEAL-OIL	Joint SPI	2		*	*				920492208
44	5130-B06-12X-XX	BOLT-FLANGED	Vis	5		*	*				130B0612
45	5920-662-193-XX	PLUG	Bouchon	1		*	*				920662193
46	5922-002-026-XX	WASHER25X42X1	Rondelle	1		*	*				922002026
47	5601-B62-05X-XX	BEARING-BALL	Roulement à billes	1		*	*				601B6205
48	5110-086-023-XX	HEAD-COMP-CYLINDER	Culasse	1		*	*				110086023
49	5110-602-007-XX	GASKET	Joint	1		C27855-	C27855-				110602007
50	5110-602-011-XX	GASKET	Joint	1		C27855-	C27855-				110602011

FIG. 2 PISTON/CRANKSHAFT
Piston/vilebrequin

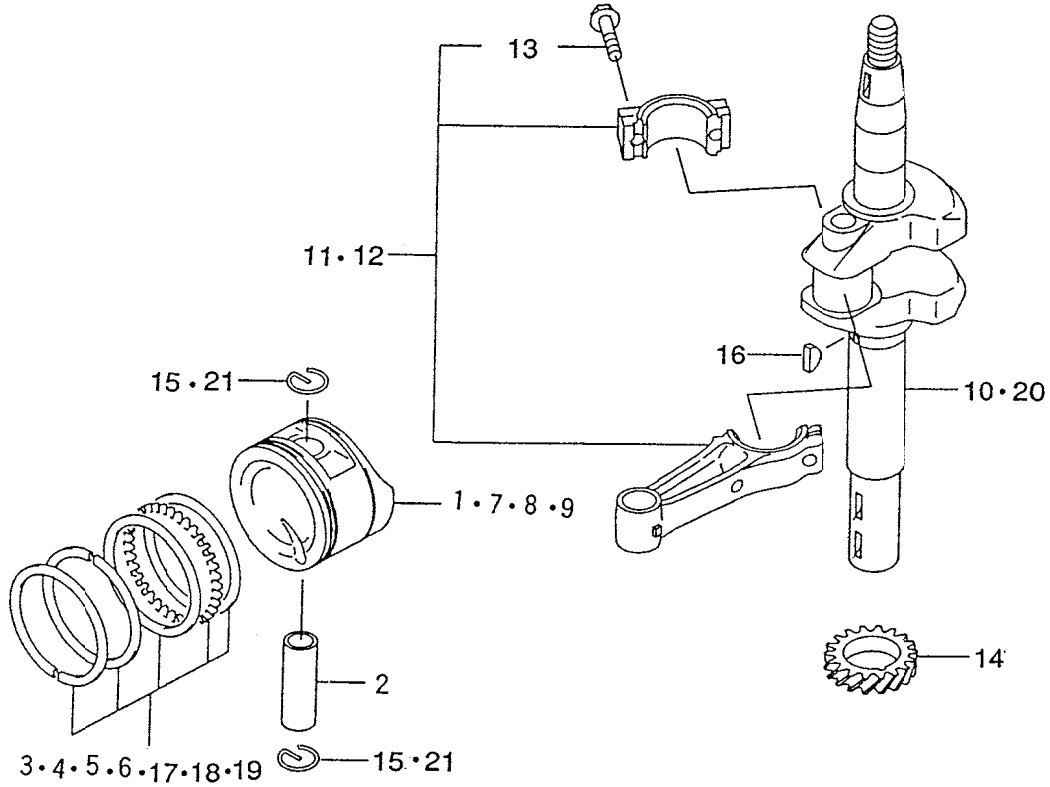

X600-101

KEY Réf.	PART CODE Pièces No.	DESCRIPTION	Désignation	QTY Quant.	TYPE OF MODEL			I T C	C O L	G R P	REMARKS Remarques
					FC150V AB03	FC150V FB03	Modél FC150V GB03				
1	5130-012-109-XX	PISTON-ENGINE	Piston	1	*	*	*				130012109
2	5130-022-074-XX	PIN-PISTON	Axe de piston	1	*	*	*				130022074
3	5130-086-017-XX	RING-SET-PISTON	Jeu de segments	1	*	1- -D58946	1- -D58946				130086017
4	5130-246-002-XX	RING-SET-PISTON 0.75	Jeu de segments	1	T						130246002
5	5130-256-003-XX	RING-SET-PISTON 0.25	Jeu de segments	1	T						130256003
6	5130-256-004-XX	RING-SET-PISTON 0.50	Jeu de segments	1	T						130256004
7	5130-272-058-XX	PISTON-ENGINE 0.75	Piston	1	T						130272058
8	5130-292-094-XX	PISTON-ENGINE L, 0.25	Piston	1	T	T	T				130292094
9	5130-292-095-XX	PISTON-ENGINE L, 0.50	Piston	1	T	T	T				130292095
10	5130-372-359-XX	CRANKSHAFT	Vilebrequin	1	*						130372359
11	5132-516-025-XX	ROD-ASSY-CONNECTING	Bielle	1	*	*	*				132516025
12	5132-516-027-XX	ROD-ASSY U/S=0.50	Bielle	1	T	T	T				132516027
13	5921-502-122-XX	BOLT, CONNECTING ROD	Vis	2	*	*	*				921502122
14	5590-562-726-XX	GEAR-HELICAL	Pignon	1	*	*	*				590562726
15	5315-501-312-2A	RING-SNAP	Circlips	2	*						3155013122A
16	5920-382-093-XX	KEY	Clavette	1	*	*	*				920382093
17	5130-086-030-XX	RING-SET-PISTON	Jeu de segments	1		D58947-	D58947-				130086030
18	5130-256-013-XX	RING-SET-PISTON 0.25	Jeu de segments	1		T	T				130256013
19	5130-256-014-XX	RING-SET-PISTON 0.50	Jeu de segments	1		T	T				130256014
20	5130-372-453-XX	CRANKSHAFT	Vilebrequin	1		*	*				130372453
21	5920-332-161-XX	RING-SNAP	Circlips	2		*	*				920332161

FIG. 3 VALVE/CRANKSHAFT
Soupape/Arbre à cames

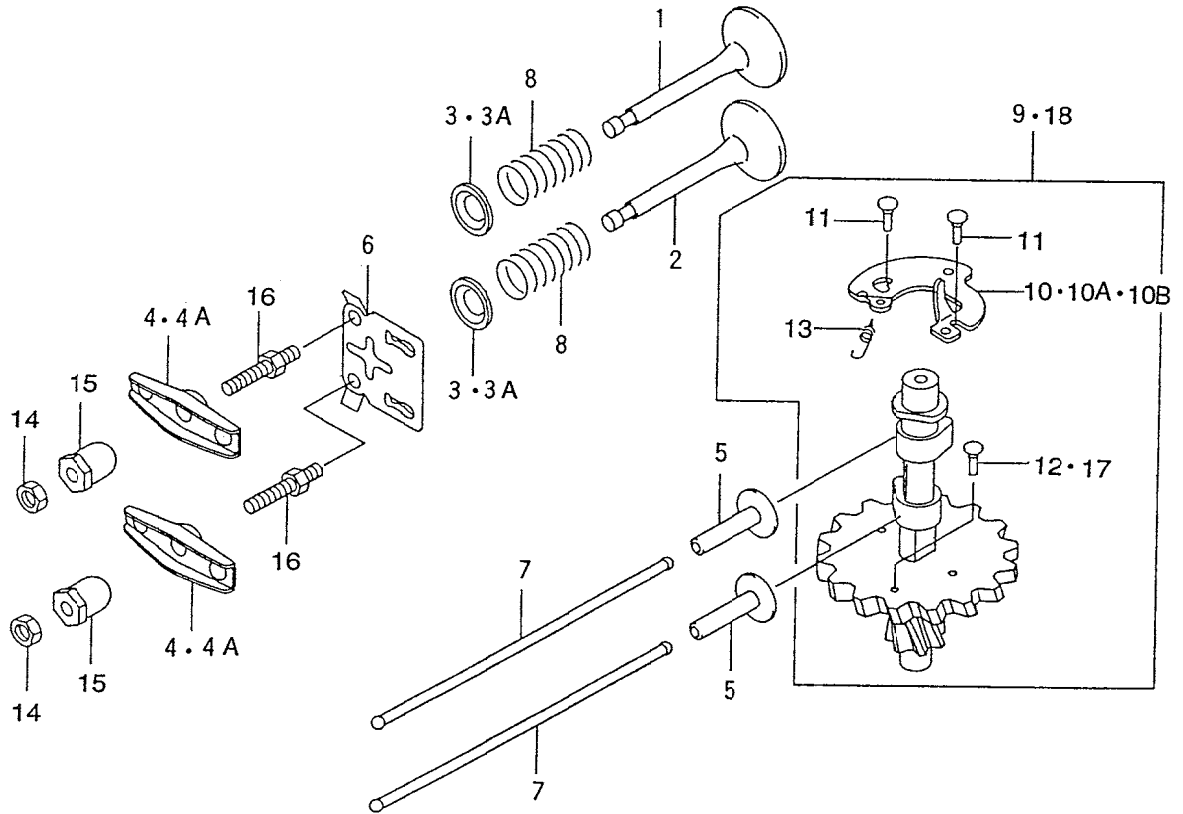

K500-101

KEY Réf.	PART CODE Pièces No.	DESCRIPTION	Désignation	QTY Quant.	TYPE OF MODEL			I T C	C O L	G R P	REMARKS Remarques
					FC150V ABC3	FC150V FB03	Modél FC150V GB03				
1	5120-042-090-XX	VALVE-INTAKE	Soupape d'admission	1	*	*	*				120042090
2	5120-052-074-XX	VALVE-EXHAUST	Soupape d'échappement	1	*	*	*				120052074
3	5120-092-062-XX	RETAINER-VALVE SPRIN	Coupelle	2	*	1- -F8:465					120092062
3A	5120-092-068-XX	RETAINER-VALVE SP	Coupelle	2			F81466-				120092068
4	5120-162-057-XX	ARM-ROCKER	Culbuteur	2	*	1- -G27059	1- -G27059				120162057
4A	5120-162-062-XX	ARM-ROCKER	Culbuteur				G27060-				2120162062
5	5120-322-065-XX	TAPPET	Poussoir	2	*	*	*				120322065
6	5130-702-072-XX	GUIDE	Guide	1	*	*	*				130702072
7	5131-162-065-XX	ROD-PUSH	Pige-poussoir	2	*	*	*				131162065
8	5490-782-064-XX	SPRING-ENGINE VALVE	Ressort	2	*	*	*				490782064
9	5491-182-068-XX	CAMSHAFT-COMP	Arbre a cames	1	*						491182068
10	5211-182-069-XX	DECOMPRESSOER	Décompresseur	1	*	1- -B74379					211182069
10A	5211-182-082-XX	DECOMPRESSOR	Décompresseur	1		B74380- -F81465	B74380- -F81465				211182082
103	5211-182-090-XX	DECOMPRESSOR	Décompresseur	1			F81466-				211182090
11	5920-432-168-XX	PIN	Axe	2	*	*	*				920432168
12	5920-432-169-XX	PIN	Axe	1	*						920432169
13	5920-812-342-XX	SPRING	Ressort	1	*	*	*				920812342
14	5920-152-240-XX	NUT, 6MM	Ecrou	2	*	*	*				920152240
15	5920-152-253-XX	NUT	Ecrou	2	*	*	*				920152253
16	5921-502-102-XX	BOLT	Vis	2	*	*	*				921502102
17	5920-432-168-XX	PIN	Axe	1		*	*				920432168
18	5491-182-119-XX	CAMSHAFT-COMP	Arbre a cames	1		*	*				491182119

FIG. 6 ELECTRIC — EQUIPMENT
Électricité

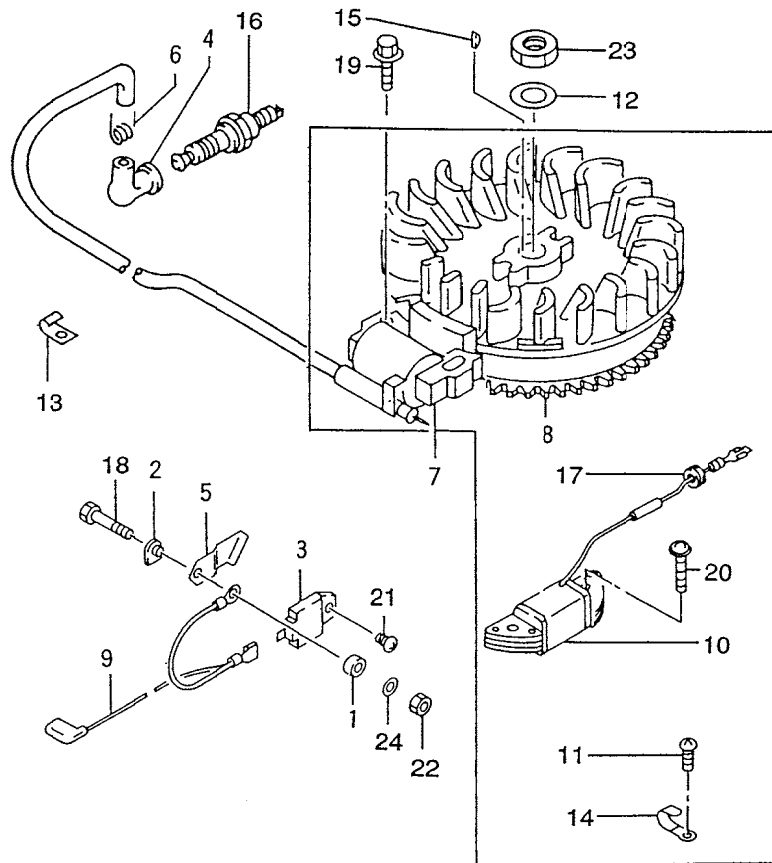

X500-101

KEY Ref.	PART CODE Pieces No.	DESCRIPTION	Designation	QTY Quant.	TYPE OF MODEL			I T C	C O L	G R P	REMARKS Remarques
					FC150V AB03	FC150V FB03	FC150V GB03				
1	5140-242-183-XX	COVER	Capot	1	*						140242183
2	5160-732-124-XX	INSULATOR	Ecran thermique	1	*						160732124
3	5211-192-119-XX	IGNITER	Bougie d'allumage	1	*						211192119
4	5172-708-418-BX	CAP-SPARK PLUG	Capuchon	1	*						3172708418B
5	5211-692-066-XX	TERMINAL	Borne	1	*						211692066
6	5172-708-419-AX	TERMINAL	Borne	1	*						3172708419A
7	5211-712-153-XX	COIL-ASSY-IGNITION	Ens. bobine d'allumage	1	*						211712153
8	5211-932-086-XX	FLYWHEEL-COMP	Ens. volant	1	*						211932086
9	5260-112-224-XX	WIRE-LEAD	Fil	1	*						260112224
10	5590-312-076-XX	COIL CHARGING	Bobine de charge	1	*						590312076
11	5144-053-092-AX	SCREW	Vis	1	*						3144053092A
12	5144-013-482-AX	WASHER	Rondelle	1	*						3144013482A
13	5105-018-162-AX	CLAMP	Attache	1	*						3105018162A
14	5920-372-104-XX	CLAMP	Attache	1	*						920372104
15	5920-382-077-XX	KEY	Clavette	1	*						920382077
16	5920-702-081-XX	PLUG-SPARK, BP5ES (NGK)	Bougie	1	*						920702081
17	5920-712-122-XX	GROMMET	Passe-fil	1	*						920712122
18	5110-B05-22X-XX	BOLT-FLANGED	Vis	1	*						110B0522
19	5130-606-25X-XX	BOLT-FLANGED	Vis	2	*						130G0625
20	5224-B06-25X-XX	SCREW-PAN-WP	Vis	2	*						224B0625
21	5241-B04-12X-XX	SCREW-PAN-WP+-	Vis	1	*						241B0412
22	5311-B05-00X-XX	NUT-HEX	Ecrou	1	*						311B0500
23	5314-G14-00X-XX	NUT-HEX-FINE	Ecrou	1	*						314G1400
24	5410-B05-00X-XX	W-PLAIN-S	Rondelle	1	*						410B0500

FIG. 7 CONTROL – EQUIPMENT
Commandes

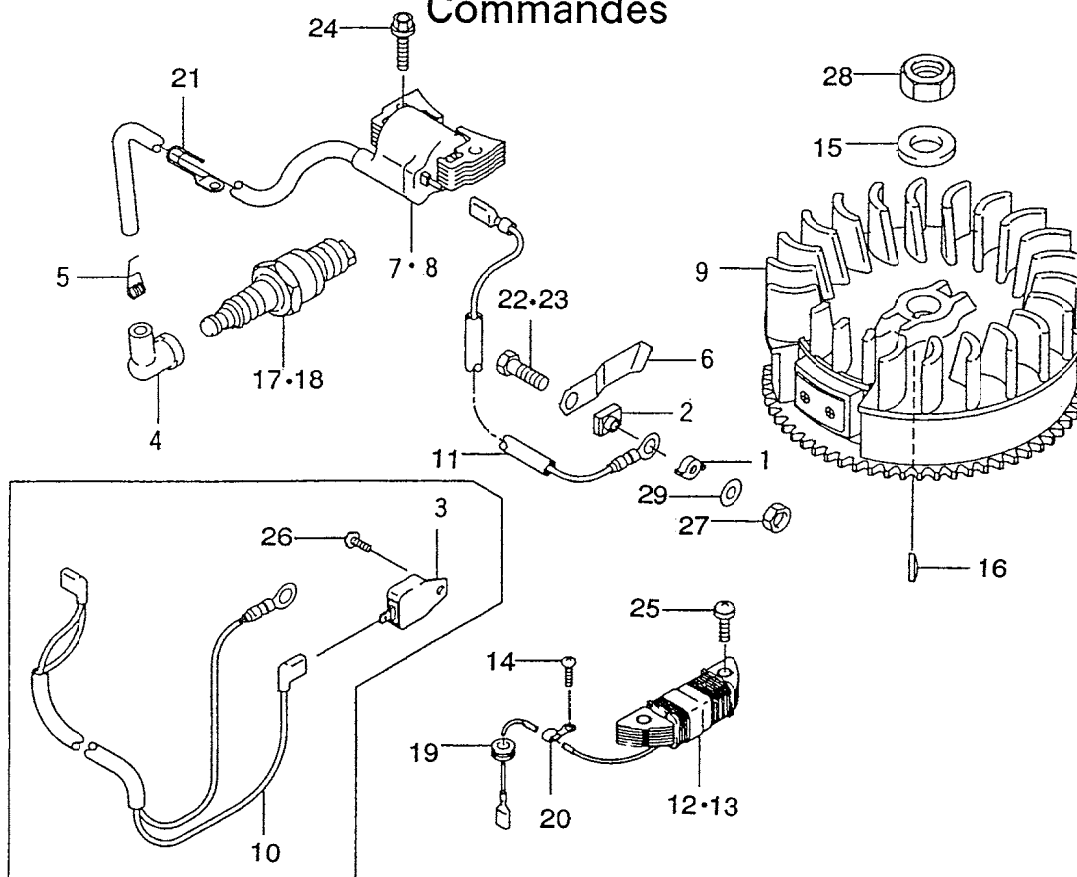

K500-101

KEY Réf.	PART CODE Pièces No.	DESCRIPTION	Désignation	QTY Quant.	TYPE OF MODEL			I T C	C O L	G R P	REMARKS Remarques
					FC150V AB03	FC150V FB03	Modél FC150V GB03				
1	5140-242-183-XX	COVER	Capot	1		*	*				140242183
2	5160-732-124-XX	INSULATOR	Ecran thermique	1		*	*				160732124
3	5211-192-139-XX	IGNITER	Bougie d'allumage	1		*	*				211192139
4	5211-302-066-XX	CAP-SPARK PLUG	Capuchon	1		*	*				211302066
5	5211-692-004-XX	TERMINAL	Borne	1		*	*				211692004
6	5211-692-066-AX	TERMINAL	Borne	1		*	*				211692066
7	5211-712-176-XX	COIL-ASSY-IGNITION	Ens. bobine d'allumage	1		*					211712176
8	5211-712-200-XX	COIL-ASSY-IGNITION	Ens. bobine d'allumage	1			*				211712200
9	5211-932-151-XX	FLYWHEEL-ASSY	Ens. volant	1		*	*				211932151
10	5260-112-279-XX	WIRE-LEAD	Fil	1		*					260112279
11	5260-112-306-XX	WIRE-LEAD	Fil	1			*				260112306
12	5590-312-076-XX	COIL-CHARGING	Bobine de charge	1		*	*				590312076
13	5590-312-110-XX	COIL-CHARGING	Bobine de charge	1		*	*				590312110
14	5920-092-307-XX	SCREW	Vis	1		*	*				920092307
15	5920-222-102-XX	WASHER	Rondelle	1		*	*				920222102
16	5920-382-077-XX	KEY	Clavette	1		*	*				920382077
17	5920-702-084-XX	PLUG-SPARK, BP6ES (NGK)	Bougie	1		*					920702084
18	5920-702-087-XX	PLUG-SPARK, BP6ES (NGK)	Bougie	1			*				920702087
19	5920-712-122-XX	GROMMET	Passe-fil	1		*	*				920712122
20	5921-702-029-XX	CLAMP	Attache	2		*	*				921702029
21	5921-702-064-XX	CLAMP	Attache	2		*	*				921702064
22	5110-B05-22X-XX	BOLT	Vis	1		*	*				110B0522
23	5112-B05-22X-XX	BOLT	Vis	1		*	*				112B0522
24	5130-G06-25X-XX	BOLT	Vis	2		*	*				130G0625
25	5224-B06-25X-XX	SCREW	Vis	2		*	*				224B0625

FIG. 8 CARBURETOR
Carburateur

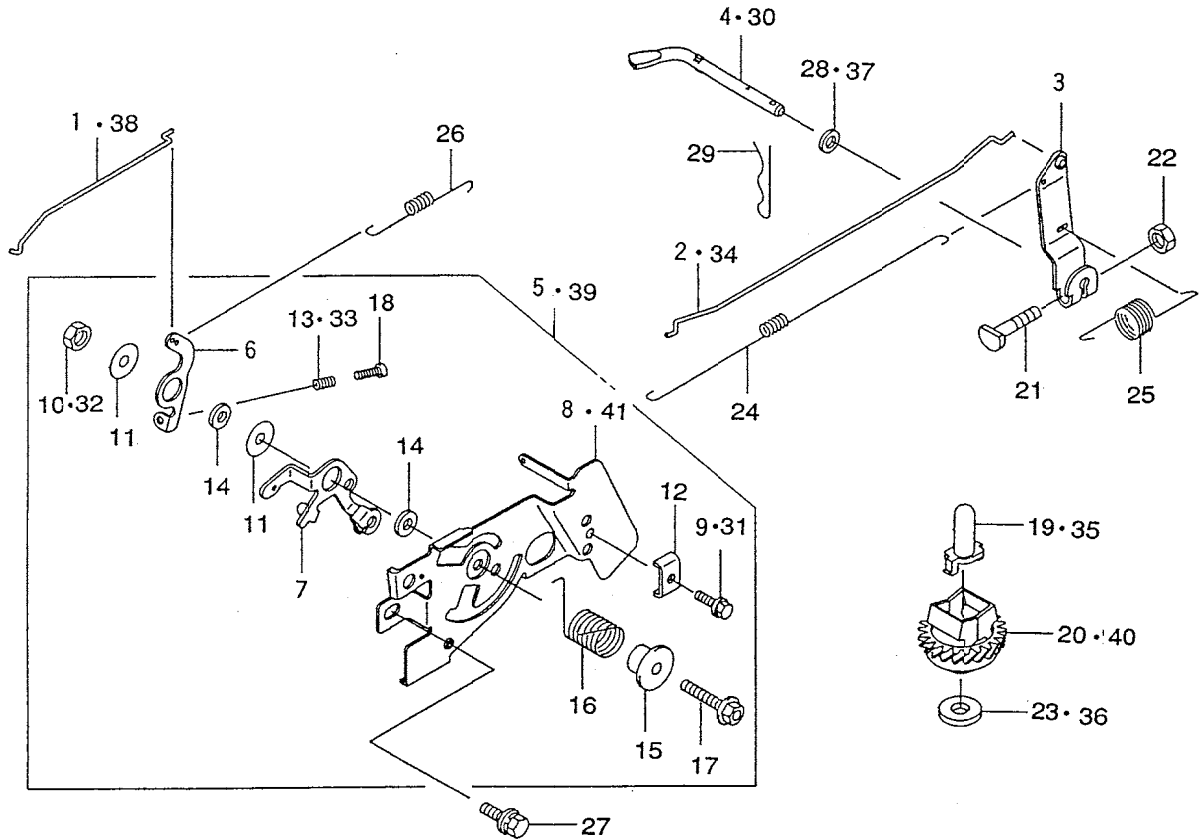

K500-01

KEY Réf.	PART CODE Pièces No.	DESCRIPTION	Désignation	QTY Quant.	TYPE OF MODEL			I T C	C O L	G R P	REMARKS Remarques
					FC150V AB03	FC150V FB03	Modél FC150V GB03				
1	5161-692-104-XX	LINK-CHOKE	Tige	1	*						161692104
2	5161-712-060-XX	LINK	Tige	1	*						161712060
3	5211-872-060-XX	ARM-ASSY	Ens. bras	1	*	*	*				211872060
4	5390-032-066-XX	ARM-PIVOT	Bras	1	*						390032066
5	5391-802-549-XX	PANEL-ASSY-CONTROL	Ens. panneau de commande	1	1- -F06974						391802549
6	5131-682-288-XX	LEVER	Levier	1	*	*	*				131682288
7	5131-682-298-XX	LEVER	Levier	1	*	*	*				131682298
8	5592-262-201-XX	PANEL-CONTROL	Panneau de commande	1	1- -F06974						592262201
9	5107-011-225-AX	BOLT	Vis	1	*						3107011225A
10	5144-015-385-AX	NUT	Ecrou	1	*						3144015385A
11	5920-222-372-XX	WASHER, 6x19x1.2	Rondelle	2	*	*	*				920222372
12	5920-372-209-XX	CLAMP	Attache	1	*	*	*				920372209
13	5144-015-321-BX	SPRING	Ressort	1	*						3144015321B
14	5921-432-135-XX	COLLAR, 6x13x2.3	Entretoise	2	*	*	*				921432135
15	5921-432-148-XX	COLLAR	Entretoise	1	*	*	*				921432148
16	5921-442-211-XX	SPRING	Ressort	1	*	*	*				921442211
17	5130-B06-30X-XX	BOLT-FLANGED	Vis	1	*	*	*				130B0630
18	5214-B04-20X-XX	SCREW-PAN+-	Vis	1	*	*	*				214B0420
19	5144-015-121-BX	SLEEVE	Bague	1	*						3144015121B
20	5491-102-076-XX	GOVERNOR-ASSY	Ens. regulateur	1	1- -G27059	1- -G27059					491102076
21	5920-022-269-XX	BOLT	Vis	1	*	*	*				920022269
22	5920-151-193-XX	NUT	Ecrou	1	*	*	*				920151193
23	5144-015-135-AX	WASHER	Rondelle	1	*						3144015135A
24	5920-812-299-XX	SPRING, LINK	Ressort	1	*	*	*				920812299
25	5921-442-213-XX	SPRING	Ressort	1	*	*	*				921442213

FIG. 9 CARBURETOR (AB03)
Carburateur

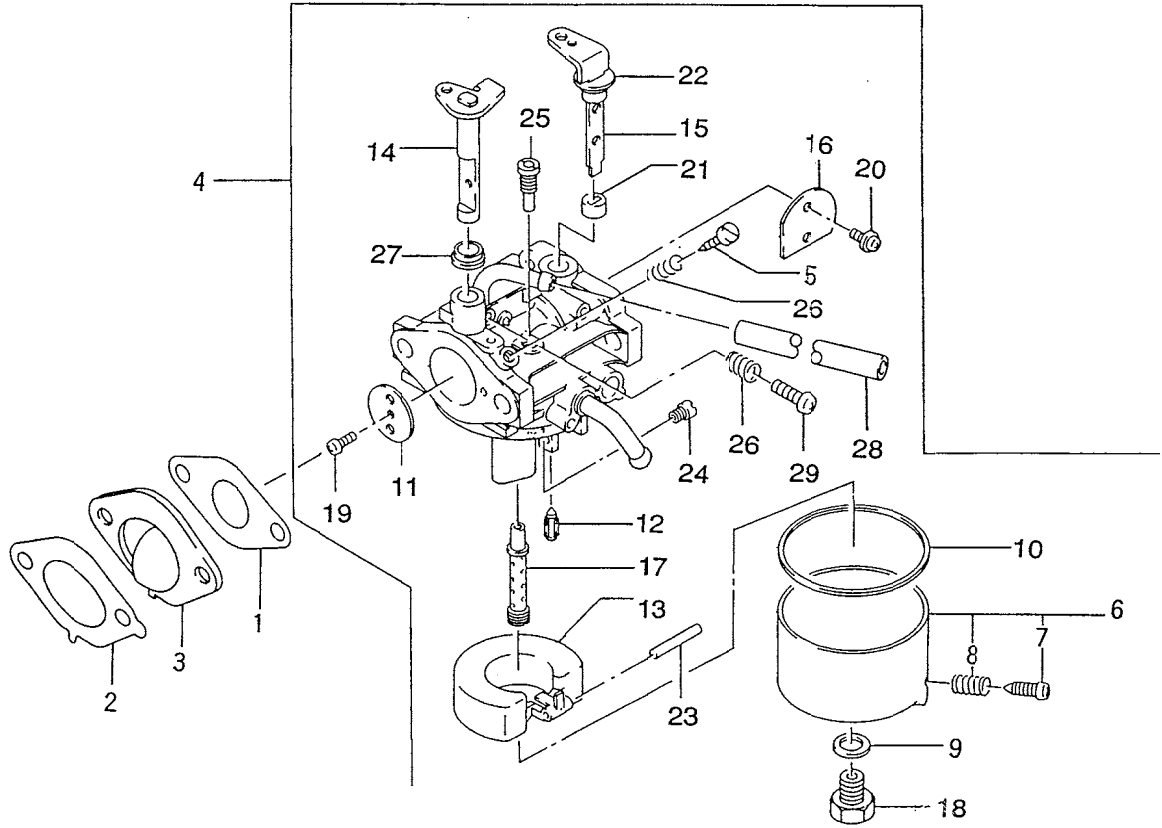

K500-101

KEY Réf.	PART CODE Pièces No.	DESCRIPTION	Désignation	QTY Quant.	TYPE OF MODEL			I T C	C O L	G R P	REMARKS Remarques
					FC150V AB03	FC150V FB03	FC150V GB03				
1	5110-092-746-XX	GASKET, CARBURETOR	Joint	1	*						110092746
2	5110-092-833-XX	GASKET, INSULATOR	Joint	1	*						110092833
3	5160-732-136-XX	INSULATOR	Ecran thermique	1	*						160732136
4	5150-032-006-XX	CARBURETOR-ASSY.	Ens. carburateur	1	*						150032006
5	5164-706-114-00	SCREW-PILOT AIR	Vis	1	*						316470611400
6	5145-766-130-AX	CHAMBER-FLOAT	Chambre du flotteur	1	*						3145766130A
7	5154-706-133-AX	SCREW	Vis	1	*						3154706133A
8	5131-226-116-00	SPRING	Ressort	1	*						313122611600
9	5144-996-159-AX	GASKET	Joint	1	*						3144996159A
10	5145-986-128-AX	GASKET	Joint	1	*						3145986128A
11	5136-506-101-00	VALVE-THROTTLE, #110	Boisseau	1	*						313650610100
12	5144-996-122-AX	VALVE-FLOAT	Soupape	1	*						3144996122A
13	5160-312-058-XX	FLOAT	Flotteur	1	*						160312058
14	5160-412-178-XX	SHAFT-CARBURETOR, TH	Axe papillon	1	*						160412178
15	5160-412-197-XX	SHAFT-CARBURETOR, CH	Axe papillon	1	*						160412197
16	5161-262-173-XX	VALVE, CHOKE	Volet d'air	1	*						161262173
17	5491-212-113-XX	NOZZLE-MAIN, #2A	Gicleur principal	1	*						491212113
18	5144-996-143-AX	BOLT	Vis	1	*						3144996143A
19	5165-506-137-AX	SCREW	Vis	1	*						3165506137A
20	5920-092-149-XX	SCREW	Vis	2	*						920092149
21	5145-986-138-AX	COLLAR	Entretoise	1	*						3145986138A
22	5145-986-157-AX	COLLAR	Entretoise	1	*						3145986157A
23	5144-996-127-AX	PIN	Axe	1	*						3144996127A
24	5920-632-096-XX	JET-MAIN, #68.8	Gicleur principal	1	*						920632096
25	5920-642-065-XX	JET-PILOT, #38.8	Vis de mélange	1	*						920642065

FIG. 10 AIR - FILTER/MUFFLER
 Filtre à air/Echappement

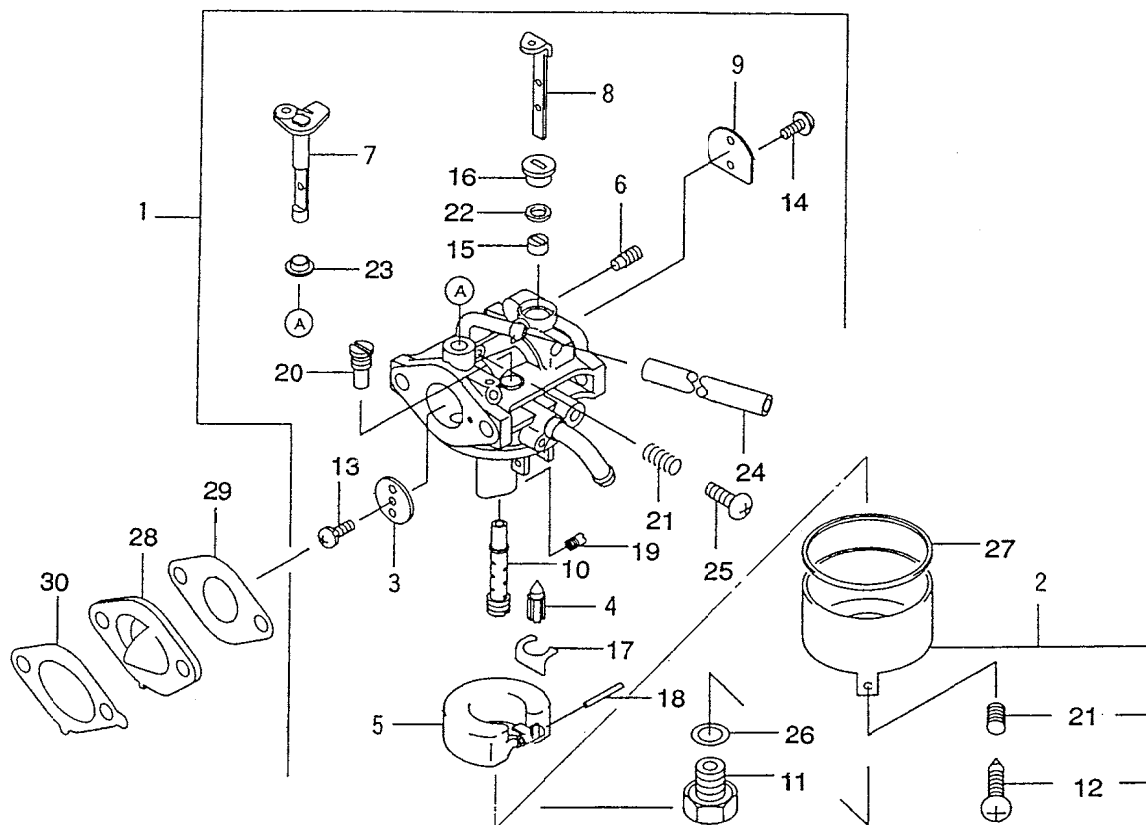

X500-101

KEY Réf.	PART CODE Pièces No.	DESCRIPTION	Désignation	QTY Quant.	TYPE OF MODEL			I T C	C O L	G R P	REMARKS Remarques
					FC150V AB03	FC150V FB03	FC150V GB03				
1	5150-032-364-XX	CARBURETOR-ASSY.	Ens. carburateur	1		*	*				150032364
2	5160-202-052-XX	CHAMBER-FLOAT	Chambre du flotteur	1		*	*				160202052
3	5160-252-001-XX	VALVE-THROTTLE, #110	Boisseau	1		*	*				160252001
4	5160-302-083-XX	VALVE-FLOAT	Soupape	1		*	*				160302083
5	5160-312-058-XX	FLOAT	Flotteur	1		*	*				160312058
6	5160-352-063-XX	JET-AIR, #0.9	Vis de richesse	1		*	*				160352063
7	5160-412-178-XX	SHAFT-CARBURETOR, TH	Axe volet d'air	1		*	*				160412178
8	5160-412-197-XX	SHAFT-CARBURETOR, CH	Axe volet d'air	1		*	*				160412197
9	5161-262-199-XX	VALVE, CHOKE	Volet d'air	1		*	*				161262199
10	5491-212-189-XX	NOZZLE-MAIN, #2A	Gicleur principal	1		*	*				491212189
11	5920-022-011-XX	BOLT	Vis	1		*	*				920022011
12	5920-092-015-XX	SCREW	Vis	1		*	*				920092015
13	5920-092-024-XX	SCREW	Vis	1		*	*				920092024
14	5920-092-149-XX	SCREW	Vis	2		*	*				920092149
15	5920-272-003-XX	COLLAR	Entretoise	1		*	*				920272003
16	5920-272-004-XX	COLLAR	Entretoise	1		*	*				920272004
17	5920-332-067-XX	RING-SNAP	Goupille à ressort	1		*	*				920332067
18	5920-432-006-XX	PIN	Axe	1		*	*				920432006
19	5920-632-096-XX	JET-MAIN, #68.8	Gicleur principal	1		*	*				920632096
20	5920-642-002-XX	JET-PILOT, #45	Vis de melange	1		*	*				920642002
21	5920-812-009-XX	SPRING	Ressort	2		*	*				920812009
22	5920-932-101-XX	SEAL	Joint	1		*	*				920932101
23	5921-432-143-XX	COLLAR	Entretoise	1		*	*				921432143
24	5921-902-163-XX	TUBE, 4x7x125	Tuyau	1		*	*				921902163
25	5214-804-12X-XX	SCREW-PAN+-	Vis	1		*	*				21480412

FIG. 11 FUEL – TANK/FUEL – VALVE
Reservoir/Robinet à carburant

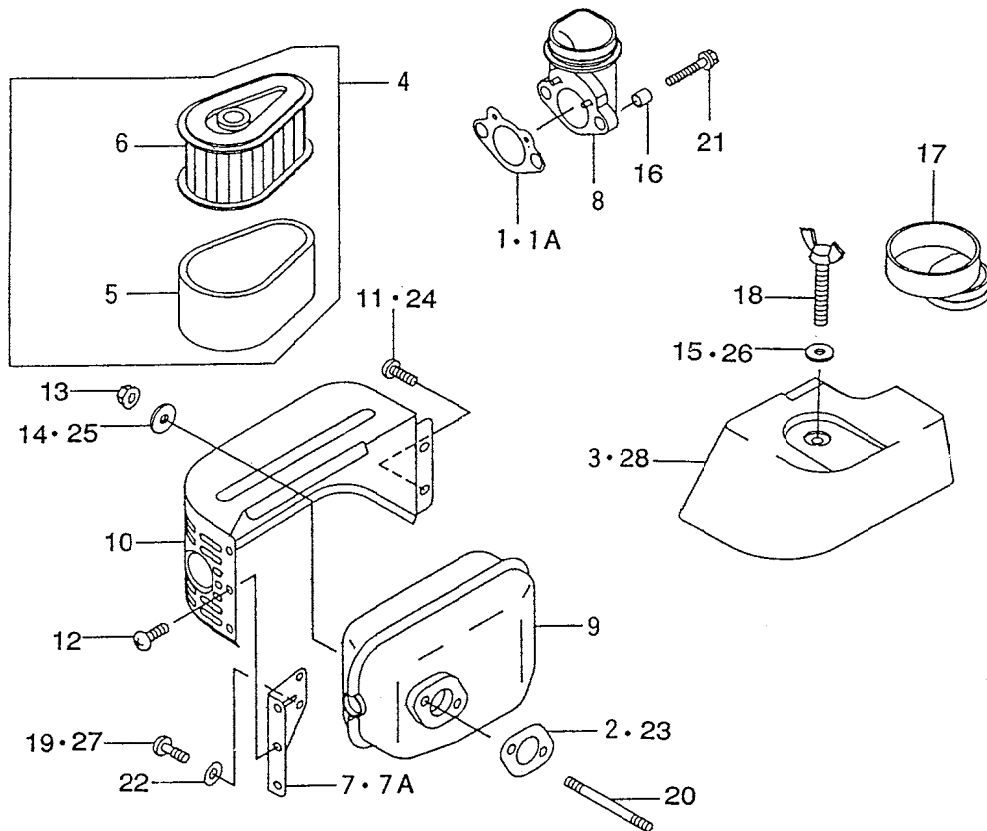

K500-101

KEY Réf.	PART CODE Pièces No.	DESCRIPTION	Désignation	QTY Quant.	TYPE OF MODEL			I T C	C O L	G R P	REMARKS Remarques
					FC150V AB03	FC150V FB03	Modél FC150V GB03				
1	5110-092-742-XX	GASKET, INTAKE PIPE	Joint	1	*		1- -C27854				110092742
1A	5110-602-067-XX	GASKET, INTAKE PIPE	Joint	1			C27855-				110602067
2	5110-092-743-XX	GASKET, MUFFLER	Joint	1	*						110092743
3	5110-122-272-XX	CAP, AIR FILTER	Capuchon	1	*	*					110122272
4	5110-292-010X-X	ELEMENT-ASSY-AIR FIL	Ens. element	1	*	*	*				110292002
5	5110-132-119-XX	ELEMENT-AIR FILTER	Element	1	*	*	*				110132119
6	5110-132-120-XX	ELEMENT-AIR FILTER	Element	1	*	*	*				110132120
7	5110-462-053-XX	BRACKET	Support	1	*	*					110462053
7A	5110-492-002-XX	BRACKET	Support	1			*				110492002
8	5160-602-129-XX	PIPE-INTAKE	Tubulure d'admission	1	*	*	*				160602129
9	5490-702-491-XX	MUFFLER-COMP	Echappement	1	*	*	*				490702491
10	5491-062-446-XX	COVER-MUFFLER	Couvercle	1	*	*	*				491062446
11	5920-092-104-XX	SCREW	Vis	2	*						920092104
12	5920-092-166-XX	SCREW, 5x8	Vis	3	*	*	*				920092166
13	5920-151-193-XX	NUT	Ecrou	2	*	*	*				920151193
14	5127-502-883-00	WASHER	Rondelle	2	*						312750288300
15	5920-222-136-XX	WASHER	Rondelle	1	*						920222136
16	5920-262-272-XX	SPACER, 6.2x7.8x8	Pièce d'écartement	2	*	*	*				920262272
17	5920-592-257-XX	TUBE	Tuyau	1	*	*	*				920592257
18	5921-502-101-XX	BOLT	Vis	1	*	*	*				921502101
19	5130-805-10X-XX	SCREW-PAN	Vis	2	*						13080510
20	5172-606-80X-XX	BOLT-STUD	Goujon	2	*	*	*				17260680
21	5186-806-80X-XX	BOLT-UPSET-WP	Vis	2	*	*	*				18680680
22	5411-805-00X-XX	WASHER-PLAIN	Rondelle	2	*	*	*				41180500
23	5110-602-009-XX	GASKET, MUFFLER	Joint	1		*	*				110602009

FIG. 12 RECOIL STARTER
Lanceur

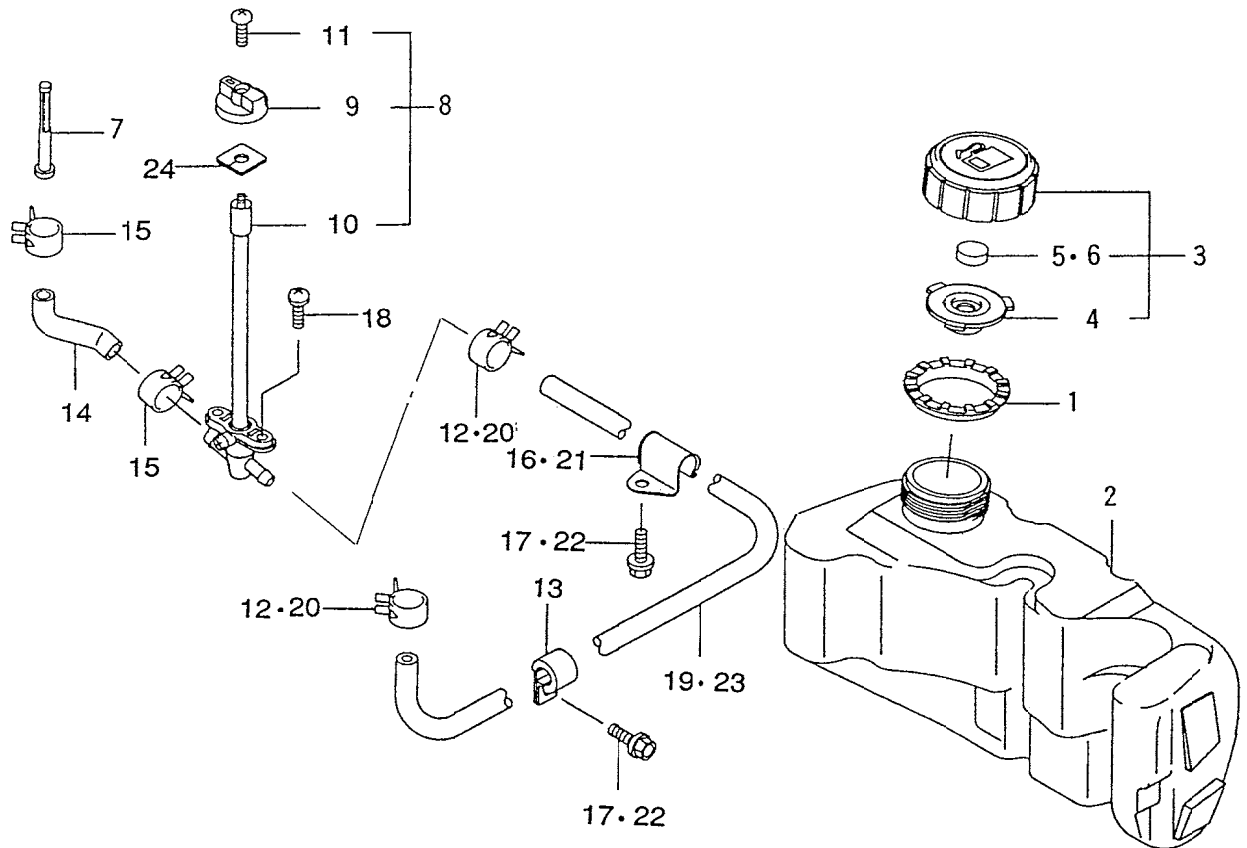

K500-101

KEY Réf.	PART CODE Pièces No.	DESCRIPTION	Désignation	QTY Quant.	TYPE OF MODEL			I T C	C O L	G R P	REMARKS Remarques
					FC150V AB03	FC150V FE03	Modél FC150V GB03				
1	5130-702-077-XX	GUIDE	Guide	1	*	*	*				130702077
2	5510-012-214-XX	TANK-COMP-FUEL	Reservoir	1	*	*	*				510012214
3	5510-482-069-XX	CAP-ASSY-TANK	Ens. bouchon	1	*	*	*				510482069
4	5110-092-831-XX	GASKET	Joint	1	*	*	*				110092831
5	5182-926-656-00	ELEMENT-BREATHER	Element	1	*						318292665600
6	5491-092-054-XX	ELEMENT-BREATHER	Element	1		*	*				491092054
7	5490-192-091-XX	FILTER-FUEL	Robinet	1	*	*	*				490192091
8	5490-192-094-XX	FILTER-FUEL	Robinet	1	*	*	*				490192094
9	5131-682-303-XX	LEVER	Levier	1	*	*	*				131682303
10	5161-042-052-XX	FILTER-COMP	Robinet	1	*	*	*				161042052
11	5920-092-296-XX	SCREW	Vis	1	*	*	*				920092296
12	5171-966-812-00	CLAMP	Attache	2	*						317196681200
13	5920-372-202-XX	CLAMP	Attache	1	*	*	*				920372202
14	5920-592-262-XX	TUBE	Tuyau	1	*	*	*				920592262
15	5921-702-009-XX	CLAMP	Attache	2	*	*	*				921702009
16	5921-702-020-XX	CLAMP	Attache	1	*						921702020
17	5130-B06-10X-XX	BOLT-FLANGED	Vis	2	*						130B0610
18	5233-B05-10X-XX	SCREW-PAN-WP+-	Vis	2	*	*	*				233B0510
19	5705-A04-100-0X	TUBE-BRAID L=405MM	Tuyau	1	*						705A041000
20	5921-702-043-XX	CLAMP	Attache	2		*	*				921702043
21	5921-702-037-XX	CLAMP	Attache	1		*	*				921702037
22	5130-B06-12X-XX	BOLT-FLANGED	Vis	2		*	*				130B0612
23	5921-902-068-XX	TUBE-4. 8X10. 3X415	Tuyau	1		*	*				921902068
24	5920-932-088-XX	SEAL	Joint	1		*	*				920932088

FIG. 13 ELECTRIC STARTER
Démarrreur

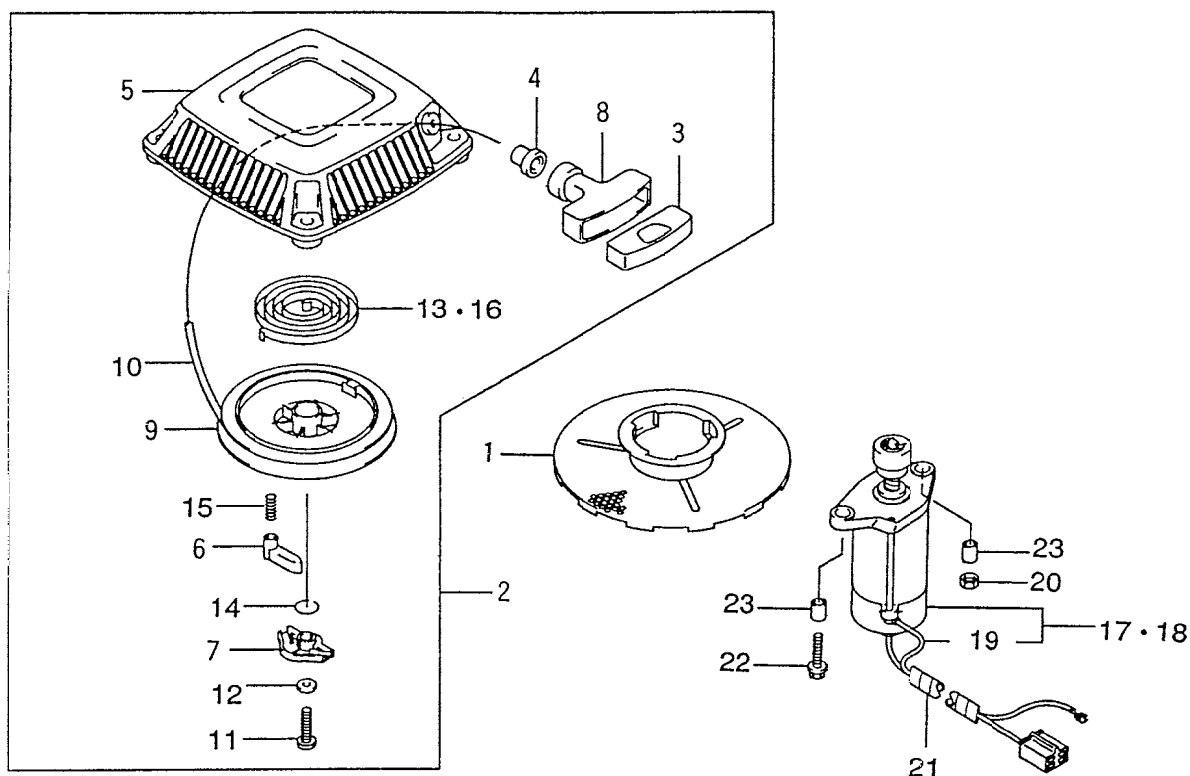

K500-101

KEY Réf.	PART CODE Pièces No.	DESCRIPTION	Désignation	QTY Quant.	TYPE OF MODEL			Mocél FC150V GB03	I T C	C O L	G R P	REMARKS Remarques
					FC150V AB03	FC150V FB03	FC150V GB03					
1	5490-802-143-XX	PULLEY-STARTING	Bol	1	*	*	*					490802143
2	5490-882-379-XX	STARTER-RECOIL	Lanceur	1	*	*	*					490882379
3	5110-122-255-XX	CAP, GRIP	Capuchon	1	*	*	*					110122255
4	5130-702-064-XX	GUIDE, ROPE	Guide	1	*	*	*					130702064
5	5130-912-113-XX	HOLDER, RECOIL	Support	1	*	*	*					130912113
6	5131-652-072-XX	PAWL, RECOIL STARTER	Cliquet	1	*	*	*					131652072
7	5391-082-059-XX	RETAINER-SPRING	Couplie	1	*	*	*					391082059
8	5460-752-082-XX	GRIP, RECOIL STARTER	Poignée	1	*	*	*					460752082
9	5591-012-079-XX	REEL, RECOIL STARTER	Poulie	1	*	*	*					591012079
10	5591-062-115-XX	ROPE, 3. 8x1600	Corde	1	*	*	*					591062115
11	5920-092-280-XX	SCREW, 5x18	Vis	1	*	*	*					920092280
12	5920-222-384-XX	WASHER, 5x12. 8x1.2	Rondelle	1	*	*	*					920222384
13	5156-013-452-AX	SPRING, RECOIL	Ressort spiral	1	*							3156013452A
14	5921-442-176-XX	SPRING	Ressort	1	*	*	*					921442176
15	5921-442-177-XX	SPRING, RETURN	Ressort de rappel	1	*	*	*					921442177
16	5920-812-265-XX	SPRING, RECOIL	Ressort spiral	1		*	*					920812265
17	5211-632-100-XX	STARTER-ELECTRIC	Demarreur	1		*						211632100
18	5211-632-117-XX	STARTER-ELECTRIC	Demarreur	1			*					211632117
19	5260-112-283-XX	WIRE-LEAD	Fil	1		*	*					260112283
20	5920-151-193-XX	NUT	Ecrou	1		*	*					920151193
21	5920-592-261-XX	TUBE	Tuyau	1		*	*					920592261
22	5130-606-30X-XX	BOLT-FLANGED	Vis	1		*	*					13060630
23	5552-B10-12X-XX	PIN-DOWEL	Pion	2		*	*					552B1012

ENGINE
Moteur

FC150V – EB05

FIG. 1 CYLINDER/CRANKCASE
Cylindre/Carter

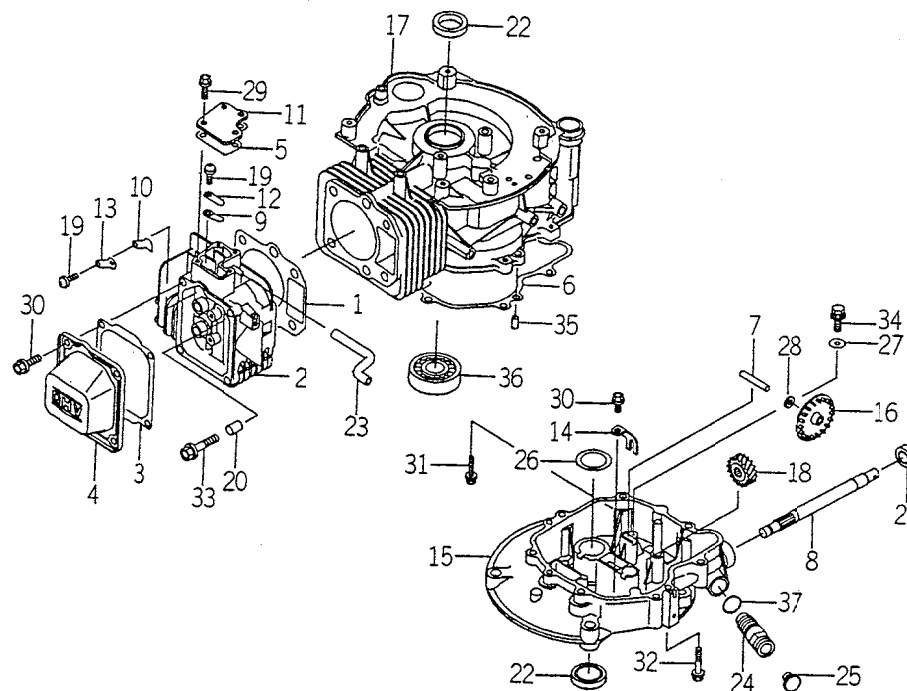

X500-101

KEY Réf.	PART CODE Pièces No.	DESCRIPTION	Désignation	QTY Quant.	TYPE OF MODEL			I T C	C O L	G R P	REMARKS Remarques
					FC150V EB05	Modél					
1	5110-042-099-XX	GASKET-HEAD	Joint de cylindre	1	*						110042099
2	5110-086-023-XX	HEAD-COMP-CYLINDER	Culasse	1	*						110086023
3	5110-092-848-XX	GASKET, ROCKER CASE	Joint de boitier	1	*						110092848
4	5110-222-057-XX	CASE-ROCKER	Boitier	1	*						110222057
5	5110-602-007-XX	GASKET, COVER	Joint	1	*						110602007
6	5110-602-011-XX	GASKET, CRANKCASE COV	Joint de carter	1	*						110602011
7	5131-072-202-XX	SHAFT	Arbre	1	*						131072202
8	5131-072-220-XX	SHAFT	Arbre	1	*						131072220
9	5132-702-049-XX	PLATE	Praque	1	*						1132702049
10	5132-702-050-XX	PLATE	Praque	1	*						1132702050
11	5140-242-180-XX	COVER	Capot	1	*						140242180
12	5161-262-201-XX	VALVE	Soupape	1	*						161262201
13	5161-262-202-XX	VALVE	Soupape	1	*						161262202
14	5210-832-062-XX	ARM	Bras	1	*						210832062
15	5490-156-088-XX	COVER-CRANKCASE	Carter	1	*						490156088
16	5490-732-055-XX	SLINGER-OIL	Défecteur d'huile	1	*						490732055
17	5491-202-240-XX	CRANKCASE-COMP	Carter	1	*						491202240
18	5590-562-790-XX	GEARHELICAL	Pignon	1	*						590562790
19	5920-092-166-XX	SCREW, 5x8	Vis	2	*						920092166
20	5920-431-264-XX	PIN	Axe	2	*						920431264
21	5920-452-204-XX	SEAL-OIL	Joint SPI	1	*						920452204
22	5920-492-208-XX	SEAL-OIL	Joint SPI	2	*						920492208
23	5920-592-256-XX	TUBE	Tuyau	1	*						920592256
24	5920-662-180-XX	PLUG	Bouchon	1	*						920662180
25	5920-662-193-XX	PLUG	Bouchon	1	*						920662193

FIG. 6 ELECTRIC – EQUIPMENT
Électricité

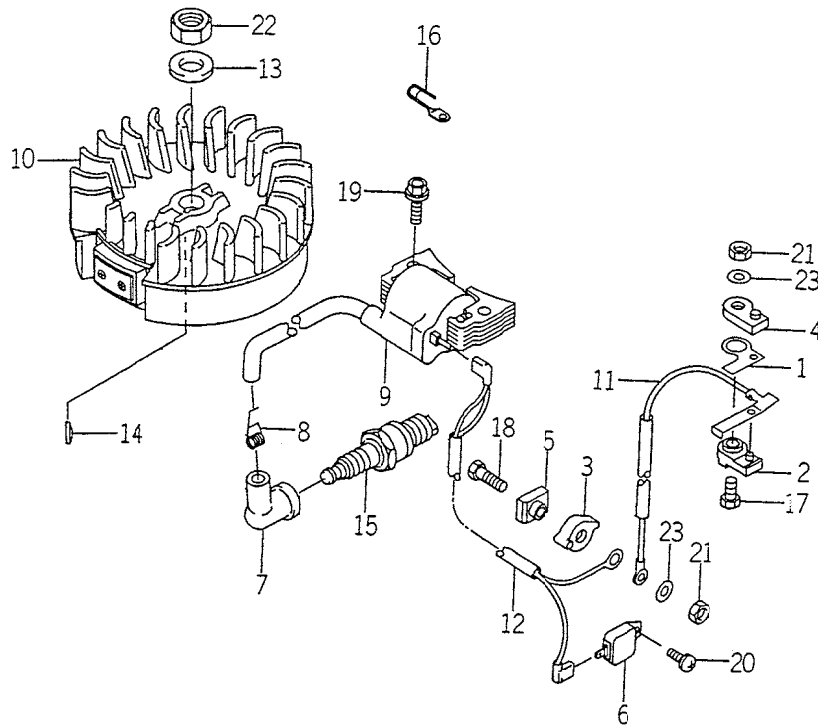

K50C-101

KEY Réf.	PART CODE Pièces No.	DESCRIPTION	Désignation	QTY Quant.	TYPE OF MODEL			I T C	C O L	G R P	REMARKS Remarques
					FC150V EB05	Modél					
1	5131-832-475-XX	PLATE	Praque	1	*						131832475
2	5140-242-182-XX	COVER	Capot	1	*						140242182
3	5140-242-183-XX	COVER	Capot	1	*						140242183
4	5160-732-123-XX	INSULATOR	Ecran thermique	1	*						160732123
5	5160-732-124-XX	INSULATOR	Ecran thermique	1	*						160732124
6	5211-192-139-XX	IGNITER	Bougie d'allumage	1	*						211192139
7	5211-302-066-XX	CAP-SPARK PLUG	Capuchon	1	*						211302366
8	5211-692-004-XX	TERMINAL	Borne	1	*						211692004
9	5211-712-176-XX	COIL-ASSY-IGNITION	Ens. bobine d'allumage	1	*						211712176
10	5211-942-290-XX	FLYWHEEL-COMP	Volant	1	*						211942290
11	5260-112-191-XX	WIRE-LEAD	Fil	1	*						260112191
12	5260-112-279-XX	WIRE-LEAD	Fil	1	*						260112279
13	5920-222-102-XX	WASHER	Rondelle	1	*						90222102
14	5920-382-077-XX	KEY	Clavette	1	*						920382077
15	5920-702-087-XX	PLUG-SPARK, BP5ES (NGK)	Bougie	1	*						920702087
16	5921-702-064-XX	CLAMP	Attache	1	*						921702064
17	5112-B05-16X-XX	BOLT-UPSET	Vis	1	*						112B0516
18	5112-B05-22X-XX	BOLT-UPSETED	Vis	1	*						1112B0522
19	5130-606-25X-XX	BOLT-FLANGED	Vis	2	*						13060625
20	5241-B04-12X-XX	SCREW-PAN-WP+-	Vis	1	*						241B0412
21	5311-B05-00X-XX	NUT-HEX	Ecrou	1	*						311B0500
22	5314-G14-00X-XX	NUT-HEX-FINE	Ecrou	1	*						314G1400
23	5410-B05-00X-XX	W-PLAIN-S	Rondelle	1	*						410B0500

FIG. 7 CONTROL – EQUIPMENT

Commandes

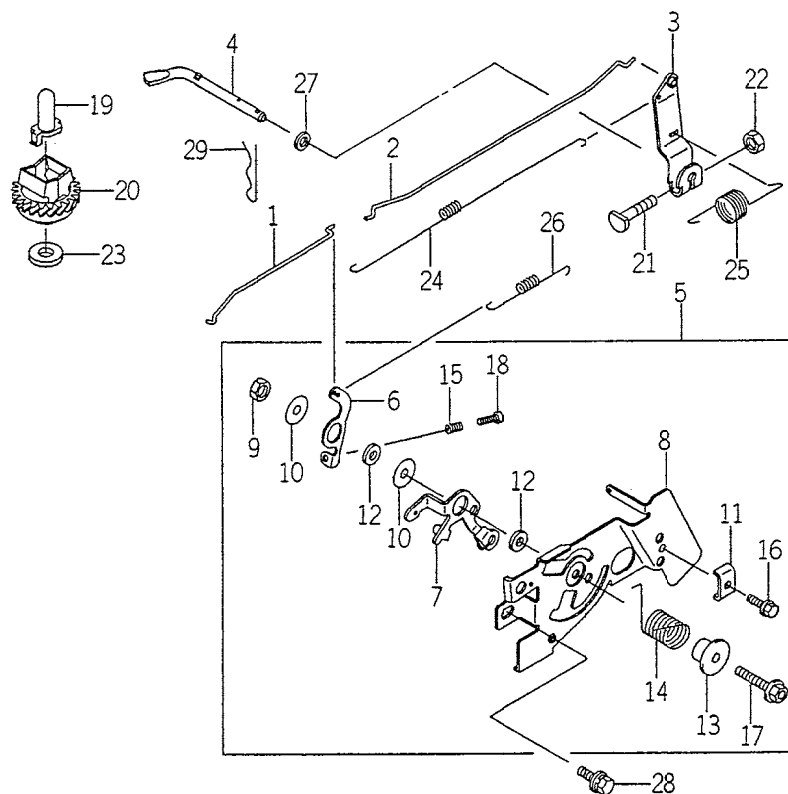

X500-101

KEY Réf.	PART CODE Pièces No.	DESCRIPTION	Désignation	QTY Quant.	TYPE OF MODEL Modél			I T C	C O L	G R P	REMARKS Remarques
					FC150V EB05						
1	5161-692-104-XX	LINK-CHOKE	Tige	1	*						161692104
2	5161-712-060-XX	LINK	Tige	1	*						161712060
3	5211-872-060-XX	ARM-ASSY	Ens. bras	1	*						211872060
4	5390-032-071-XX	ARM-PIVOT	Bras	1	*						390032071
5	5391-802-904-XX	PANEL-ASSY-CONTROL	Ens. panneau de commande	1	*						391802904
6	5131-682-288-XX	LEVER	Levier	1	*						131682288
7	5131-682-298-XX	LEVER	Levier	1	*						131682298
8	5592-262-293-XX	PANEL-CONTROL	Panneau de commande	1	*						592262293
9	5920-152-051-XX	NUT	Ecrou	1	*						920152051
10	5920-222-372-XX	WASHER, 6x19x1.2	Rondelle	2	*						920222372
11	5920-372-209-XX	CLAMP	Attache	1	*						920372209
12	5921-432-135-XX	COLLAR, 6x13x2.3	Entretoise	2	*						921432135
13	5921-432-148-XX	COLLAR	Entretoise	1	*						921432148
14	5921-442-211-XX	SPRING	Ressort	1	*						921442211
15	5921-442-266-XX	SPRING	Ressort	1	*						921442266
16	5921-502-182-XX	BOLT, 5x18	Vis	1	*						921502182
17	5130-B06-30X-XX	BOLT-FLANGED	Vis	1	*						130B0630
18	5214-B04-20X-XX	SCREW-PAN+-	Vis	1	*						214B0420
19	5420-362-051-XX	SLEEVE	Bague	1	*						420362051
20	5491-102-076-XX	GOVERNOR-ASSY	Ens. regulateur	1	*						491102076
21	5920-C22-269-XX	BOLT	Vis	1	*						920022269
22	5920-151-193-XX	NUT	Ecrou	1	*						920151193
23	5920-222-019-00	WASHER	Rondelle	1	*						920222019
24	5920-812-299-XX	SPRING, LINK	Ressort	1	*						920812299
25	5921-442-213-XX	SPRING	Ressort	1	*						921442213

FIG. 8 CARBURETOR

Carburateur

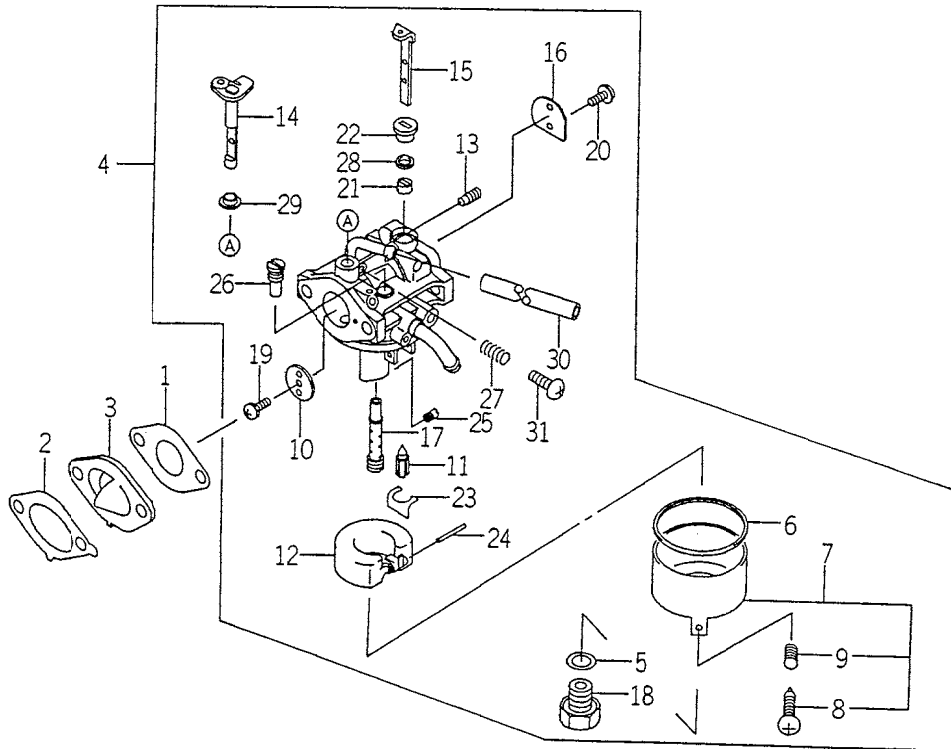

K508-101

KEY Réf.	PART CODE Pièces No.	DESCRIPTION	Désignation	QTY Quant.	TYPE OF MODEL			I T C	C O L	G R P	REMARKS Remarques
					FC150V EB05	Modél					
1	5110-602-010-XX	GASKET, CARBURETOR	Joint	1	*						110602010
2	5110-602-012-XX	GASKET, INSULATOR	Joint	1	*						110602012
3	5160-732-136-XX	INSULATOR	Ecran thermique	1	*						160732136
4	5150-032-364-XX	CARBURETOR-ASSY.	Ens. carburateur	1	*						150032364
5	5110-092-036-XX	GASKET	Joint	1	*						110092036
6	5110-092-037-XX	GASKET	Joint	1	*						110092037
7	5160-202-052-XX	CHAMBER-FLOAT	Chambre du flotteur	1	*						160202052
8	5920-092-015-XX	SCREW	Vis	1	*						920092015
9	5920-812-009-XX	SPRING	Ressort	1	*						920812009
10	5160-252-001-XX	VALVE-THROTTLE, #110	Boisseau	1	*						160252001
11	5160-302-083-XX	VALVE-FLOAT	Soupape	1	*						160302083
12	5160-312-058-XX	FLOAT	Flotteur	1	*						160312058
13	5160-352-063-XX	JET-AIR, #0.9	Vis de richesse	1	*						160352063
14	5160-412-178-XX	SHAFT-CARBURETOR, TH	Axe volet d'air	1	*						160412178
15	5160-412-197-XX	SHAFT-CARBURETOR, CH	Axe volet d'air	1	*						160412197
16	5161-262-199-XX	VALVE	Soupape	1	*						161262199
17	5491-212-189-XX	NOZZLE-MAIN	Gicleur principal	1	*						491212189
18	5920-022-011-XX	BOLT	Vis	1	*						920022011
19	5920-092-024-XX	SCREW	Vis	1	*						920092024
20	5920-092-149-XX	SCREW	Vis	2	*						920092149
21	5920-272-003-XX	COLLAR	Entretoise	1	*						920272003
22	5920-272-004-XX	COLLAR	Entretoise	1	*						920272004
23	5920-332-067-XX	RING-SNAP	Circlips	1	*						920332067
24	5920-432-006-XX	PIN	Axe	1	*						920432006
25	5920-632-096-XX	JET-MAIN, #68.8	Gicleur principal	1	*						920632096

FIG. 9 AIR - FILTER/MUFFLER
Filtre a air/Echappement

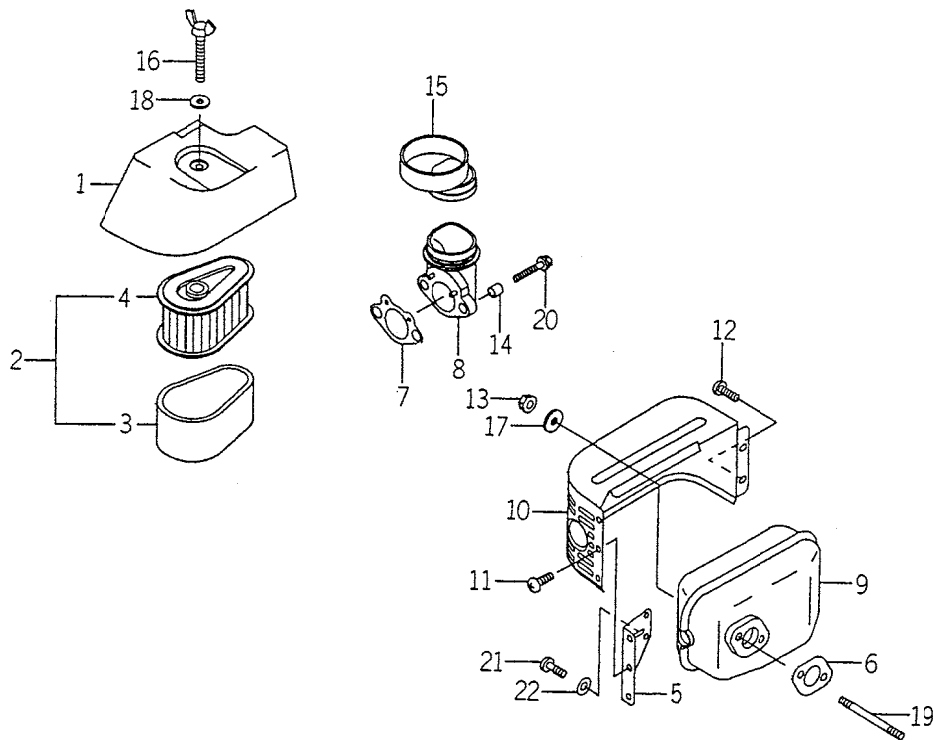

K500-101

KEY Réf.	PART CODE Pièces No.	DESCRIPTION	Désignation	QTY Quant.	TYPE OF MODEL			I T C	C O L	G R P	REMARKS Remarques
					FC150V EB05	Modél					
1	5110-122-313-XX	CAP, AIR FILTER	Capuchon	1	*						110122313
2	5110-292-010X-X	ELEMENT-ASSY-AIR FIL	Ens. element	1	*						110292002
3	5110-132-119-XX	ELEMENT-AIR FILTER	Element	1	*						110132119
4	5110-132-120-XX	ELEMENT-AIR FILTER	Element	1	*						110132120
5	5110-492-002-XX	BRACKET	Support	1	*						110492002
6	5110-602-009-XX	GASKET, MUFFLER	Joint	1	*						110602009
7	5110-602-067-XX	GASKET, INTAKE PIPE	Joint	1	*						110602067
8	5160-602-129-XX	PIPE-INTAKE	Tubulure d'admission	1	*						160602129
9	5490-702-491-XX	MUFFLER-COMP	Echappement	1	*						490702491
10	5491-062-446-XX	COVER-MUFFLER	Couvercle	1	*						491062446
11	5920-092-166-XX	SCREW, 5x8	Vis	3	*						920092166
12	5920-092-308-XX	SCREW	Vis	2	*						920092308
13	5920-151-193-XX	NUT	Ecrou	2	*						920151193
14	5920-262-272-XX	SPACER, 6. 2x7. 8x8	Pièce d'écartement	2	*						920262272
15	5920-592-257-XX	TUBE	Tuyau	1	*						920592257
16	5921-502-101-XX	BOLT	Vis	1	*						921502101
17	5922-002-032-XX	WASHER, 7x21x2. 3	Rondelle	2	*						922002032
18	5922-002-037-XX	WASHER, 6. 5x18x2. 0	Rondelle	1	*						922002037
19	5172-G06-80X-XX	BOLT-STUD	Goujon	2	*						17260680
20	5186-B06-80X-XX	BOLT-UPSET-WP	Vis	2	*						186B0680
21	5214-805-10X-XX	SCREW-PAN+-	Vis	2	*						21480510
22	5411-805-00X-XX	WASHER-PLAIN	Rondelle	2	*						41180500

CHASSIS

FIG. 5 CASE/MISSION SYSTEM
Boitier de transmission

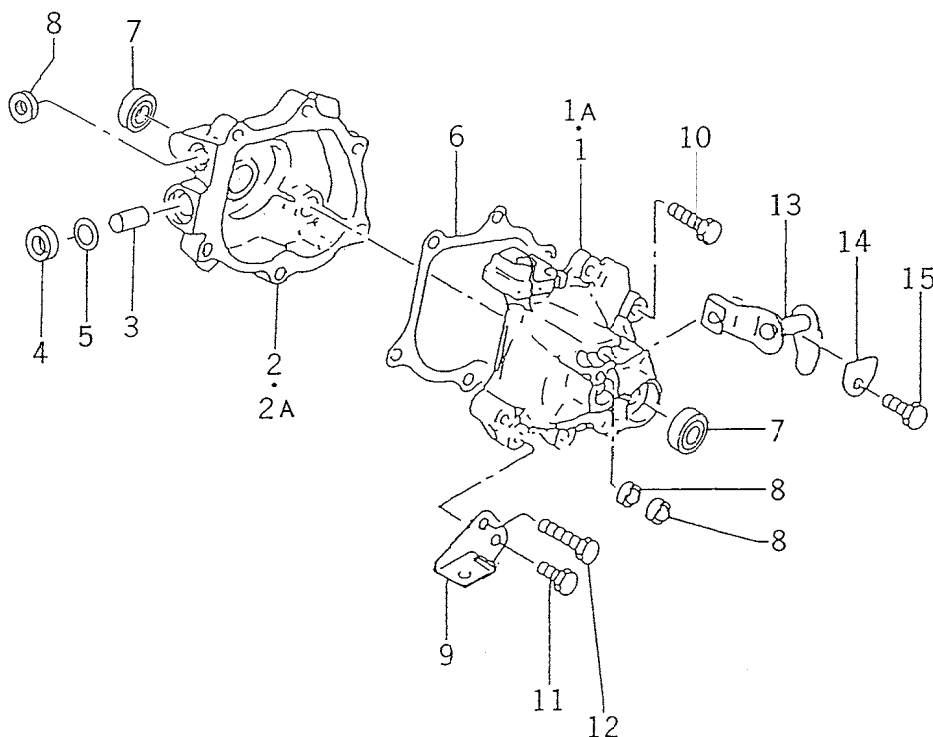

2500-310

KEY Réf.	PART CODE Pièces No.	DESCRIPTION	Désignation	QTY Quant.	TYPE OF MODEL			I T C	C O L	G R P	REMARKS Remarques
					B-B01	E01	GB-GBE01				
1	2500-310-001-00	CASE, MISSION/LH	Boitier	1	1- -102340	1- -102340	1- -102340				
1A	2500-310-001-10	CASE, MISSION/LH	Boitier	1	102341-	102341-	102341-				
2	2500-310-210-00	CASE, MISSION/RH ASSY	Ensemble boitier	1	1- -102340	*	*				
2A	2500-310-210-20	CASE, MISSION ASSY	Ensemble boitier	1	102341-	*	102341-				
3	2500-310-004-00	BUSH/10X12X20	Douille	1	*	*	*				
4	2500-310-008-00	SEAL, OIL	Joint SPI	1	*	*	*				
5	2500-510-006-00	WASHER/11X20X01	Rondelle	1	*	*	*				
6	2500-310-003-00	GASKET	Joint	1	*	*	*				
7	V744-112-220-70	SEAL, OIL	Joint SPI	2	*	*	*				
8	2500-310-009-10	SEAL, OIL	Joint SPI	3	*	*	*				
9	2500-310-005-10	PLATE	Plaque	1	*	*	*				
10	2500-310-006-00	BOLT/TAPPING/06X25	Vis	5	*	*	*				
11	2500-210-005-00	BOLT/TAPPING/6X16	Vis	2	*	*	*				
12	2500-310-012-00	BOLT, TAPPING/06X35	Vis	1	*	*	*				
13	2500-310-200-00	SHIFTER COMP	Fourchette complet	1	*	*	*				
14	2500-310-007-00	HOLDER	Support	1	*	*	*				
15	2500-210-005-00	BOLT/TAPPING/6X16	Vis	1	*	*	*				

FIG. 6 GEAR SYSTEM

Pignonnerie

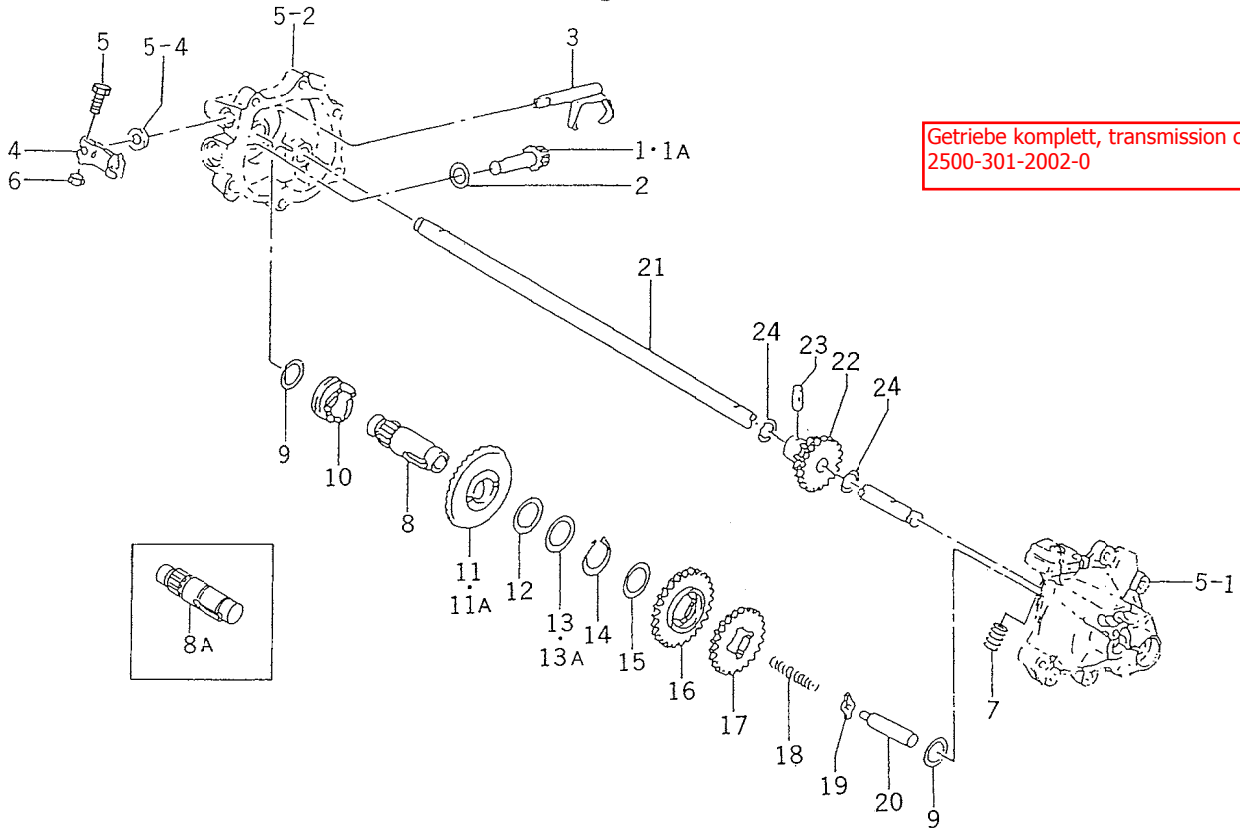

2500-311

KEY Réf.	PART CODE Pièces No.	DESCRIPTION	Désignation	QTY Quant.	TYPE OF MODEL			I T C	C O L	G R P	REMARKS Remarques
					B-801	E01	GB-GBE01				
1	2500-311-001-00	GEAR/BEVEL/14	Pignon	1	1- -300210	1- -300210	1- -300210				
1A	2500-311-001-10	GEAR/BEVEL/14	Pignon	1	300211-	300211-	300211-				
2	2500-510-006-00	WASHER/11X20X01	Rondelle	1	*	*	*				
3	2500-311-200-00	FORK COMP	Fourchette complete	1	*	*	*				
4	2500-311-021-00	ARM/CLUTCH	Bras	1	*	*	*				
5	V200-260-502-00	BOLT	Vis	1	*	*	*				
6	V301-260-005-00	NUT	Ecrou	1	*	*	*				
7	2500-311-015-10	SPRING/HCO39	Ressort	1	*	*	*				
8	2500-311-005-10	SHAFT, INPUT	Arbre d'admission	1	1- -104171	1- -104171	1- -104171				
8A	2500-311-005-20	SHAFT, INPUT	Arbre d'admission	1	104172-	104172-	104172-				
9	2500-311-013-00	WASHER/17X24X01	Rondelle	2	*	*	*				
10	2500-311-003-00	CAM/DRIVE CLUTCH	Cames	1	*	*	*				
11	2500-311-002-00	GEAR/BEVEL/55	Pignon	1	1- -104171	1- -104171	1- -104171				
11A	2500-311-002-10	GEAR/BEVEL/55	Pignon	1	104172-	104172-	104172-				
12	1365-224-002-00	WASHER	Rondelle	2	*	*	*				
13	2500-311-018-00	SHIM/0.5	Cale	1	1- -104171	1- -104171	1- -104171				
13A	2500-311-019-00	SHIM/0.3X20X30	Cale	1	104172-	104172-	104172-				
14	V704-140-020-00	RING, SNAP/20C	Circlips	1	*	*	*				
15	1365-224-002-00	WASHER	Rondelle	1	*	*	*				
16	2500-311-006-00	GEAR/SPAR/30	Pignon	1	*	*	*				
17	2500-311-007-00	GEAR/SPAR/26	Pignon	1	*	*	*				
18	2500-311-016-00	SPRING/HCO48	Ressort	1	*	*	*				
19	2500-311-017-00	CAM, SHIFT	Cames	1	*	*	*				
20	2500-311-008-00	PIN/8X49	Axe	1	*	*	*				
21	2500-311-009-10	SHAFT, WHEEL	Arbre	1	*	*	*				

FIG. 8 WHEEL/REAR SYSTEM
Roue arriere

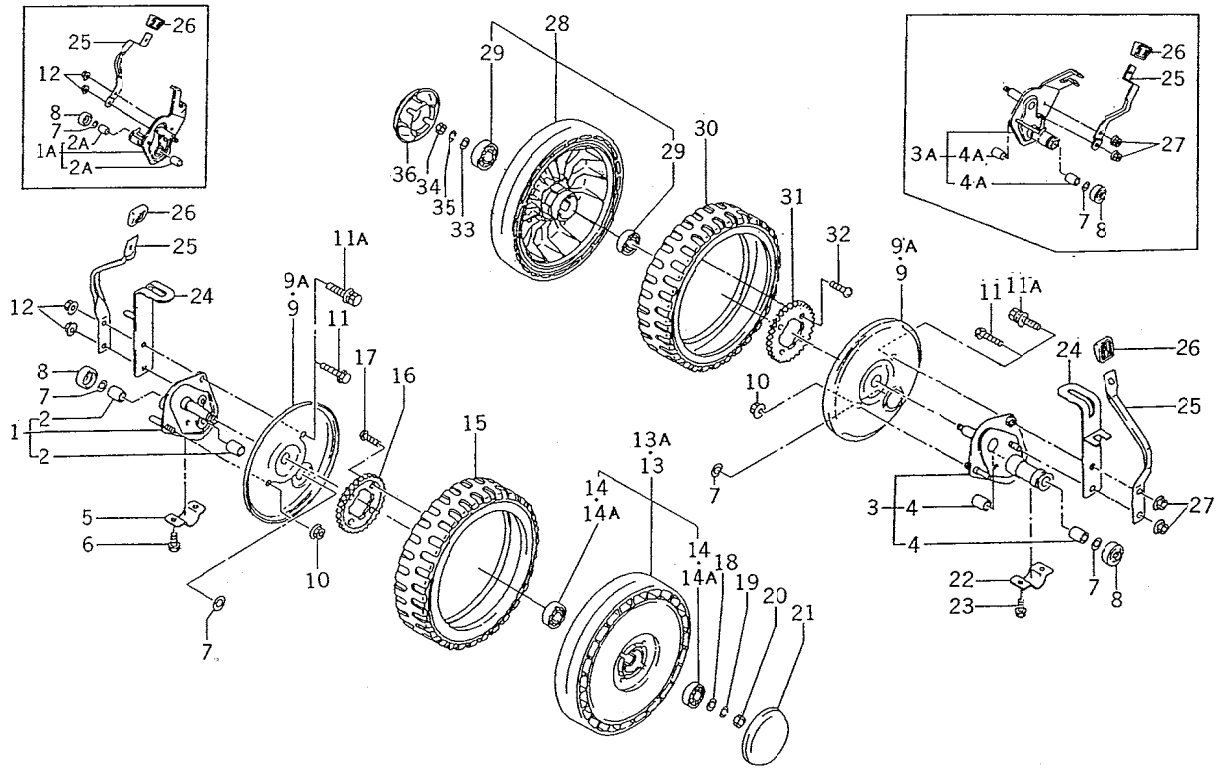

2500-326

KEY Réf.	PART CCDE Pièces No.	DESCRIPTION	Désignation	QTY Quant.	TYPE OF MODEL			I T C	C O L	G R P	REMARKS Remarques
					B-B01	EG1	Modél GB-GBE01				
1	2500-326-240-00	BRACKET/WHEEL/LH	Support	1	1- -104712 104713-	1- -104712 104713-	1- -104712 104713-				
1A	2500-326-240-10	BRACKET/WHEEL/LH	Support	1	1- -104712 104713-	1- -104712 104713-	1- -104712 104713-				
2	3650-440-014-00	BUSH/12X14X20	Douille	2	1- -104712 104713-	1- -104712 104713-	1- -104712 104713-				
2A	2500-376-008-20	BUSH/12X15X20	Douille	2	1- -104712 104713-	1- -104712 104713-	1- -104712 104713-				
3	2500-326-250-00	BRACKET/WHEEL/RH	Support	1	1- -104712 104713-	1- -104712 104713-	1- -104712 104713-				
3A	2500-326-250-10	BRACKET/WHEEL/RH	Support	1	1- -104712 104713-	1- -104712 104713-	1- -104712 104713-				
4	3650-440-014-00	BUSH/12X14X20	Douille	2	1- -104712 104713-	1- -104712 104713-	1- -104712 104713-				
4A	2500-376-008-20	BUSH/12X15X20	Douille	2	1- -104712 104713-	1- -104712 104713-	1- -104712 104713-				
5	2500-326-009-00	HOLDER, BRACKET, WHEEL	Support	2	*	*	*				
6	2500-210-005-00	BOLT/TAPPING/6X16	Vis	4	*	*	*				
7	2500-311-012-00	WASHER/12X21X01	Rondelle	2	*	*	*				
8	2500-326-021-00	CAP	Capuchon	2	*	*	*				
9	2500-326-012-10	COVER, WHEEL	Couvercle	2	1- -104712 104713-	1- -104712 104713-	1- -104712 104713-				
9A	2500-376-012-10	COVER, WHEEL	Couvercle	2	1- -104712 104713-	1- -104712 104713-	1- -104712 104713-				
10	2500-326-017-00	NUT/FLANGE/M06	Ecrou	2	*	*	*				
11	2500-326-019-00	BOLT/FLANGE/M06X25	Vis	2	1- -104712 104713-	1- -104712 104713-	1- -104712 104713-				
11A	V210-360-601-60	BOLT, SP/M6X16	Vis	2	1- -104713	1- 104713-	1- 104713-				
12	2500-326-017-00	NUT/FLANGE/M06	Ecrou	4	*	*	*				
13	2500-326-260-00	RIM, REAR ASSY	Ens. roue arriere	2	1- -104712 104713-	1- -104712 104713-	1- -104712 104713-				
13A	2500-326-260-10	RIM, REAR ASSY	Ens. roue arriere	2	1- -104712 104713-	1- -104712 104713-	1- -104712 104713-				
14	V600-130-620-10	R. B. B.	Roulement	4	1- -104712 104713-	1- -104712 104713-	1- -104712 104713-				
14A	V600-150-620-10	BEARING, RB/6201	Roulement	4	1- -104712 104713-	1- -104712 104713-	1- -104712 104713-				
15	2500-326-006-00	TYRE/9X2	Pneu	2	*	*	*				
16	2500-326-002-00	GEAR, SPUR/42	Pignon	2	*	*	*				
17	2500-326-003-00	SCREW, TAPPING/6X25	Vis	8	*	*	*				

FIG. 8 WHEEL/REAR SYSTEM
Roue arri re

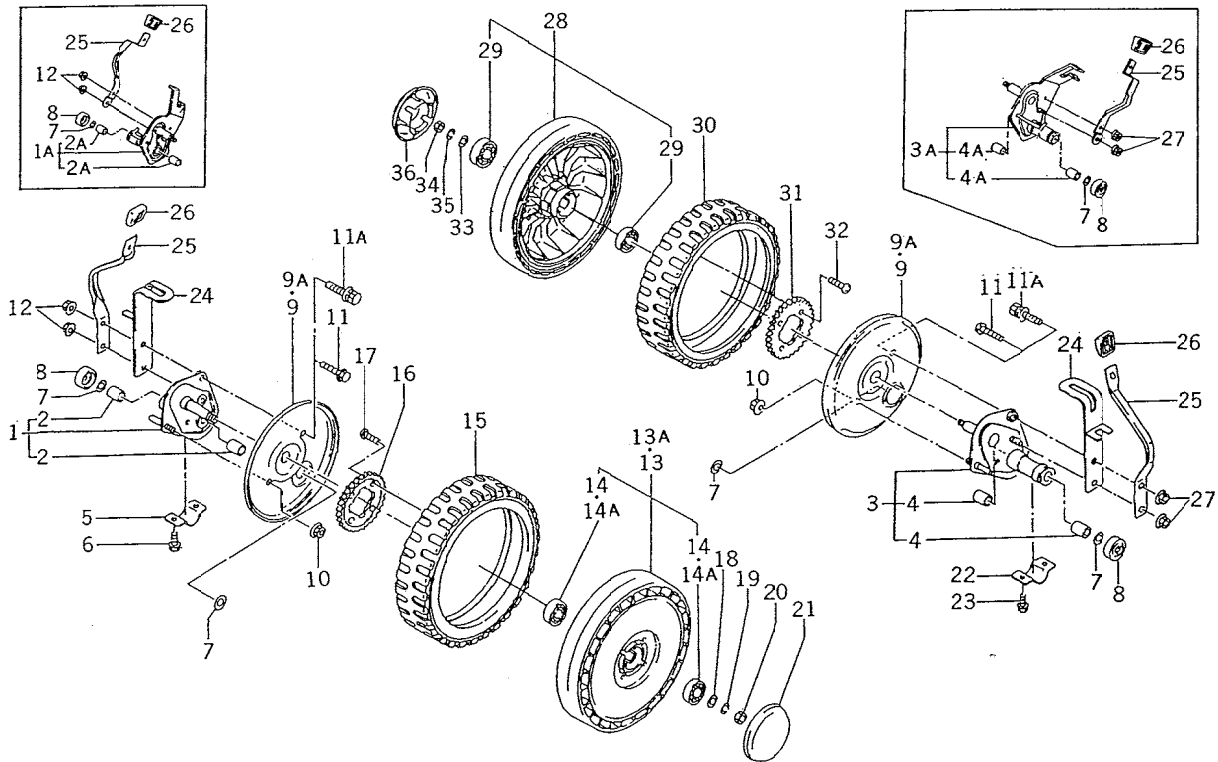

2500-323

KEY R�f.	PART CODE Pi�ces No.	DESCRIPTION	D�signation	QTY Quant.	TYPE OF MODEL			I T C	C O L	G R P	REMARKS Remarques
					B-B01	E01	GB-GBE01				
18	V411-260-008-00	WASHER, PL	Rondelle	2	*	*	*				
19	V401-160-008-00	WASHER, SP/M8	Rondelle frein	2	*	*	*				
20	V304-260-008-00	NUT/M8	Ecrou	2	*	*	*				
21	2500-326-015-00	CAP/WHEEL	Capuchon	2	*	*	*				
22	2500-326-009-10	HOLDER, BRACKET, WHEEL	Support	2	*	*	*				
23	2500-210-005-00	BOLT/TAPPING/6X16	Vis	4	*	*	*				
24	2500-326-230-00	HOLRER, ADJ, HIGH COMP	Composant Qui tent	2	*	*	*				
25	2500-326-013-00	LEVER, SPRING/REAR	Levier	2	*	*	*				
26	2500-326-014-00	GRIP	Poignee	2	*	*	*				
27	2500-326-017-00	NUT/FLANGE/M06	Ecrou	4	*	*	*				
28	2500-326-260-00	RIM, REAR ASSY	Joint arri�re	2	*	*	*				
29	V600-130-620-10	R. B. B.	Roulement	4	*	*	*				
30	2500-326-006-00	TYRE/9X2	Pneu	2	*	*	*				
31	2500-326-002-00	GEAR, SPUR/42	Pignon	2	*	*	*				
32	2500-326-003-00	SCREW, TAPPING/6X25	Vis	8	*	*	*				
33	V411-260-008-00	WASHER, PL	Rondelle	2	*	*	*				
34	V304-260-008-00	NUT/M8	Ecrou	2	*	*	*				
35	V401-160-008-00	WASHER, SP/M8	Rondelle frein	2	*	*	*				
36	2500-326-015-00	CAP/WHEEL	Capuchon	2	*	*	*				

FIG. 9 WHEEL/FRONT SYSTEM
Roue avant

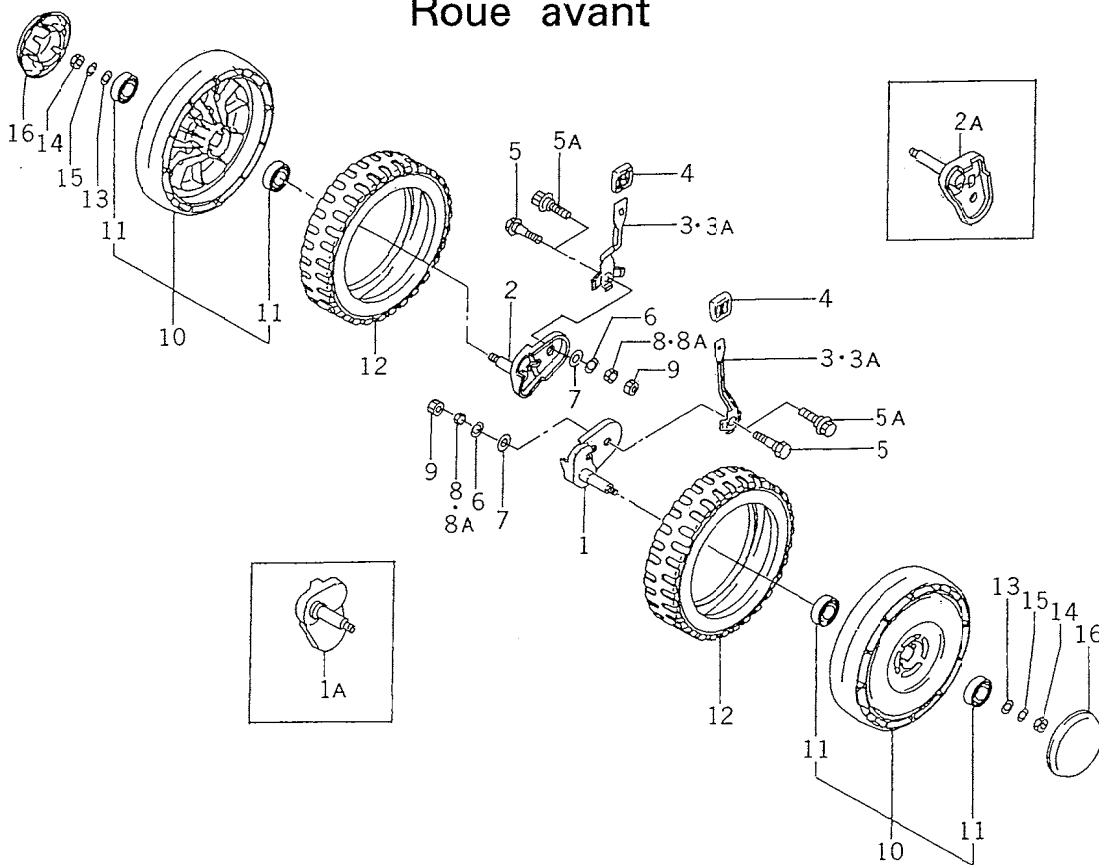

2500-336

KEY Réf.	PART CODE Pièces No.	DESCRIPTION	Désignation	QTY Quant.	TYPE OF MODEL			I T C	C O L	G R P	REMARKS Remarques
					B-301	E01	Modél GB-GBE01				
1	2500-336-200-00	BRACKET, F WHEEL/LH	Support, roue AV. G.	1	1- -104712 104713-	1- -104712 104713-	1- -104712 104713-				
1A	2500-336-200-10	BRACKET/F WHEEL/LH	Support, roue AV. G.	1							
2	2500-336-210-00	BRACKET/F WHEEL/RH	Support, roue AV. D.	1	1- -104712 104713-	1- -104712 104713-	1- -104712 104713-				
2A	2500-336-210-10	BRACKET/F WHEEL/RH	Support, roue AV. D.	1							
3	2500-336-004-00	LEVER/SPRING/FRONT	Levier	2	1- -104712	1- -104712	1- -104712				
3A	2500-386-004-40	LEVER, SPRING, FRONT	Levier	2	1- -104713	104713-	104713				
4	2500-326-014-00	GRIP	Poignee	2	*	*	*				
5	2500-336-002-10	BOLT/M8X30	Vis	2	1- -104712 104713-	1- -104712 104713-	1- -104712 104713-				
5A	2500-386-002-30	BOLT/M08X45	Vis	2							
6	1338-301-005-00	WASHER, RL	Rondelle plate	2	*	*	*				
7	V411-260-008-00	WASHER, PL	Rondelle plate	2	*	*	*				
8	2144-117-002-00	NUT/U/M8	Ecrou	2	1- -104712 104713-	1- -104712 104713-	1- -104712 104713-				
8A	2500-386-001-00	NUT/M08	Ecrou	2							
9	V304-260-008-00	NUT/M8	Ecrou	2	*	*	*				
10	2500-336-260-00	WHEEL/FRONT ASSY	Ens. roue avant	2	*	*	*				
11	V600-150-620-10	BEARING, RB/G201	Roulement a dilles	4	*	*	*				
12	2500-336-006-00	TYRE/8X2	Pneu	2	*	*	*				
13	V411-260-008-00	WASHER, PL	Rondelle	2	*	*	*				
14	V304-260-008-00	NUT/M8	Ecrou	2	*	*	*				
15	V401-160-008-00	WASHER, SP/M8	Rondelle	2	*	*	*				
16	2500-326-015-00	CAP/WHEEL	Capuchon	2	*	*	*				

FIG. 23 LEVER SYSTEM (E01 TYPE)
Levier (modèle E01)

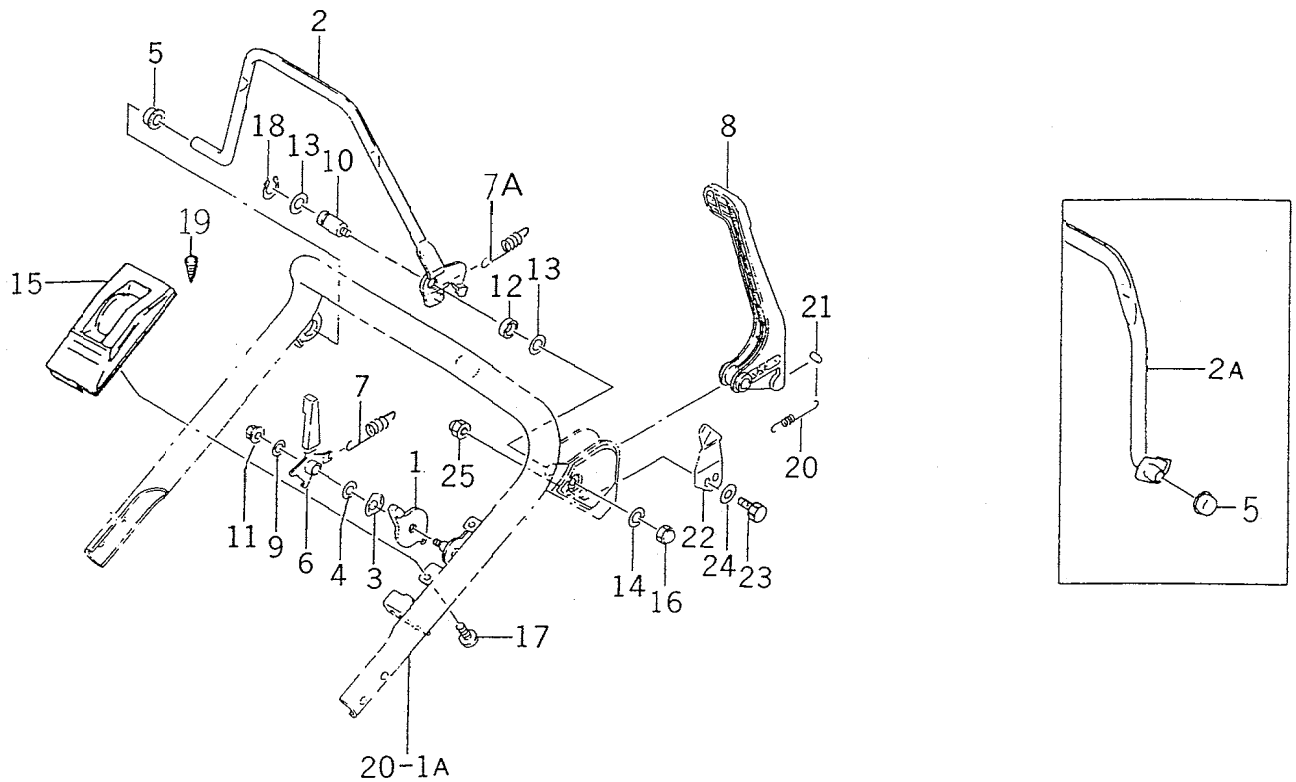

250C-515

KEY Réf.	PART CODE Pièces No.	DESCRIPTION	Désignation	QTY Quant.	TYPE OF MODEL			I T C	C O L	G R P	REMARKS Remarques
					B-601	E01	Modél GB-GBE01				
1	2500-510-011-00	LEVER/AXLE	Levier	1		1- -104712					
2	2500-515-230-10	LEVER/PIPE/E COMP	Levier	1		1- -300000					
2A	2500-560-230-20	LEVER COMP	Levier	1		300001-					
3	2500-510-005-00	SPRING/DISK/10	Ressort	1		1- -104712					
4	2500-510-006-00	WASHER/11X20X01	Rondelle	1		1- -104712					
5	2500-510-013-00	BUSH/14X20X11	Douille	2		*					
6	2500-510-220-00	LEVER/CHANGE COMP	Levier	1		1- -104712					
7	2500-510-051-00	SPRING/HE079	Ressort	1		1- -102340					
7A	2500-510-051-10	SPRING/HE077	Ressort	1		102341-					
8	2500-510-240-10	LEVER/BBC	Levier	1		*					
9	3740-162-005-00	WASHER	Rondelle	1		1- -104712					
10	2503-510-003-20	PIN/14X70	Axe	1		*					
11	2500-326-017-00	NUT/FLANGE/M06	Ecrou	1		1- -104712					
12	2503-510-004-20	COLLAR/15X20X8	Entretoise	1		*					
13	1427-601-003-00	WASHER/15X24X2	Rondelle	2		*					
14	V401-160-008-00	WASHER, SP/M8	Rondelle frein	1		*					
15	2500-510-001-10	COVER/CONTROL	Couvercle	1		1- -104712					
16	V341-120-008-00	NUT, CAP/M8	Ecrou	1		*					
17	2500-510-002-00	SCREW/TAPPING/5X16	Vis	2		1- -104712					
18	V704-140-014-00	RING, SNAP/14C	Circlips	1		*					
19	1527-604-002-00	CLIP	Attache	1		*					
20	2500-515-001-00	SPRING/HE145	Ressort	1		*					
21	2500-210-003-00	PIN/8X14	Axe	1		*					
22	2500-501-002-10	PLATE/SPRING	Plaque	1		*					
23	V200-260-601-00	BOLT	Vis	2		*					

FIG. 27 HARNESS, BATTERY SYSTEM (G TYPE)
Faisceau/batterie (modèle G)

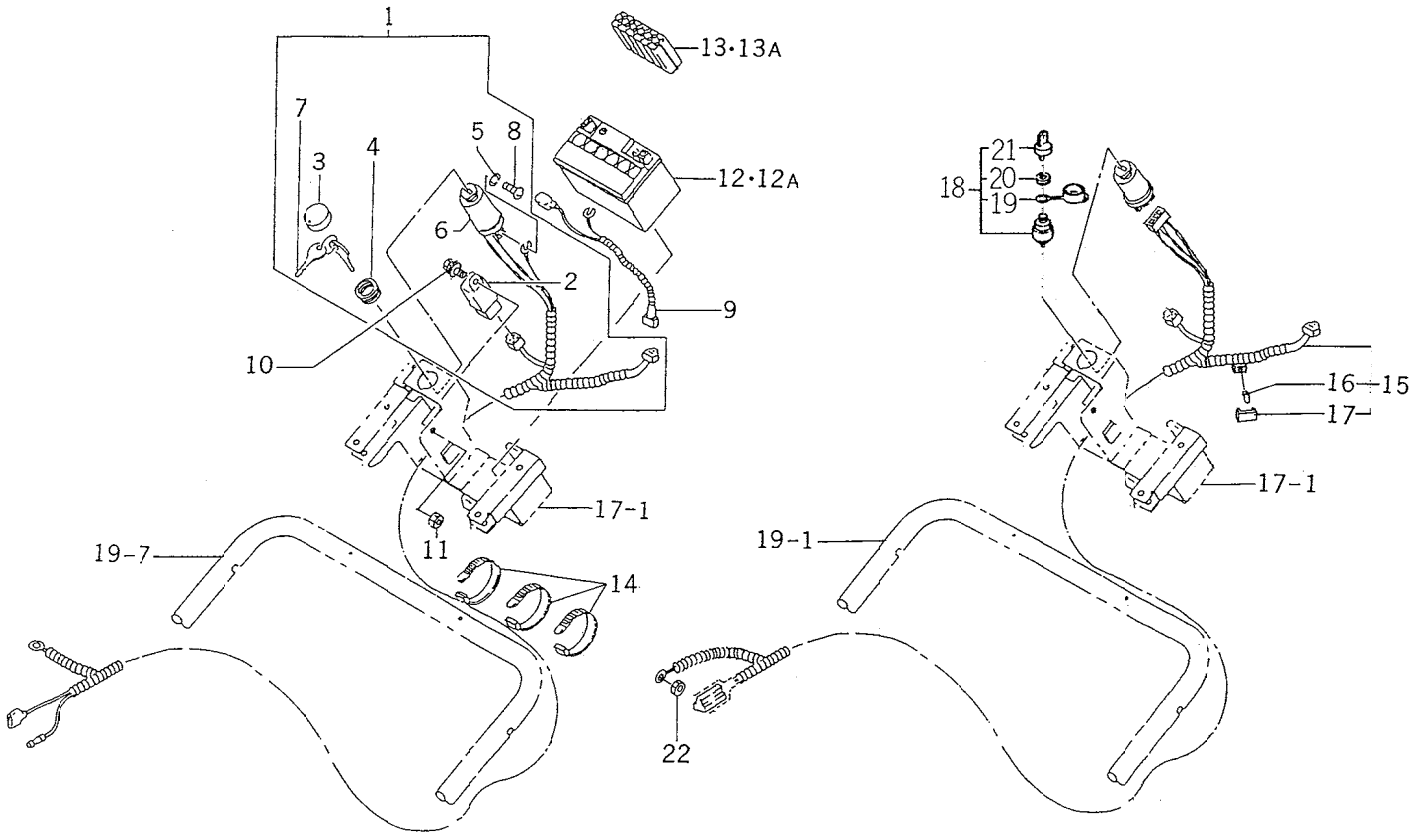

2500-623

KEY Réf.	PART CODE Pièces No.	DESCRIPTION	Désignation	QTY Quant.	TYPE OF MODEL			I T C	C O L	G R P	REMARKS Remarques
					B·B01	E01	GB·GBE01				
1	2500-623-200-40	HARNESS/MAIN ASSY	Faisceau de fils	1			1- -600915				
2	2500-623-220-00	RELAY/4P ASSY	Ens. relais	1			1- -600915				
3	1386-624-292-00	CAP	Capuchon	1			1- -600915				
4	1386-624-293-00	NUT, RING/M22X1.0	Ecrou	1			1- -600915				
5	V401-160-004-00	WASHER, SP/M4	Rondelle frein	3			1- -600915				
6	2500-623-271-00	SWITCH/STATER	Interrupteur	1			1- -600915				
7	1386-624-300-00	SWITCH/KEY ASSY	Cle	1			1- -600915				
8	V111-164-000-60	SCREW/M4X6	Vis	3			1- -600915				
9	2500-623-210-10	HARNESS/BATTERY ASSY	Faisceau de fils	1			*				
10	V210-360-601-20	BOLT, SP/M6X12	Vis	1			*				
11	V301-260-005-00	NUT	Ecrou	1			*				
12	2500-623-230-20	BATTERY SET	Batterie	1			1- -100320				
12A	2500-623-230-30	BATTERY/5 SET	Batterie	1			100321-				
13	2500-623-290-10	CONTAINER ASSY	Ens. reais	1			1- -600915				
13A	2500-623-290-20	CONTAINER/5 ASSY	Ens. reais	1			600916-				
14	1376-402-003-00	BAND/WIRE/140	Bande	3			*				
15	2500-623-200-50	HARNESS/MAIN ASSY	Faisceau de fils	1			600916-				
16	2500-623-201-00	FUSE/BLADE/32V01A	Fusible	1			600916-				
17	3659-836-202-00	COVER/1P FUSE BOX	Couvercle	1			600916-				
18	1105-621-260-00	SWITCH/STARTER/5PSET	Interrupteur	1			600916-				
19	2130-542-231-00	CAP	Capuchon	1			600916-				
20	2130-542-232-00	NUT, RING/M22X1.0	Ecrou	1			600916-				
21	2130-542-240-00	KEY ASSY	Clavette	1			600916-				
22	V301-260-005-00	NUT	Ecrou	1			*				

FIG. 28 HARNESS/BATTERY SYSTEM (GB TYPE)
Faisceau/batterie (modèle GB)

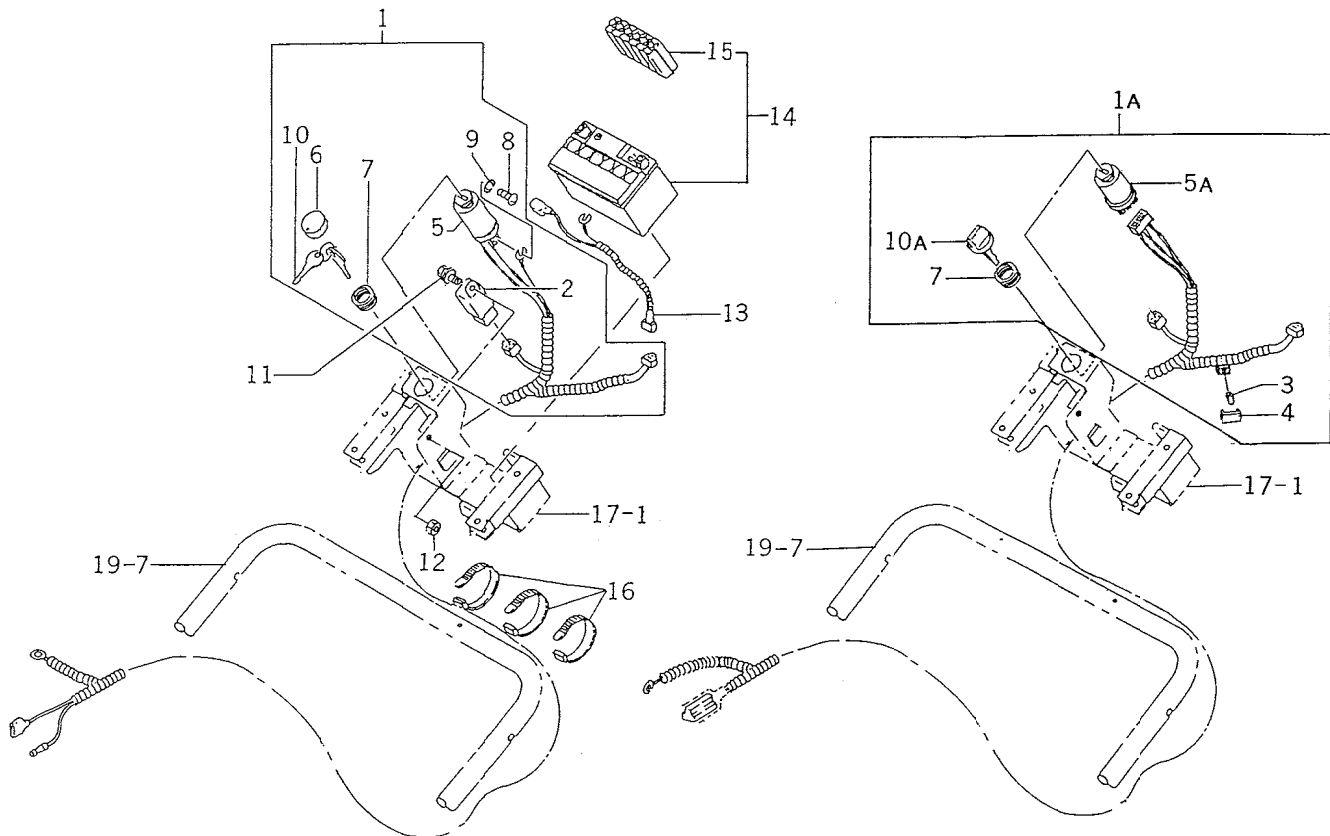

2500-623A

KEY Réf.	PART CODE Pièces No.	DESCRIPTION	Désignation	QTY Quant.	TYPE OF MODEL			I T C	C O L	G R P	REMARKS Remarques
					B-801	E01	Modél GB-GBE01				
1	2500-623-200-40	HARNESS/MAIN ASSY	Faisceau de fils	1			1- -600915 600916-				
1A	2500-623-200-50	HARNESS/MAIN ASSY	Faisceau de fils	1			600916-				
2	2500-623-220-00	RELAY/4P ASSY	Ens. relais	1			*				
3	2500-623-201-00	FUSE/BLADE/32V01A	Fusible	1			*				
4	3659-836-202-00	COVER/1P FUSE BOX	Couvercle	1			*				
5	2500-623-270-00	SWITCH/STARTER ASSY	Intreupteur	1			1- -630915				
5A	1105-621-310-00	SWITCH/STARTER/5P	Intreupteur	1			600916-				
6	1386-624-292-00	CAP	Capuchon	1			*				
7	1386-624-293-00	NUT, RING/M22X1.0	Ecrou	1			*				
8	V111-164-000-60	SCREW/M4X6	Vis	3			*				
9	V401-160-004-00	WASHER, SP/M4	Rondelle	3			*				
10	1386-624-300-00	SWITCH/KEY ASSY	Cle	1			1- -600915 600916-				
10A	213C-542-240-00	KEY ASSY	Clavette	1			600916-				
11	V21C-360-601-20	BOLT, SP/M6X12	Vis	1			*				
12	V301-260-005-00	NUT	Ecrou	1			*				
13	2500-623-210-10	HARNESS/BATTERY ASSY	Faisceau de fils	1			*				
14	2500-623-530-00	BATTERY/J SET	Batterie	1			*				
15	2500-623-590-00	CONTAINER/J ASSY	Ens. relais	1			*				
16	1376-402-003-00	BAND/WIRE/140	Bande	2			*				

FIG. 29 MARK, ORNAMENT, LABEL SYSTEM Etiquettes

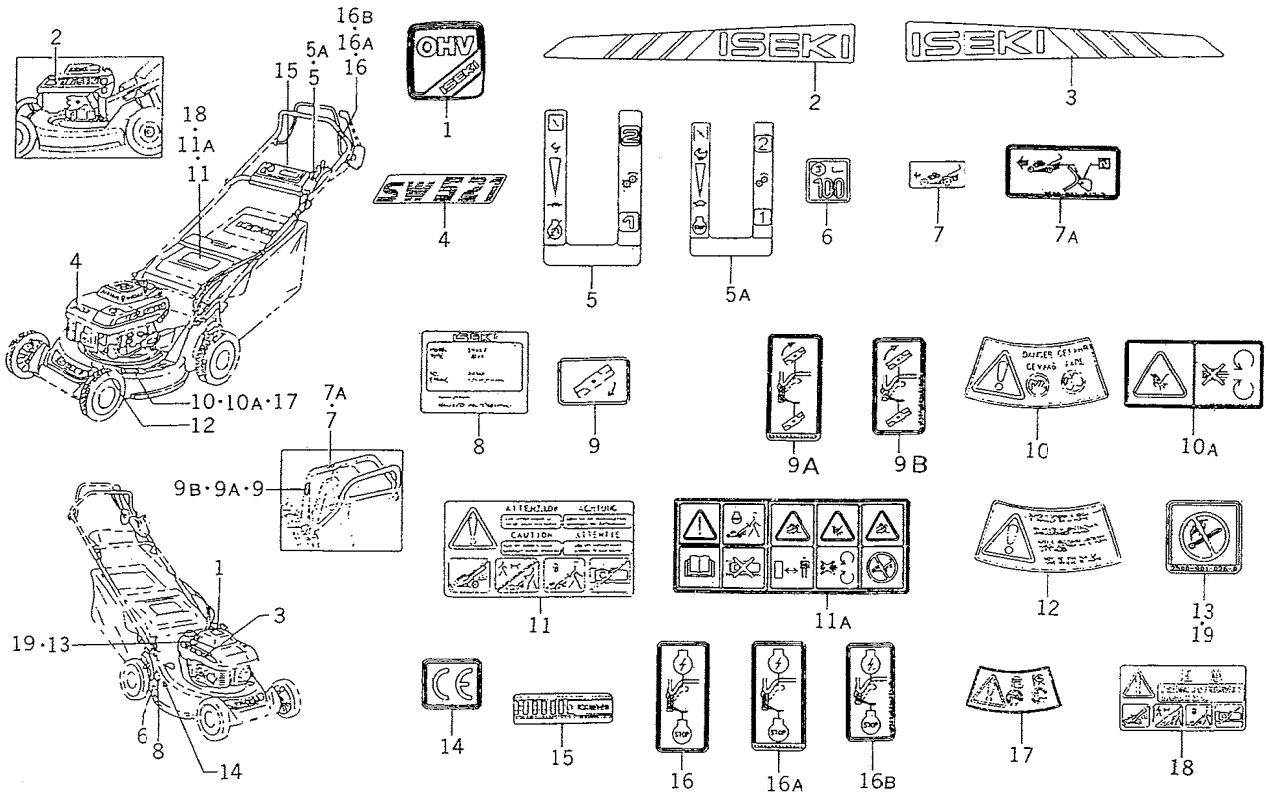

2500-901

KEY Réf.	PART CODE Pièces No.	DESCRIPTION	Désignation	QTY Quant.	TYPE OF MODEL			I T C	C O L	G R P	REMARKS Remarques
					B-801	E01	Modél GB-GBE01				
1	2500-901-001-00	LABEL, ENGINE/TOP	Etiquette	1	*	*	*				
2	2500-901-002-00	LABEL, ENGINE/LH/A	Etiquette	1	*	*	*				
3	2500-901-004-00	LABEL, ENGINE/RH	Etiquette	1	*	*	*				
4	2500-901-005-00	ラベル(SW521)	Etiquette	1	*	*	*				
5	2500-901-007-00	LABEL, CONTROL	Etiquette	1	1- -602240	1- -602240	1- -602240				
5A	2500-901-007-10	LABEL, CONTROL	Etiquette	1	602241-	602241-	602241-				
6	2500-901-008-00	LABEL, NOISE/100	Etiquette	1	*	*	*				
7	2500-901-017-00	LABEL, TRAVEL	Etiquette	1	1- -600240	1- -602240	1- -602240				
7A	2500-901-017-20	LABEL/TRAVEL	Etiquette	1	602241-	602241-	602241-				
8	J910-C00-200-00	LABEL/MODEL ASSY	Etiquette	1	*	*	*				
9	2500-901-018-00	LABEL/BBC	Etiquette	1	1- -300150		1- -300150				
9A	2500-901-018-20	LABEL/BBC	Etiquette	1	300151- -300390		300151- -300390				
9B	2500-901-018-30	LABEL/BBC	Etiquette	1	300391-		300391-				
10	2500-901-014-20	LABEL/DANGER	Etiquette	2	1- -300000	1- -300000	1- -300000				
10A	2500-901-014-30	LABEL/DANGER	Etiquette	2	300001-	300001-	300001-				
11	2500-901-015-20	LABEL/CAUTION	Etiquette	1	1- -300000	1- -300000	1- -300000				
11A	2500-901-015-30	LABEL/CAUTION	Etiquette	1	300001-	300001-	300001-				
12	2500-901-016-20	LABEL/PLUG	Etiquette	1	*	*	*				
13	2500-901-026-00	LABEL	Etiquette	1	*	*	*				
14	2500-901-027-00	LABEL/CE	Etiquette	1	*	*	*				
15	2500-901-013-00	LABEL/SELF	Etiquette	1			*				
16	2500-901-025-00	LABEL/START	Etiquette	1		1- -300150					
16A	2500-901-025-10	LABEL/START	Etiquette	1		300151- -300390					
16B	2500-901-025-20	LABEL/START	Etiquette	1		300391-					
17	2500-907-014-00	LABEL/DANGER/J	Etiquette	2	*		*				

NUMERICAL INDEX

FC150V-AB02.EB02

PART CODE Pièces No.	FIG. KEY Réf No.	PART CODE Pièces No.	FIG. KEY Réf No.	PART CODE Pièces No.	FIG. KEY Réf No.
2500-930-001-00	14 6	5130-086-030-XX	2 3A	5140-242-183-XX	6 1
2500-930-002-00	14 5	5130-246-002-XX	2 15	5140-242-251-XX	5 1
5105-018-162-AX	6 27	5130-256-003-XX	2 16	5140-242-252-XX	5 2
5107-011-225-AX	7 33	5130-256-004-XX	2 17	5140-242-289-XX	5 1A
5110-042-099-XX	1 1	5130-256-013-XX	2 4	5140-902-009-XX	5 1B
5110-086-008-XX	1 39	5130-256-014-XX	2 5	5140-902-013-XX	5 2A
5110-086-023-XX	1 2	5130-272-058-XX	2 18	5140-902-023-XX	5 3
5110-092-036-XX	8 1	5130-292-094-XX	2 6	5144-013-482-AX	6 26
5110-092-037-XX	8 2	5130-292-095-XX	2 7	5144-015-121-BX	7 36
5110-092-346-XX	4 1	5130-372-359-XX	2 19	5144-015-135-AX	7 37
5110-092-740-XX	1 3	5130-372-453-XX	2 8	5144-015-321-BX	7 35
5110-092-742-XX	10 1	5130-702-064-XX	12 2	5144-015-385-AX	7 34
5110-092-743-XX	10 23	5130-702-072-XX	3 6	5144-996-122-AX	9 12
5110-092-746-XX	9 1	5130-702-077-XX	11 4	5144-996-127-AX	9 23
5110-092-770-XX	1 4	5130-702-078-XX	4 2	5144-996-143-AX	9 18
5110-092-831-XX	11 2	5130-912-113-XX	12 3	5144-996-159-AX	9 9
5110-092-833-XX	9 2	5130-B05-10X-XX	1 30	5145-766-130-AX	9 6
5110-092-848-XX	1 5		5 11	5145-986-128-AX	9 10
5110-122-255-XX	12 8		10 27	5145-986-138-AX	9 21
5110-122-272-XX	10 2	5130-B06-10X-XX	11 23	5145-986-157-AX	9 22
5110-122-313-XX	10 2A	5130-B06-12X-XX	1 31	5145-V17-281-AX	1 43
5110-132-119-XX	10 4		11 17	5150-032-006-XX	9 4
5110-132-120-XX	10 5	5130-B06-14X-XX	1 48	5150-032-364-XX	8 5
5110-222-057-XX	1 6	5130-B06-30X-XX	7 13	5154-706-133-AX	9 7
5110-292-002-XX	10 3	5130-G06-25X-XX	1 32	5156-013-452-AX	12 16
5110-462-053-XX	10 6		5 12	5158-014-231-AX	1 47
5110-602-007-XX	1 3A		6 18	5160-202-052-XX	8 6
5110-602-009-XX	10 7	5130-G06-45X-XX	1 33	5160-252-001-XX	8 7
5110-602-010-XX	8 28	5130-G08-45X-XX	1 34	5160-302-083-XX	8 8
5110-602-011-XX	1 4A	5131-072-202-XX	1 7	5160-312-058-XX	8 9
5110-602-012-XX	8 29	5131-072-220-XX	1 8		9 13
5110-602-067-XX	10 1A	5131-162-065-XX	3 7	5160-352-063-XX	8 10
5110-B05-22X-XX	6 29	5131-226-116-00	9 8	5160-412-178-XX	8 11
5112-B05-22X-XX	6 17		9 26		9 14
5117-604-241-00	1 46	5131-652-072-XX	12 4	5160-412-197-XX	8 12
5119-200-900-AX	14 4	5131-682-288-XX	7 2		9 15
5120-042-090-XX	3 1	5131-682-298-XX	7 3	5160-602-129-XX	10 8
5120-052-074-XX	3 2	5131-682-303-XX	11 6	5160-732-124-XX	6 2
5120-092-062-XX	3 3	5131-832-258-XX	1 9	5160-732-136-XX	8 30
5120-162-057-XX	3 4	5131-832-259-XX	1 10		9 3
5120-322-065-XX	3 5	5132-516-025-XX	2 9	5161-042-052-XX	11 7
5127-502-383-00	10 25	5132-516-027-XX	2 10	5161-262-149-XX	1 12
5130-012-109-XX	2 1	5136-506-101-00	9 11	5161-262-150-XX	1 13
5130-022-074-XX	2 2	5140-242-180-XX	1 11	5161-262-173-XX	9 16
5130-086-017-XX	2 3	5140-242-181-XX	5 13	5161-262-199-XX	8 14

PART CODE Pièces No.	FIG. KEY Réf No.	PART CODE Pièces No.	FIG. KEY Réf No.	PART CODE Pièces No.	FIG. KEY Réf No.
5161-692-104-XX	7 30	5391-802-904-XX	7 1A	5705-A04-100-0X	11 19
5161-692-125-XX	7 15	5410-B05-00X-XX	6 22	5920-013-122-XX	2 20
5161-712-060-XX	7 31	5410-B06-00X-XX	7 38	5920-022-011-XX	8 16
5161-712-080-XX	7 16	5411-B05-00X-XX	10 22	5920-022-269-XX	7 21
5164-706-114-00	9 5	5420-362-051-XX	7 19	5920-042-117-XX	5 4
5165-506-137-AX	9 19	5460-752-082-XX	12 6	5920-092-015-XX	8 17
5171-966-812-00	11 21	5490-156-055-XX	1 40	5920-092-024-XX	8 18
5172-708-418-BX	6 23	5490-156-088-XX	1 15	5920-092-104-XX	10 24
5172-708-419-AX	6 24	5490-192-091-XX	11 9	5920-092-149-XX	8 19
5172-C06-80X-XX	10 19	5490-192-094-XX	11 5		9 20
5182-926-656-00	11 20	5490-702-491-XX	10 9	5920-092-166-XX	1 20
5186-B06-80X-XX	10 20	5490-732-055-XX	1 16		10 11
5187-B05-10X-XX	1 35	5490-782-064-XX	3 9	5920-092-280-XX	12 11
5187-B06-14X-XX	7 28	5490-802-143-XX	12 15	5920-092-296-XX	11 8
5210-832-062-XX	1 14	5490-882-379-XX	12 1	5920-092-308-XX	10 12
5211-182-069-XX	3 12	5491-062-446-XX	10 10	5920-151-170-XX	5 5
5211-182-082-XX	3 12A	5491-092-054-XX	11 3	5920-151-193-XX	7 24
5211-192-119-XX	6 3	5491-102-076-XX	7 20		10 13
5211-192-139-XX	6 3A	5491-182-068-XX	3 18	5920-152-051-XX	7 5
5211-302-066-XX	6 4	5491-182-119-XX	3 11	5920-152-240-XX	3 8
5211-692-004-XX	6 5	5491-202-184-XX	1 41	5920-152-241-XX	5 6
5211-692-066-XX	6 6	5491-202-240-XX	1 17	5920-152-253-XX	3 10
5211-712-153-XX	6 7	5491-202-246-XX	1 18	5920-222-019-XX	7 22
5211-712-176-XX	6 7A	5491-212-113-XX	9 17	5920-222-102-XX	6 13
5211-712-200-XX	6 8	5491-212-189-XX	8 15	5920-222-131-XX	1 44
5211-872-060-XX	7 17	5510-012-214-XX	11 10	5920-222-136-XX	5 14
5211-942-186-XX	6 30	5510-482-069-XX	11 1		10 26
5211-942-218-XX	6 9	5520-052-094-XX	4 3	5920-222-372-XX	7 6
5211-942-290-XX	6 10	5551-A06-12X-XX	1 36	5920-222-384-XX	12 12
5214-B04-12X-XX	8 13	5554-A06-00X-XX	7 29	5920-262-272-XX	10 14
	9 29	5560-072-118-XX	14 1	5920-262-273-XX	5 7
5214-B04-20X-XX	7 14	5560-312-375-XX	13 1	5920-262-274-XX	5 8
5214-B05-10X-XX	10 21	5560-312-376-XX	13 2	5920-272-003-XX	8 20
5233-B05-10X-XX	11 18	5560-312-384-XX	13 3	5920-272-004-XX	8 21
5241-B04-12X-XX	6 19	5590-562-726-XX	2 14	5920-332-067-XX	8 22
5260-112-224-XX	6 25	5590-562-790-XX	1 19	5920-332-161-XX	2 12
5260-112-246-XX	6 11		1 42	5920-372-202-XX	11 11
5260-112-279-XX	6 11A	5591-012-079-XX	12 9	5920-372-209-XX	7 8
5260-112-306-XX	6 12	5591-062-115-XX	12 10	5920-382-077-XX	6 14
5311-B05-00X-XX	6 20	5592-262-201-XX	7 4	5920-382-093-XX	2 13
5314-G14-00X-XX	6 21	5592-262-293-XX	7 4A	5920-431-264-XX	1 21
5390-032-066-XX	7 32	5592-312-071-XX	4 4	5920-432-006-XX	8 23
5390-032-071-XX	7 18	5601-B62-05X-XX	1 37	5920-432-168-XX	3 13
5391-082-059-XX	12 5	5670-D20-15X-XX	1 38		3 14
5391-802-549-XX	7 1	5670-D20-16X-XX	4 5	5920-432-169-XX	3 15

FC150V-AB02. EB02

PART CODE Pièces No.	FIG. KEY Réf No.	PART CODE Pièces No.	FIG. KEY Réf No.	PART CODE Pièces No.	FIG. KEY Réf No.
5920-452-155-XX	1 45	5921-902-163-XX	8 4		
5920-492-204-XX	1 22	5922-002-026-XX	1 27		
5920-492-208-XX	1 23	5922-002-029-XX	7 27		
5920-592-256-XX	1 24	5922-002-032-XX	10 17		
5920-592-257-XX	10 15	5922-002-033-XX	1 28		
5920-592-262-XX	11 12	5922-002-034-XX	1 29		
5920-632-096-XX	8 24	5922-002-078-XX	5 10		
	9 24		10 18		
5920-642-002-XX	8 25				
5920-642-065-XX	9 25				
5920-662-180-XX	1 25				
5920-662-193-XX	1 26				
5920-702-081-XX	6 28				
5920-702-084-XX	6 15				
5920-712-109-XX	5 15				
5920-712-113-XX	5 9				
5920-812-009-XX	8 26				
5920-812-265-XX	12 13				
5920-812-299-XX	7 23				
5920-812-342-XX	3 16				
5920-932-087-XX	9 30				
5920-932-088-XX	11 13				
5920-932-101-XX	8 27				
5921-072-057-XX	14 2				
5921-102-093-XX	14 3				
5921-432-135-XX	7 9				
5921-432-143-XX	8 3				
	9 27				
5921-432-148-XX	7 10				
5921-442-176-XX	12 14				
5921-442-177-XX	12 7				
5921-442-211-XX	7 11				
5921-442-213-XX	7 25				
5921-442-235-XX	7 26				
5921-442-266-XX	7 12				
5921-502-101-XX	10 16				
5921-502-102-XX	3 17				
5921-502-122-XX	2 11				
5921-502-182-XX	7 7				
5921-702-009-XX	11 14				
5921-702-020-XX	11 22				
5921-702-037-XX	11 15				
5921-702-041-XX	6 16				
5921-702-043-XX	11 16				
5921-902-003-XX	9 28				

NUMERICAL INDEX

FC150V-AB03.FB03.GB03

PART CODE Pièces No.	FIG. KEY Réf No.	PART CODE Pièces No.	FIG. KEY Réf No.	PART CODE Pièces No.	FIG. KEY Réf No.
2500-930-001-00	16 3	5120-162-057-XX	3 4	5131-652-072-XX	13 6
2500-930-002-00	16 2	5120-162-062-XX	3 4A	5131-682-288-XX	8 6
2921-072-057-XX	16 5	5120-322-065-XX	3 5	5131-682-298-XX	8 7
2921-102-093-XX	16 6	5122-632-079-XX	14 1	5131-682-303-XX	12 9
5105-018-162-AX	6 13	5127-502-883-00	11 14	5131-832-258-XX	1 9
5107-011-225-AX	8 9	5130-012-109-XX	2 1	5131-832-259-XX	1 10
5110-042-099-XX	1 1	5130-022-074-XX	2 2	5132-516-025-XX	2 11
5110-086-008-XX	1 2	5130-086-017-XX	2 3	5132-516-027-XX	2 12
5110-086-023-XX	1 48	5130-086-030-XX	2 17	5132-702-049-XX	1 51
5110-092-036-XX	10 26	5130-246-002-XX	2 4	5132-702-050-XX	1 52
5110-092-037-XX	10 27	5130-256-003-XX	2 5	5136-506-101-00	9 11
5110-092-346-XX	4 1	5130-256-004-XX	2 6	514C-242-180-XX	1 11
5110-092-74C-XX	1 3	5130-256-013-XX	2 18	514C-242-181-XX	5 1
5110-092-742-XX	11 1	5130-256-014-XX	2 19	514C-242-183-XX	6 1
5110-092-743-XX	11 2	5130-272-058-XX	2 7		7 1
5110-092-746-XX	9 1	5130-292-094-XX	2 8	5140-242-251-XX	5 2
5110-092-770-XX	1 4	5130-292-095-XX	2 9	5140-242-252-XX	5 3
5110-092-786-XX	14 2	5130-372-359-XX	2 10	5140-242-289-XX	5 18
5110-092-831-XX	12 4	5130-372-453-XX	2 20	5140-902-009-XX	5 19
5110-092-833-XX	9 2	5130-702-064-XX	13 4	5140-902-013-XX	5 14
5110-092-848-XX	1 5	5130-702-072-XX	3 6	5140-902-023-XX	5 15
5110-122-255-XX	13 3	5130-702-077-XX	12 1	5140-902-074-XX	5 15A
5110-122-272-XX	11 3	5130-702-078-XX	4 2	5144-013-482-AX	6 12
5110-122-313-XX	11 28	5130-912-113-XX	13 5	5144-015-121-BX	8 19
5110-132-119-XX	11 5	5130-B05-10X-XX	1 29	5144-015-135-AX	8 23
5110-132-120-XX	11 6		5 12	5144-015-321-BX	8 13
5110-222-057-XX	1 6		11 19	5144-015-385-AX	8 10
5110-292-002-XX	11 4	5130-B06-10X-XX	12 17	5144-053-092-AX	6 11
5110-462-053-XX	11 7	5130-B06-12X-XX	1 30	5144-996-122-AX	9 12
5110-492-002-XX	11 7A		1 44	5144-996-127-AX	9 23
5110-602-007-XX	1 49		12 22	5144-996-143-AX	9 18
5110-602-009-XX	11 23	5130-B06-14X-XX	1 31	5144-996-159-AX	9 9
5110-602-010-XX	10 29	5130-B06-30X-XX	8 17	5145-766-130-AX	9 6
5110-602-011-XX	1 50	5130-G06-25X-XX	1 32	5145-986-128-AX	9 10
5110-602-012-XX	10 30		5 13	5145-986-138-AX	9 21
5110-602-067-XX	11 1A		6 19	5145-986-157-AX	9 22
5110-B05-22X-XX	6 18		7 24	5145-V17-281-AX	1 21
	7 22	5130-G06-30X-XX	13 22	5150-032-006-XX	9 4
5112-B05-22X-XX	7 23	5130-G06-45X-XX	1 33	5150-032-364-XX	10 1
5117-604-241-00	1 25	5130-G08-45X-XX	1 34	5154-706-133-AX	9 7
5119-200-900-AX	16 1	5131-072-202-XX	1 7	5156-013-452-AX	13 13
5120-042-090-XX	3 1	5131-072-220-XX	1 8	5158-014-231-AX	1 26
5120-052-074-XX	3 2	5131-162-065-XX	3 7	5160-202-052-XX	10 2
5120-092-062-XX	3 3	5131-226-116-00	9 8	5160-252-001-XX	10 3
5120-092-068-XX	3 3A		9 26	5160-302-083-XX	10 4

FC150V-AB03. FB03. GB03

PART CODE Pièces No.	FIG. KEY Réf No.	PART CODE Pièces No.	FIG. KEY Réf No.	PART CODE Pièces No.	FIG. KEY Réf No.
5160-312-058-XX	9 13	5211-692-066-AX	7 6	5490-192-094-XX	12 8
	10 5	5211-692-066-XX	6 5	5490-702-491-XX	11 9
5160-352-063-XX	10 6	5211-712-153-XX	6 7	5490-732-055-XX	1 16
5160-412-178-XX	9 14	5211-712-176-XX	7 7	5490-782-064-XX	3 8
	10 7	5211-712-200-XX	7 8	5490-802-143-XX	13 1
5160-412-197-XX	9 15	5211-742-051-XX	14 4	5490-882-379-XX	13 2
	10 8	5211-872-060-XX	8 3	5491-062-446-XX	11 10
5160-602-129-XX	11 8	5211-932-086-XX	6 8	5491-092-054-XX	12 6
5160-732-124-XX	6 2	5211-932-151-XX	7 9	5491-102-076-XX	8 20
	7 2	5214-B04-12X-XX	9 29	5491-102-081-XX	8 40
5160-732-136-XX	9 3		10 25	5491-182-068-XX	3 9
	10 28	5214-B04-20X-XX	8 18	5491-182-119-XX	3 18
5161-042-052-XX	12 10	5214-B05-10X-XX	11 27	5491-202-185-XX	1 18
5161-262-149-XX	1 12	5223-B04-06X-XX	14 9	5491-202-225-XX	1 39
5161-262-150-XX	1 13	5223-D05-16X-XX	14 10	5491-202-247-XX	1 17
5161-262-173-XX	9 16	5224-B06-25X-XX	6 20	5491-212-113-XX	9 17
5161-262-199-XX	10 9		7 25	5491-212-189-XX	10 10
5161-262-201-XX	1 53	5233-B05-10X-XX	12 18	5510-012-214-XX	12 2
5161-262-202-XX	1 54	5241-B04-12X-XX	6 21	5510-482-069-XX	12 3
5161-462-156-XX	14 3		7 26	5520-052-094-XX	4 3
5161-692-104-XX	8 1	5260-112-209-XX	14 5	5551-A06-12X-XX	1 36
5161-692-125-XX	8 38	5260-112-210-XX	14 6	5552-B10-12X-XX	13 23
5161-712-060-XX	8 2	5260-112-224-XX	6 9		14 14
5161-712-080-XX	8 34	5260-112-279-XX	7 10	5554-A06-00X-XX	8 29
5164-706-114-00	9 5	5260-112-283-XX	13 19	5560-072-118-XX	16 4
5165-506-137-AX	9 19	5260-112-306-XX	7 11	5560-312-375-XX	15 1
5171-966-812-00	12 12	5311-B05-00X-XX	6 22	5560-312-376-XX	15 2
5172-708-418-BX	6 4		7 27	5560-312-384-XX	15 3
5172-708-419-AX	6 6	5314-G14-00X-XX	6 23	5560-312-447-XX	15 4
5172-G06-80X-XX	11 20		7 28	5590-312-076-XX	6 10
5182-926-656-00	12 5	5315-501-312-2A	2 15		7 12
5186-B06-80X-XX	11 21	5390-032-066-XX	8 4	5590-312-110-XX	7 13
5187-BC5-10X-XX	1 35	5390-032-071-XX	8 30	5590-562-726-XX	2 14
5187-BC6-14X-XX	8 27	5391-082-059-XX	13 7	5590-562-790-XX	1 19
5187-GC6-35X-XX	14 13	5391-802-549-XX	8 5	5591-012-079-XX	13 9
5210-832-062-XX	1 14	5391-802-904-XX	8 39	5591-062-115-XX	13 10
5211-182-069-XX	3 10	5410-B05-00X-XX	6 24	5592-212-128-XX	14 7
5211-182-082-XX	3 10A		7 29	5592-262-201-XX	8 8
5211-182-090-XX	3 10B	5410-B06-00X-XX	8 28	5592-262-293-XX	8 41
5211-192-119-XX	6 3	5411-B05-00X-XX	11 22	5592-312-071-XX	4 4
5211-192-139-XX	7 3	5420-362-051-XX	8 35	5601-B62-05X-XX	1 47
5211-302-066-XX	7 4	5460-752-082-XX	13 8	5670-D20-15X-XX	1 37
5211-632-100-XX	13 17	5490-156-055-XX	1 15	5670-D20-16X-XX	4 5
5211-632-117-XX	13 18	5490-156-088-XX	1 38	5705-A04-100-0X	12 19
5211-692-004-XX	7 5	5490-192-091-XX	12 7	5920-022-011-XX	10 11

PART CODE Pièces No.	FIG. KEY Réf No.	PART CODE Pièces No.	FIG. KEY Réf No.	PART CODE Pièces No.	FIG. KEY Réf No.
5920-022-269-XX	8 21	5920-431-264-XX	1 23	5921-502-182-XX	8 31
5920-042-117-XX	5 4	5920-432-006-XX	10 18	5921-702-009-XX	12 15
	5 14	5920-432-168-XX	3 11	5921-702-020-XX	12 16
5920-042-118-XX	5 5		3 17	5921-702-029-XX	7 20
5920-092-015-XX	10 12	5920-432-169-XX	3 12	5921-702-037-XX	12 21
5920-092-024-XX	10 13	5920-452-155-XX	1 24	5921-702-043-XX	12 20
5920-092-104-XX	11 11	5920-492-204-XX	1 42	5921-702-064-XX	7 21
5920-092-149-XX	9 20	5920-492-208-XX	1 43	5921-902-003-XX	9 28
	10 14	5920-592-256-XX	1 27	5921-902-068-XX	12 23
5920-092-166-XX	1 20	5920-592-257-XX	11 17	5921-902-163-XX	10 24
	11 12	5920-592-261-XX	13 21	5922-002-026-XX	1 46
5920-092-280-XX	13 11		14 12	5922-002-029-XX	8 37
5920-092-281-XX	14 8	5920-592-262-XX	12 14	5922-002-032-XX	11 25
5920-092-296-XX	12 11	5920-632-096-XX	9 24	5922-002-033-XX	1 40
5920-092-307-XX	7 14		10 19	5922-002-034-XX	1 41
5920-092-308-XX	11 24	5920-642-002-XX	10 20	5922-002-078-XX	5 16
5920-151-170-XX	5 6	5920-642-065-XX	9 25		11 26
5920-151-193-XX	8 22	5920-662-180-XX	1 28		
	11 13	5920-662-193-XX	1 45		
	13 20	5920-702-081-XX	6 16		
	14 11	5920-702-084-XX	7 17		
5920-152-051-XX	8 32	5920-702-087-XX	7 18		
5920-152-240-XX	3 14	5920-712-109-XX	5 11		
5920-152-241-XX	5 7	5920-712-113-XX	5 17		
5920-152-253-XX	3 15	5920-712-122-XX	6 17		
5920-222-019-XX	8 36		7 19		
5920-222-102-XX	7 15	5920-812-009-XX	10 21		
5920-222-131-XX	1 22	5920-812-265-XX	13 16		
5920-222-136-XX	5 8	5920-812-299-XX	8 24		
	11 15	5920-812-342-XX	3 13		
5920-222-372-XX	8 11	5920-932-088-XX	12 24		
5920-222-384-XX	13 12	5920-932-101-XX	10 22		
5920-262-272-XX	11 16	5921-432-135-XX	8 14		
5920-262-273-XX	5 9	5921-432-143-XX	9 27		
5920-262-274-XX	5 10		10 23		
5920-272-003-XX	10 15	5921-432-148-XX	8 15		
5920-272-004-XX	10 16	5921-442-176-XX	13 14		
5920-332-067-XX	10 17	5921-442-177-XX	13 15		
5920-332-161-XX	2 21	5921-442-211-XX	8 16		
5920-372-104-XX	6 14	5921-442-213-XX	8 25		
5920-372-202-XX	12 13	5921-442-235-XX	8 26		
5920-372-209-XX	8 12	5921-442-266-XX	8 33		
5920-382-077-XX	6 15	5921-502-101-XX	11 18		
	7 16	5921-502-102-XX	3 16		
5920-382-093-XX	2 16	5921-502-122-XX	2 13		

NUMERICAL INDEX

FC150V-EB05

PART CODE Pièces No.	FIG. KEY Réf No.	PART CODE Pièces No.	FIG. KEY Réf No.	PART CODE Pièces No.	FIG. KEY Réf No.
5110-042-099-XX	1 1		10 18	5187-B05-10X-XX	1 34
5110-086-023-XX	1 2	5130-B06-30X-XX	7 17	5187-B06-14X-XX	7 28
5110-092-036-XX	8 5	5130-G06-25X-XX	1 31	5210-832-062-XX	1 14
5110-092-037-XX	8 6		5 13	5211-182-090-XX	3 10
5110-092-346-XX	4 1		6 19	5211-192-139-XX	6 6
5110-092-831-XX	10 9	5130-G06-45X-XX	1 32	5211-302-066-XX	6 7
5110-092-848-XX	1 3	5130-G08-45X-XX	1 33	5211-692-0C4-XX	6 8
5110-122-255-XX	11 3	5131-072-202-XX	1 7	5211-712-176-XX	6 9
5110-122-313-XX	9 1	5131-072-220-XX	1 8	5211-872-060-XX	7 3
5110-132-119-XX	9 3	5131-162-065-XX	3 7	5211-942-290-XX	6 10
5110-132-120-XX	9 4	5131-652-072-XX	11 6	5214-B04-12X-XX	8 31
5110-222-057-XX	1 4	5131-682-288-XX	7 6	5214-B04-2CX-XX	7 18
5110-292-002-XX	9 2	5131-682-298-XX	7 7	5214-B05-10X-XX	9 21
5110-482-028-XX	12 1	5131-682-303-XX	10 4	5233-B05-10X-XX	10 19
5110-492-002-XX	9 5	5131-832-475-XX	6 1	5241-B04-12X-XX	6 20
5110-602-007-XX	1 5	5132-516-025-XX	2 9	5260-112-191-XX	6 11
5110-602-009-XX	9 6	5132-516-027-XX	2 10	5260-112-279-XX	6 12
5110-602-010-XX	8 1	5132-702-049-XX	1 9	5311-B05-00X-XX	6 21
5110-602-011-XX	1 6	5132-702-050-XX	1 10	5314-G14-00X-XX	6 22
5110-602-012-XX	8 2	5140-242-18C-XX	1 11	5390-032-071-XX	7 4
5110-602-067-XX	9 7	5140-242-182-XX	6 2	5391-082-059-XX	11 7
5112-B05-16X-XX	6 17	5140-242-183-XX	6 3	5391-802-904-XX	7 5
5112-B05-22X-XX	6 18	5140-902-009-XX	5 1	5391-872-053-XX	12 2
5120-042-095-XX	3 1	5140-902-013-XX	5 2	5410-B05-00X-XX	6 23
5120-052-084-XX	3 2	5140-902-023-XX	5 3		12 9
5120-092-068-XX	3 3	5150-032-364-XX	8 4	5411-B05-00X-XX	9 22
5120-162-057-XX	3 4	5160-202-052-XX	8 7	5420-362-051-XX	7 19
5120-322-065-XX	3 5	5160-252-001-XX	8 10	5430-012-054-XX	12 3
5130-012-109-XX	2 1	5160-302-083-XX	8 11	5460-752-082-XX	11 8
5130-022-074-XX	2 4	5160-312-058-XX	8 12	5482-L40-00X-XX	12 10
5130-086-030-XX	2 5	5160-352-063-XX	8 13	5490-156-088-XX	1 15
5130-256-013-XX	2 6	5160-412-178-XX	8 14	5490-192-091-XX	10 2
5130-256-014-XX	2 7	5160-412-197-XX	8 15	5490-192-094-XX	10 3
5130-292-094-XX	2 2	5160-602-129-XX	9 8	5490-702-491-XX	9 9
5130-292-095-XX	2 3	5160-732-123-XX	6 4	5490-732-055-XX	1 16
5130-372-453-XX	2 8	5160-732-124-XX	6 5	5490-782-064-XX	3 8
5130-702-064-XX	11 4	5160-732-136-XX	8 3	5490-802-143-XX	11 1
5130-702-072-XX	3 6	5161-042-052-XX	10 5	5490-882-364-XX	11 2
5130-702-077-XX	10 1	5161-262-199-XX	8 16	5491-062-446-XX	9 10
5130-702-078-XX	4 2	5161-262-201-XX	1 12	5491-092-054-XX	10 10
5130-912-113-XX	11 5	5161-262-202-XX	1 13	5491-102-076-XX	7 20
5130-B05-10X-XX	1 29	5161-692-104-XX	7 1	5491-182-119-XX	3 9
	5 12	5161-712-060-XX	7 2	5491-202-240-XX	1 17
5130-B06-10X-XX	12 8	5172-G06-80X-XX	9 19	5491-212-189-XX	8 17
5130-B06-12X-XX	1 30	5186-B06-80X-XX	9 20	5510-012-214-XX	10 7

PART CODE Pièces No.	FIG. KEY Réf No.	PART CODE Pièces No.	FIG. KEY Réf No.	PART CODE Pièces No.	FIG. KEY Réf No.
5510-482-069-XX	10 8	5920-332-067-XX	8 23		12 7
5520-052-094-XX	4 3	5920-332-161-XX	2 13	5921-702-009-XX	10 14
5550-D20-10X-XX	12 11	5920-372-202-XX	10 11	5921-702-037-XX	10 15
5551-A06-12X-XX	1 35	5920-372-209-XX	7 11	5921-702-043-XX	10 16
5554-A06-00X-XX	7 29		12 4	5921-702-054-XX	6 16
5560-072-118-XX	14 1	5920-382-077-XX	6 14	5921-902-058-XX	10 17
5560-312-375-XX	13 1	5920-382-093-XX	2 14	5921-902-153-XX	8 30
5560-312-447-XX	13 2	5920-431-264-XX	1 20	5922-002-026-XX	1 26
5590-562-726-XX	2 12	5920-432-006-XX	8 24	5922-002-029-XX	7 27
5590-562-790-XX	1 18	5920-432-168-XX	3 11	5922-002-032-XX	9 17
5591-012-079-XX	11 9	5920-432-170-XX	12 5	5922-002-033-XX	1 27
5591-062-110-XX	11 10	5920-452-204-XX	1 21	5922-002-034-XX	1 28
5592-262-293-XX	7 8	5920-492-208-XX	1 22	5922-002-037-XX	5 11
5592-312-071-XX	4 4	5920-592-256-XX	1 23		9 18
5601-B62-05X-XX	1 36	5920-592-257-XX	9 15		
5670-D20-15X-XX	1 37	5920-592-262-XX	10 12		
5670-D20-16X-XX	4 5	5920-632-096-XX	8 25		
5920-C22-011-XX	8 18	5920-642-002-XX	8 26		
5920-C22-269-XX	7 21	5920-662-180-XX	1 24		
5920-C42-117-XX	5 4	5920-662-193-XX	1 25		
5920-042-119-XX	5 5	5920-702-087-XX	6 15		
5920-092-015-XX	8 8	5920-712-113-XX	5 10		
5920-092-024-XX	8 19	5920-812-009-XX	8 9		
5920-092-149-XX	8 20		8 27		
5920-092-166-XX	1 19	5920-812-265-XX	11 13		
5920-092-280-XX	9 11	5920-812-299-XX	7 24		
5920-092-296-XX	11 11	5920-812-342-XX	3 12		
5920-092-308-XX	10 6	5920-932-088-XX	10 13		
5920-151-170-XX	9 12	5920-932-101-XX	8 28		
	5 6	5921-072-057-XX	14 2		
5920-151-193-XX	7 22	5921-102-093-XX	14 3		
	9 13	5921-432-135-XX	7 12		
5920-152-051-XX	7 9	5921-432-143-XX	8 29		
5920-152-240-XX	3 13	5921-432-148-XX	7 13		
5920-152-241-XX	5 7	5921-442-176-XX	11 14		
5920-152-253-XX	3 14	5921-442-177-XX	11 15		
5920-222-019-00	7 23	5921-442-211-XX	7 14		
5920-222-102-XX	6 13	5921-442-213-XX	7 25		
5920-222-372-XX	7 10	5921-442-235-XX	7 26		
5920-222-384-XX	11 12	5921-442-266-XX	7 15		
5920-262-272-XX	9 14	5921-442-351-XX	12 6		
5920-262-273-XX	5 8	5921-502-101-XX	9 16		
5920-262-274-XX	5 9	5921-502-102-XX	3 15		
5920-272-003-XX	8 21	5921-502-122-XX	2 11		
5920-272-004-XX	8 22	5921-502-182-XX	7 16		

NUMERICAL INDEX

2500-098-100-10

PART CODE Pièces No.	FIG. KEY Réf No.	PART CODE Pièces No.	FIG. KEY Réf No.	PART CODE Pièces No.	FIG. KEY Réf No.
1105-621-260-00	27 18	2500-210-006-10	2 15	2500-311-003-00	6 10
1105-621-310-00	28 5A	2500-210-008-00	2 16	2500-311-004-00	6 23
1328-601-004-00	3 6		23 21	2500-311-005-10	6 8
1338-301-005-00	9 6	2500-210-016-00	2 6	2500-311-005-20	6 8A
1365-224-002-00	6 12	2500-210-017-00	2 7	2500-311-006-00	6 16
	6 15	2500-210-202-00	2 9	2500-311-007-00	6 17
1376-121-001-00	2 8	2500-210-203-00	2 10	2500-311-008-00	6 20
1376-402-003-00	24 5	2500-210-301-00	2 2	2500-311-009-10	6 21
	24 8	2500-210-302-00	2 3	2500-311-011-10	6 22
	27 14	2500-210-303-00	2 4	2500-311-012-00	6 24
	28 16	2500-210-310-00	2 1		7 8
1386-624-292-00	27 3	2500-215-001-00	3 1		8 7
	28 6	2500-215-002-00	3 2	2500-311-013-00	6 9
1386-624-293-00	27 4		30 6	2500-311-015-10	6 7
	28 7	2500-215-003-00	3 3	2500-311-016-00	6 18
1386-624-300-00	27 7	2500-215-004-00	1 1	2500-311-017-00	6 19
	28 10		1 6	2500-311-018-00	6 13
1425-621-004-00	16 5	2500-220-001-00	3 5	2500-311-019-00	6 13A
	18 3	2500-260-310-10	2 1A	2500-311-021-00	6 4
	19 3	2500-265-001-30	3 5A	2500-311-200-00	6 3
	24 4	2500-265-014-00	30 7	2500-312-002-00	7 1
1427-601-003-00	21 14	2500-302-200-00	4 1	2500-312-003-00	7 3
	23 13	2500-302-203-00	4 2	2500-312-004-10	7 4
	25 4	2500-302-204-00	4 3	2500-312-005-10	7 5
1527-604-002-00	23 19	2500-302-206-00	4 4	2500-312-008-10	7 2
1560-601-017-00	14 3	2500-302-207-00	4 5	2500-312-200-00	7 6
2130-542-231-00	27 19	2500-302-208-00	4 6	2500-326-002-00	8 16
2130-542-232-00	27 20	2500-302-209-00	4 7		8 31
2130-542-240-00	27 21	2500-310-001-00	5 1	2500-326-003-00	8 17
	28 10A	2500-310-001-10	5 1A		8 32
2144-117-002-00	9 8	2500-310-003-00	5 6	2500-326-006-00	8 15
2500-101-001-00	1 2A	2500-310-004-00	5 3		8 30
2500-151-001-00	1 2B	2500-310-005-10	5 9	2500-326-009-00	8 5
	1 7	2500-310-006-00	5 10	2500-326-009-10	8 22
2500-210-001-00	2 11	2500-310-007-00	5 14	2500-326-012-10	8 9
	3 4	2500-310-008-00	5 4	2500-326-013-00	8 25
2500-210-002-00	2 13	2500-310-009-10	5 8	2500-326-014-00	8 26
2500-210-004-20	2 12	2500-310-012-00	5 12		9 4
2500-210-005-00	2 14	2500-310-200-00	5 13	2500-326-015-00	8 21
	5 11	2500-310-210-00	5 2		8 36
	5 15	2500-310-210-20	5 2A		9 16
	8 6	2500-311-001-00	6 1	2500-326-017-00	8 10
	8 23	2500-311-001-10	6 1A		8 12
	11 9A	2500-311-002-00	6 11		8 27
	13 5	2500-311-002-10	6 11A		21 7

PART CODE Pièces No.	FIG. KEY Réf No.	PART CODE Pièces No.	FIG. KEY Réf No.	PART CODE Pièces No.	FIG. KEY Réf No.
2500-326-019-00	22 7	2500-451-007-10	11 7A	2500-510-002-00	17 11
2500-326-021-00	23 11	2500-451-007-20	11 7B		21 9
2500-326-230-00	8 11	2500-501-002-10	14 10		22 9
	8 8		23 22		23 17
	8 24	2500-501-003-00	15 2	2500-510-003-00	25 12
2500-326-240-00	8 1	2500-501-003-10	16 4	2500-510-003-10	25 12A
2500-326-240-10	8 1A		18 2	2500-510-005-00	21 2
2500-326-250-00	8 3		19 2		22 2
2500-326-250-10	8 3A	2500-501-006-00	16 3		23 3
2500-326-260-00	8 13		17 7	2500-510-006-00	5 5
2500-326-260-10	8 28	2500-501-011-10	14 11		6 2
2500-336-002-10	8 13A	2500-501-013-00	14 2		10 7
2500-336-004-00	9 5	2500-501-019-00	14 6		21 3
2500-336-006-00	9 3		14 8		22 3
	9 12		20 2		23 4
2500-336-200-00	9 1	2500-501-021-20	16 1	2500-510-011-00	21 1
2500-336-200-10	9 1A	2500-501-022-00	14 7		22 1
2500-336-210-00	9 2		14 9		23 1
2500-336-210-10	9 2A		16 11	2500-510-013-00	21 11
2500-336-260-00	9 10		17 8		23 5
2500-352-200-10	10 1		18 9		25 8
2500-352-202-00	10 3		19 9	2500-510-015-00	25 13A
2500-376-008-20	8 2A		20 3	2500-510-051-00	23 7
	8 4A	2500-501-041-10	14 12	2500-510-051-10	21 5A
2500-376-012-10	8 9A	2500-501-210-20	14 1		21 12A
2500-386-001-00	9 8A	2500-501-210-30	14 1A		22 5
2500-386-002-30	9 5A	2500-501-210-40	14 1B		23 7A
2500-386-004-40	9 3A	2500-501-220-00	15 1		25 10
2500-401-002-00	11 4	2500-502-002-20	17 3	2500-510-220-00	21 4
2500-401-003-00	11 5	2500-502-002-30	19 7		22 4
2500-401-006-00	11 3	2500-502-003-00	17 4		23 6
	11 6	2500-502-004-00	17 9	2500-510-230-10	21 10
	11 9	2500-502-005-10	17 10	2500-510-240-00	21 13
	12 2	2500-502-005-20	17 10A		25 9
	12 4	2500-502-008-00	17 2	2500-510-240-10	23 8
2500-401-007-00	11 7	2500-502-200-10	17 1		25 9A
2500-401-009-00	12 1	2500-502-220-00	16 2	2500-510-410-00	25 11
2500-401-011-00	11 1		18 1	2500-510-410-10	25 11A
2500-401-011-10	11 1A		19 1	2500-515-001-00	23 20
2500-401-012-00	11 2	2500-502-250-00	18 7	2500-515-230-10	23 2
2500-401-014-00	11 10	2500-505-210-30	20 1	2500-520-0C1-10	24 1
2500-420-001-00	13 1	2500-505-210-40	20 1A	2500-520-0C2-10	24 2
2500-420-003-00	13 2	2500-510-001-10	21 8	2500-520-0C3-10	24 3
2500-420-004-00	13 3		22 8	2500-520-0C6-00	24 6
2500-420-005-00	13 4		23 15	2500-520-0C7-00	24 7

2500-098-100-10

PART CODE Pièces No.	FIG. KEY Réf No.	PART CODE Pièces No.	FIG. KEY Réf No.	PART CODE Pièces No..	FIG. KEY Réf No.
2500-552-002-20	16 9	2500-901-025-20	29 16B	V301-260-005-00	6 6
2500-560-230-20	23 2A	2500-901-026-00	29 13		27 11
	25 1		29 19		27 22
2500-607-001-00	26 2	2500-901-027-00	29 14		28 12
2500-607-002-00	26 3	2500-907-014-00	29 17	V304-260-008-00	8 20
2500-607-200-00	26 1	2500-907-015-00	29 18		8 34
2500-607-300-00	26 4	2500-930-001-00	30 1		9 9
2500-623-200-40	27 1	2500-930-002-00	30 2		9 14
	28 1	2500-931-001-00	30 5		15 3
2500-623-200-50	27 15	2500-931-210-00	30 3		17 5
2500-623-201-00	28 1A	2500-932-210-00	30 9	V304-260-010-00	1 5
	27 16	2500-990-001-00	30 10		30 8
	28 3	2500-991-001-10	30 11	V340-120-006-00	14 5
2500-623-210-10	27 9	2500-991-001-20	30 11A		14 13
	28 13	2503-302-201-10	10 2		23 25
2500-623-220-00	27 2	2503-302-203-10	10 4	V341-120-008-00	15 4
	28 2	2503-302-204-10	10 5		16 8
2500-623-230-20	27 12	2503-510-003-20	23 10		18 6
2500-623-230-30	27 12A		25 2		19 6
2500-623-270-00	28 5	2503-510-004-20	23 12		23 16
2500-623-271-00	27 6		25 3		25 6
2500-623-290-10	27 13	3650-440-014-00	7 7	V401-160-004-00	27 5
2500-623-290-20	27 13A		8 2		28 9
2500-623-530-00	28 14		8 4	V401-160-003-00	8 19
2500-623-590-00	28 15	3659-836-202-00	27 17		8 35
2500-901-001-00	29 1		28 4		9 15
2500-901-002-00	29 2	3737-172-011-00	1 3		15 5
2500-901-004-00	29 3	3740-162-005-00	11 8		16 7
2500-901-005-00	29 4		21 6A		17 6
2500-901-007-00	29 5		22 6		18 5
2500-901-007-10	29 5A		23 9		19 5
2500-901-008-00	29 6	3768-172-008-00	12 3		23 14
2500-901-013-00	29 15	J910-000-200-00	29 8		25 5
2500-901-014-20	29 10	V111-164-000-60	27 8	V401-160-010-00	1 4
2500-901-014-30	29 10A		28 8		3 8
2500-901-015-20	29 11	V200-260-502-00	6 5	V411-260-006-00	23 24
2500-901-015-30	29 11A	V200-260-601-00	23 23	V411-260-008-00	2 5
2500-901-016-20	29 12	V203-361-002-00	3 7		8 18
2500-901-017-00	29 7	V203-361-003-00	30 4		8 33
2500-901-017-20	29 7A	V210-160-601-00	14 4		9 7
2500-901-018-00	29 9	V210-360-601-00	14 4A		9 13
2500-901-018-20	29 9A	V210-360-601-20	27 10		15 6
2500-901-018-30	29 9B		28 11		16 6
2500-901-025-00	29 16	V210-360-601-60	8 11A		16 10
2500-901-025-10	29 16A	V211-661-005-00	1 2		18 4

ALPHABETICAL INDEX

FC150V-AB02.EB02

DESCRIPTION	FIG. KEY	DESCRIPTION	FIG. KEY
6 21ANGED	6 29	COVER	1 11
0 RING	4 5	COVER	6 1
0-RING	1 38	COVER	5 1
ARM	1 14	COVER	5 3
ARM-ASSY	7 17	COVER-CRANKCASE	1 15
ARM-PIVOT	7 18	COVER-LOWER	5 2
ARM-PIVOT	7 32	COVER-LOWER	5 2A
ARM-ROCKER	3 4	COVER-MUFFLER	10 10
BOLT	8 16	COVER-UPPER	5 1A
BOLT	7 21	COVER-UPPER	5 1B
BOLT	10 16	CAMSHAFT-COMP	3 11
BOLT	3 17	CAMSHAFT-COMP	3 18
BOLT-5X18	7 7	CAP-AIR FILTER	10 2
BOLT-CONNECTING ROD	2 11	CAP-AIR FILTER	10 2A
BOLT-FLANGED	1 30	CAP-ASSY-TANK	11 1
BOLT-FLANGED	5 11	CAP-GRIP	12 8
BOLT-FLANGED	1 31	CAP-SPARK PLUG	6 23
BOLT-FLANGED	11 17	CAP-SPARK PLUG	6 4
BOLT-FLANGED	7 13	CARBURETOR-ASSY	8 5
BOLT-FLANGED	1 32	CARBURETOR-ASSY.	9 4
BOLT-FLANGED	5 12	CASE-ROCKER	1 6
BOLT-FLANGED	6 18	CHAMBER-FLOAT	8 6
BOLT-FLANGED	1 33	CHAMBER-FLOAT	9 6
BOLT-FLANGED	1 34	CLAMP	6 27
BOLT-STUD	10 19	CLAMP	11 21
BOLT-UPSET	6 17	CLAMP	11 11
BOLT-UPSET-WP	10 20	CLAMP	7 8
BOLT-UPSET-WSP	1 35	CLAMP	11 14
BOLT-UPSET-WSP	7 28	CLAMP	11 22
BEARING-BALL	1 37	CLAMP	11 15
BEARING-BALL	1 45	CLAMP	6 16
BOLT	7 33	CLAMP	11 16
BOLT	9 18	COLLAR	9 21
BOLT-FLANGED	10 27	COLLAR	9 22
BOLT-FLANGED	11 23	COLLAR	9 27
BOLT-FLANGED	1 48	COVER	5 13
BRACKET	10 6	COVER-CRANKCASE	1 40
COIL-ASSY-IGNITION	6 7	CRANKCASE-COMP	1 17
COIL-ASSY-IGNITION	6 7A	CRANKCASE-COMP	1 18
COIL-ASSY-IGNITION	6 8	CRANKCASE-COMP	1 41
COLLAR	8 20	CRANKSHAFT	2 19
COLLAR	8 21	CRANKSHAFT	2 8
COLLAR	8 3	DECOMPRESSOR	3 12
COLLAR	7 10	DECOMPRESSOR	3 12A
COLLAR-6X13X2.3	7 9	ELEMENT BREATHER	11 3

DESCRIPTION	FIG. KEY	DESCRIPTION	FIG. KEY
ELEMENT-AIR FILTER	10 4	HOLDER-RECOIL	12 3
ELEMENT-AIR FILTER	10 5	HEAD-COMP-CYLINDER	1 39
ELEMENT-ASSY	10 3	HEAD-COMP-CYLINDER	1 2
ELEMENT-BREATHER	11 20	IGNITER	6 3
FILLER	4 4	IGNITER	6 3A
<hr/>			
FILTER-COMP	11 7	INSULATOR	6 2
FILTER-FUEL	11 9	INSULATOR	8 30
FILTER-FUEL	11 5	INSULATOR	9 3
FLOAT	8 9	JET-AIR 0. 9	8 10
FLOAT	9 13	JET-MAIN 68. 8	8 24
<hr/>			
FLYWHEEL-COMP	6 9	JET-MAIN, #68. 8	9 24
FLYWHEEL-COMP	6 10	JET-PILOT 45	8 25
FLYWHEEL-COMP	6 30	JET-PILOT, #38. 8	9 25
GOVERNOR-ASSY	7 20	KEY	6 14
GASKET	8 1	KEY	2 13
<hr/>			
GASKET	8 2	LABEL-MANUAL	13 1
GASKET	11 2	LABEL-MANUAL	13 2
GASKET	9 9	LABEL-MANUAL	13 3
GASKET	9 10	LEVER	7 2
GASKET HEAD	1 1	LEVER	7 3
<hr/>			
GASKET, CARBURETOR	9 1	LEVER	11 6
GASKET, INSULATOR	9 2	LINK	7 31
GASKET, MUFFLER	10 23	LINK	7 16
GASKET-OIL GAUGE	4 1	LINK-CHOKE	7 15
GASKET-COVER	1 3	LINK-CHOKE	7 30
<hr/>			
GASKET-COVER	1 3A	MUFFLER-COMP	10 9
GASKET-CARBURETOR	8 28	NOZZLE-MAIN	8 15
GASKET-CRANKCASE	1 4	NOZZLE-MAIN, #2A	9 17
GASKET-CRANKCASE	1 4A	NUT	7 34
GASKET-INSULATOR	8 29	NUT	5 5
<hr/>			
GASKET-INTAKE PIPE	10 1	NUT	7 24
GASKET-INTAKE PIPE	10 1A	NUT	10 13
GASKET-MUFFLER	10 7	NUT	7 5
GASKET-ROCKER	1 5	NUT	3 8
GAUGE-CIL	4 3	NUT	3 10
<hr/>			
GEAR-HELICAL	2 14	NUT-6MM	5 6
GEAR-HELICAL	1 19	NUT-HEX	6 20
GEAR-HELICAL	1 42	NUT-HEX-FINE	6 21
GROMMET	5 9	PANEL-ASSY-CONTROL	7 1
GRIP-RECOIL STARTER	12 6	PANEL-ASSY-CONTROL	7 1A
<hr/>			
GROMMET	5 15	PANEL-CONTROL	7 4
GUIDE	3 6	PANEL-CONTROL	7 4A
GUIDE	11 4	PAWL-RECOIL STARTER	12 4
GUIDE	4 2	PIN	9 23
GUIDE-ROPE	12 2	PIN	1 21

FC150V-AB02. EB02

DESCRIPTION	FIG. KEY	DESCRIPTION	FIG. KEY
PIN	8 23	SCREW-5X18	12 11
PIN	3 13	SCREW-5X8	1 20
PIN	3 14	SCREW-5X8	10 11
PIN	3 15	SCREW-PAN	8 13
PIN-DOWEL	1 36	SCREW-PAN	7 14
PIN-PISTON	2 2	SCREW-PAN	10 21
PIN-SNAP	7 29	SCREW-PAN+-	9 29
PIPE-INTAKE	10 8	SCREW-PAN-WP	11 18
PISTON-ENGINE	2 1	SCREW-PAN-WP	6 19
PISTON-ENGINE-0.25	2 6	SCREW-PILOT AIR	9 5
PISTON-ENGINE-0.50	2 7	SEAL	9 30
PISTON-ENGINE 0.75	2 18	SEAL	11 13
PLATE	1 9	SEAL	8 27
PLATE	1 10	SEAL-OIL	1 22
PLUG	1 25	SEAL-OIL	1 23
PLUG	1 26	SEAL-OIL	1 46
PLUG-SPARK, BP5ES (NGK)	6 28	SEAL-OIL	1 47
PLUG-SPARK-BP6ES	6 15	SHAFT	1 7
PULLEY-STARTING	12 15	SHAFT	1 8
ROD-ASSY-CONNECTING	2 9	SHAFT-CARBURETOR	8 11
ROD-ASSY-CONNECTING	2 10	SHAFT-CARBURETOR	8 12
ROD-PUSH	3 7	SHAFT-CARBURETOR, CH	9 15
ROPE-3. 8X1600	12 10	SHAFT-CARBURETOR, TH	9 14
REEL-RECOIL-STARTER	12 9	SLEEVE	7 36
RETAINER-SPRING	12 5	SLEEVE	7 19
RETAINER-VALVE	3 3	SLINGER-OIL	1 16
RING-SET-PISTON	2 3	SPACER-6. 2X7. 8X17	5 7
RING-SET-PISTON	2 3A	SPACER-6. 2X7. 8X22	5 8
RING-SET-PISTONL	2 4	SPACER-6. 2X7. 8X8	10 14
RING-SET-PISTONL	2 5	SPRING	9 8
RING-SET-PISTON 0.25	2 16	SPRING	9 26
RING-SET-PISTON 0.50	2 17	SPRING	7 35
RING-SET-PISTON 0.75	2 15	SPRING	8 26
RING-SNAP	2 20	SPRING	3 16
RING-SNAP	8 22	SPRING	12 14
RING-SNAP	2 12	SPRING	7 11
SCREW	9 7	SPRING	7 25
SCREW	9 19	SPRING	7 26
SCREW	8 17	SPRING	7 12
SCREW	8 18	SPRING, RECOIL	12 16
SCREW	10 24	SPRING-ENGINEVALVE	3 9
SCREW	8 19	SPRING-LINK	7 23
SCREW	9 20	SPRING-RECOIL	12 13
SCREW	11 8	SPRING-RETURN	12 7
SCREW	10 12	STARTER-RECOIL	12 1

DESCRIPTION	FIG. KEY	DESCRIPTION	FIG. KEY
STUD	5 4	WASHER-6X12X1.6	1 29
TOOL-DRIVER	14 2	WASHER-6X19X1.2	7 6
TOOL-WRENCH-19X21	14 3	WASHER-7X21X2.3	10 17
TOOLKIT	14 1	WASHER-PLAIN	10 22
TANK-COMP-FUEL	11 10	WIRE-LEAD	6 25
TAPPET	3 5	WIRE-LEAD	6 11
TERMINAL	6 24	WIRE-LEAD	6 11A
TERMINAL	6 5	WIRE-LEAD	6 12
TERMINAL	6 6		
TOOL KIT	14 4		
TOOL-DRIVER	14 5		
TOOL-WRENCH, 19x21	14 6		
TUBE	1 24		
TUBE	10 15		
TUBE	11 12		
TUBE, 5x8x125	9 28		
TUBE-4X7X125	8 4		
TUBE-BRAID	11 19		
VALVE	1 12		
VALVE	1 13		
VALVE	8 14		
VALVE, CHOKE	9 16		
VALVE-EXHAUST	3 2		
VALVE-FLOAT	8 8		
VALVE-FLOAT	9 12		
VALVE-INTAKE	3 1		
VALVE-THROTTLE 110	8 7		
VALVE-THROTTLE, #110	9 11		
W-PLAIN-S	6 22		
W-PLAIN-S	7 38		
WASHER	10 25		
WASHER	6 26		
WASHER	7 37		
WASHER	1 43		
WASHER	7 22		
WASHER	6 13		
WASHER	1 44		
WASHER	5 14		
WASHER	10 26		
WASHER-25X42X1.0	1 27		
WASHER-5X12.8X1.2	12 12		
WASHER-5X16X0.8	1 28		
WASHER-C. 5X11.5X2.0	7 27		
WASHER-C. 5X18X2.0	5 10		
WASHER-C. 5X18X2.0	10 18		

ALPHABETICAL INDEX FC150V-AB03. FB03. GB03

DESCRIPTION	FIG. KEY	DESCRIPTION	FIG. KEY
6 21ANGED	6 18	CAP, AIR FILTER	11 28
ARM	1 14	CAP, GRIP	13 3
ARM-ASSY	8 3	CAP-ASSY-TANK	12 3
ARM-PIVOT	8 4	CAP-SPARK PLUG	6 4
ARM-PIVOT	8 30	CAP-SPARK PLUG	7 4
ARM-ROCKER	3 4	CARBURETOR-ASSY.	9 4
ARM-ROCKER	3 4A	CARBURETOR-ASSY.	10 1
BEARING-BALL	1 47	CASE-ROCKER	1 6
BEARING-BALL	1 24	CHAMBER-FLOAT	9 6
BOLT	8 9	CHAMBER-FLOAT	10 2
BOLT	7 22	CLAMP	6 13
BOLT	7 23	CLAMP	12 12
BOLT	7 24	CLAMP	6 14
BOLT	9 18	CLAMP	12 13
BOLT	10 11	CLAMP	8 12
BOLT	8 21	CLAMP	12 15
BOLT	11 18	CLAMP	12 16
BOLT	3 16	CLAMP	7 20
BOLT	8 31	CLAMP	12 21
BOLT 6X35	14 13	CLAMP	12 20
BOLT, CONNECTING ROD	2 13	CLAMP	7 21
BOLT-FLANGED	1 29	COIL CHARGING	6 10
BOLT-FLANGED	5 12	COIL-ASSY-IGNITION	6 7
BOLT-FLANGED	12 17	COIL-ASSY-IGNITION	7 7
BOLT-FLANGED	1 30	COIL-ASSY-IGNITION	7 8
BOLT-FLANGED	1 44	COIL-CHARGING	7 12
BOLT-FLANGED	12 22	COIL-CHARGING	7 13
BOLT-FLANGED	1 31	COLLAR	9 21
BOLT-FLANGED	8 17	COLLAR	9 22
BOLT-FLANGED	1 32	COLLAR	10 15
BOLT-FLANGED	5 13	COLLAR	10 16
BOLT-FLANGED	6 19	COLLAR	9 27
BOLT-FLANGED	13 22	COLLAR	10 23
BOLT-FLANGED	1 33	COLLAR	8 15
BOLT-FLANGED	1 34	COLLAR, 6x13x2.3	8 14
BOLT-FLANGED	11 27	CONNECTOR-CORD	14 7
BOLT-STUD	11 20	COVER	1 11
BOLT-UPSET-WP	11 21	COVER	5 1
BOLT-UPSET-WSP	1 35	COVER	6 1
BOLT-UPSET-WSP	8 27	COVER	7 1
BRACKET	11 7	COVER	5 2
BRACKET	11 7A	COVER	5 15
CAMSHAFT-COMP	3 9	COVER	5 15A
CAMSHAFT-COMP	3 18	COVER, LOWER	5 3
CAP, AIR FILTER	11 3	COVER, LOWER	5 14

DESCRIPTION	FIG. KEY	DESCRIPTION	FIG. KEY
COVER, UPPER	5 18	GASKET, OIL GAUGE	4 1
COVER, UPPER	5 19	GASKET, ROCKER CASE	1 5
COVER-ASSY STARTER	14 3	GASKET-HEAD	1 1
COVER-CRANKCASE	1 15	GAUGE	4 3
COVER-CRANKCASE	1 38	GEAR-HELICAL	2 14
COVER-MUFFLER	11 10	GEAR-HELICAL	1 19
CRANKCASE-COMP	1 18	GOVERNOR-ASSY	8 20
CRANKCASE-COMP	1 39	GOVERNOR-ASSY	8 40
CRANKCASE-COMP	1 17	GRIP, RECOIL STARTER	13 8
CRANKSHAFT	2 10	GROMMET	5 11
CRANKSHAFT	2 20	GROMMET	5 17
DECOMPRESSOER	3 10	GROMMET	6 17
DECOMPRESSOR	3 10A	GROMMET	7 19
DECOMPRESSOR	3 10B	GUIDE	3 6
ELEMENT-AIR FILTER	11 5	GUIDE	12 1
ELEMENT-AIR FILTER	11 6	GUIDE	4 2
ELEMENT-ASSY-AIR FIL	11 4	GUIDE, ROPE	13 4
ELEMENT-BREATHER	12 5	HEAD-COMP-CYLINDER	1 2
ELEMENT-BREATHER	12 6	HEAD-COMP-CYLINDER	1 48
FILLER	4 4	HOLDER, RECOIL	13 5
FILTER-COMP	12 10	IGNITER	6 3
FILTER-FUEL	12 7	IGNITER	7 3
FILTER-FUEL	12 8	INSULATOR	6 2
FLOAT	9 13	INSULATOR	7 2
FLOAT	10 5	INSULATOR	9 3
FLYWHEEL-ASSY	7 9	INSULATOR	10 28
FLYWHEEL-COMP	6 8	JET-AIR, #0. 9	10 6
GASKET	10 26	JET-MAIN, #68. 8	9 24
GASKET	10 27	JET-MAIN, #68. 8	10 19
GASKET	1 3	JET-PILOT, #38. 8	9 25
GASKET	1 4	JET-PILOT, #45	10 20
GASKET	12 4	KEY	6 15
GASKET	1 49	KEY	7 16
GASKET	1 50	KEY	2 16
GASKET	9 9	LABEL-MANUAL	15 1
GASKET	9 10	LABEL-MANUAL	15 2
GASKET STARTER	14 2	LABEL-MANUAL	15 3
GASKET, CARBURETOR	9 1	LABEL-MANUAL	15 4
GASKET, CARBURETOR	10 29	LEVER	8 6
GASKET, INSULATOR	9 2	LEVER	8 7
GASKET, INSULATOR	10 30	LEVER	12 9
GASKET, INTAKE PIPE	11 1	LINK	8 2
GASKET, INTAKE PIPE	11 1A	LINK	8 34
GASKET, MUFFLER	11 2	LINK-CHOKE	8 1
GASKET, MUFFLER	11 23	LINK-CHOKE	8 38

FC150V-AB03. FB03. GB03

DESCRIPTION	FIG. KEY	DESCRIPTION	FIG. KEY
MOTOR-ELECTRIC	14 4	PLUG	1 28
MUFFLER-COMP	11 9	PLUG	1 45
NOZZLE-MAIN, #2A	9 17	PLUG-SPARK, BP6ES(NGK)	6 16
NOZZLE-MAIN, #2A	10 10	PLUG-SPARK, BP6ES(NGK)	7 17
NUT	8 10	PLUG-SPARK, BP6ES(NGK)	7 18
NUT	5 6	PULLEY-STARTING	13 1
NUT	8 22	REEL, RECOIL STARTER	13 9
NUT	11 13	RETAINER-SPRING	13 7
NUT	13 20	RETAINER-VALVE SP	3 3A
NUT	14 11	RETAINER-VALVE SPRIN	3 3
NUT	8 32	RING-SET-PISTON	2 3
NUT	3 15	RING-SET-PISTON	2 17
NUT, 6MM	3 14	RING-SET-PISTON 0. 25	2 5
NUT, 6MM	5 7	RING-SET-PISTON 0. 25	2 18
NUT-HEX	6 22	RING-SET-PISTON 0. 50	2 6
NUT-HEX	7 27	RING-SET-PISTON 0. 50	2 19
NUT-HEX-FINE	6 23	RING-SET-PISTON 0. 75	2 4
NUT-HEX-FINE	7 28	RING-SNAP	2 15
O RING	1 37	RING-SNAP	10 17
O RING	4 5	RING-SNAP	2 21
PANEL-ASSY-CONTROL	8 5	ROD-ASSY U/S=0. 50	2 12
PANEL-ASSY-CONTROL	8 39	ROD-ASSY-CONNECTING	2 11
PANEL-CONTROL	8 8	ROD-PUSH	3 7
PANEL-CONTROL	8 41	ROPE, 3. 8x1600	13 10
PAWL, RECOIL STARTER	13 6	SCREW	6 11
PIN	9 23	SCREW	9 7
PIN	1 23	SCREW	9 19
PIN	10 18	SCREW	7 25
PIN	3 11	SCREW	10 12
PIN	3 17	SCREW	10 13
PIN	3 12	SCREW	11 11
PIN-DOWEL	1 36	SCREW	9 20
PIN-DOWEL	13 23	SCREW	10 14
PIN-DOWEL	14 14	SCREW	12 11
PIN-PISTON	2 2	SCREW	7 14
PIN-SNAP	8 29	SCREW	11 24
PIPE-INTAKE	11 8	SCREW 5X32	14 8
PISTON-ENGINE	2 1	SCREW, 5x18	13 11
PISTON-ENGINE 0. 75	2 7	SCREW, 5x8	1 20
PISTON-ENGINE L, 0. 25	2 8	SCREW, 5x8	11 12
PISTON-ENGINE L, 0. 50	2 9	SCREW-PAN	11 19
PLATE	1 9	SCREW-PAN+-	9 29
PLATE	1 10	SCREW-PAN+-	10 25
PLATE	1 51	SCREW-PAN+-	8 18
PLATE	1 52	SCREW-PAN-WP	6 20

DESCRIPTION	FIG. KEY	DESCRIPTION	FIG. KEY
SCREW-PAN-WP+-	12 18	STUD	5 5
SCREW-PAN-WP+-	6 21	TANK-COMP-FUEL	12 2
SCREW-PAN-WP+-	7 26	TAPPET	3 5
SCREW-PAN-WS-CROS	14 9	TERMINAL	6 6
SCREW-PAN-WS-CROS	14 10	TERMINAL	7 5
SCREW-PILOT AIR	9 5	TERMINAL	7 6
SEAL	12 24	TERMINAL	6 5
SEAL	10 22	TOOL KIT	16 1
SEAL-OIL	1 25	TOOL KIT	16 4
SEAL-OIL	1 26	TOOL-DRIVER	16 2
SEAL-OIL	1 42	TOOL-DRIVER	16 5
SEAL-OIL	1 43	TOOL-WRENCH, 19x21	16 3
SHAFT	1 7	TOOL-WRENCH, 19x21	16 6
SHAFT	1 8	TUBE	1 27
SHAFT-CARBURETOR, CH	9 15	TUBE	11 17
SHAFT-CARBURETOR, CH	10 8	TUBE	13 21
SHAFT-CARBURETOR, TH	9 14	TUBE	14 12
SHAFT-CARBURETOR, TH	10 7	TUBE	12 14
SLEEVE	8 19	TUBE, 4x7x125	10 24
SLEEVE	8 35	TUBE, 5x8x125	9 28
SLINGER-OIL	1 16	TUBE-4. 8X10. 3X415	12 23
SPACER, 6. 2x7. 8x17	5 9	TUBE-BRAID L=405MM	12 19
SPACER, 6. 2x7. 8x22	5 10	VALVE	1 12
SPACER, 6. 2x7. 8x8	11 16	VALVE	1 13
SPRING	9 8	VALVE	1 53
SPRING	9 26	VALVE	1 54
SPRING	8 13	VALVE, CHOKE	9 16
SPRING	10 21	VALVE, CHOKE	10 9
SPRING	3 13	VALVE-EXHAUST	3 2
SPRING	13 14	VALVE-FLOAT	9 12
SPRING	8 16	VALVE-FLOAT	10 4
SPRING	8 25	VALVE-INTAKE	3 1
SPRING	8 26	VALVE-THROTTLE, #110	9 11
SPRING	8 33	VALVE-THROTTLE, #110	10 3
SPRING, LINK	8 24	W-PLAIN-S	6 24
SPRING, RECOIL	13 13	W-PLAIN-S	7 29
SPRING, RECOIL	13 16	W-PLAIN-S	8 28
SPRING, RETURN	13 15	W-PLAIN-S	8 37
SPRING-ENGINE VALVE	3 8	WASHER	11 14
SRARTER-ELECTRIC	14 1	WASHER	6 12
STARTER-ELECTRIC	13 17	WASHER	8 23
STARTER-ELECTRIC	13 18	WASHER	1 21
STARTER-RECOIL	13 2	WASHER	8 36
STUD	5 4	WASHER	7 15
STUD	5 14	WASHER	1 22

ALPHABETICAL INDEX

FC150V-EB05

DESCRIPTION	FIG. KEY	DESCRIPTION	FIG. KEY
ARM	1 14	CLAMP	10 15
ARM-ASSY	7 3	CLAMP	10 16
ARM-PIVOT	7 4	CLAMP	6 16
ARM-ROCKER	3 4	COIL-ASSY-IGNITION	6 9
BAND-BRAKE	12 2	COLLAR	8 21
BEARING-BALL	1 36	COLLAR	8 22
BOLT	8 18	COLLAR	8 29
BOLT	7 21	COLLAR	7 13
BOLT	9 16	COLLAR, 6x13x2. 3	7 12
BOLT	3 15	COVER	1 11
BOLT, 5x18	7 16	COVER	6 2
BOLT, CONNECTING ROD	2 11	COVER	6 3
BOLT-FLANGED	1 29	COVER	5 3
BOLT-FLANGED	5 12	COVER, LOWER	5 2
BOLT-FLANGED	12 8	COVER, UPPER	5 1
BOLT-FLANGED	1 30	COVER-CRANKCASE	1 15
BOLT-FLANGED	10 18	COVER-MUFFLER	9 10
BOLT-FLANGED	7 17	CRANKCASE-COMP	1 17
BOLT-FLANGED	1 31	CRANKSHAFT	2 8
BOLT-FLANGED	5 13	DECOMPRESSOER	3 10
BOLT-FLANGED	6 19	ELEMENT-AIR FILTER	9 3
BOLT-FLANGED	1 32	ELEMENT-AIR FILTER	9 4
BOLT-FLANGED	1 33	ELEMENT-ASSY-AIR FIL	9 2
BOLT-STUD	9 19	ELEMENT-BREATHER	10 10
BOLT-UPSET	6 17	FILLER	4 4
BOLT-UPSET-WP	9 20	FILTER-COMP	10 5
BOLT-UPSET-WSP	1 34	FILTER-FUEL	10 2
BOLT-UPSET-WSP	7 28	FILTER-FUEL	10 3
BOLT-UPSETED	6 18	FLOAT	8 12
BOLT/5X18	12 7	FLYWHEEL-COMP	6 10
BRACKET	12 1	GASKET	8 5
BRACKET	9 5	GASKET	8 6
CAMSHAFT-COMP	3 9	GASKET	10 9
CAP, AIR FILTER	9 1	GASKET, CARBURETOR	8 1
CAP, GRIP	11 3	GASKET, COVER	1 5
CAP-ASSY-TANK	10 8	GASKET, CRANKCASE COV	1 6
CAP-SPARK PLUG	6 7	GASKET, INSULATOR	8 2
CARBURETOR-ASSY.	8 4	GASKET, INTAKE PIPE	9 7
CASE-ROCKER	1 4	GASKET, MUFFLER	9 6
CHAMBER-FLOAT	8 7	GASKET, OIL GAUGE	4 1
CIRCLIP-TYPE-E	12 10	GASKET, ROCKER CASE	1 3
CLAMP	10 11	GASKET-HEAD	1 1
CLAMP	7 11	GAUGE	4 3
CLAMP	12 4	GEAR-HELICAL	2 12
CLAMP	10 14	GEARHELICAL	1 18

FC150V-EB05

DESCRIPTION	FIG. KEY	DESCRIPTION	FIG. KEY
GOVERNOR-ASSY	7 20	PIN	12 5
GRIP, RECOIL STARTER	11 8	PIN COTTER	12 11
GROMMET	5 10	PIN-DOWEL	1 35
GUIDE	3 6	PIN-PISTON	2 4
GUIDE	10 1	PIN-SNAP	7 29
GUIDE	4 2	PIPE-INTAKE	9 8
GUIDE, ROPE	11 4	PISTON-ENGINE	2 1
HEAD-COMP-CYLINDER	1 2	PISTON-ENGINE L, 0. 25	2 2
HOLDER, RECOIL	11 5	PISTON-ENGINE L, 0. 50	2 3
IGNITER	6 6	PLATE	6 1
INSULATOR	6 4	PLATE	1 9
INSULATOR	6 5	PLATE	1 10
INSULATOR	8 3	PLUG	1 24
JET-AIR, #0. 9	8 13	PLUG	1 25
JET-MAIN, #68. 8	8 25	PLUG-SPARK, BP5ES(NGK)	6 15
JET-PILOT, #45	8 26	PULLEY-STARTING	11 1
KEY	6 14	REEL, RECOIL STARTER	11 9
KEY	2 14	RETAINER-SPRING	11 7
LABEL-MANUAL	13 1	RETAINER-VALVE SPRIN	3 3
LABEL-MANUAL	13 2	RING-SET-PISTON	2 5
LEVER	7 6	RING-SET-PISTON 0. 25	2 6
LEVER	7 7	RING-SET-PISTON 0. 50	2 7
LEVER	10 4	RING-SNAP	8 23
LEVER-BRAKE	12 3	RING-SNAP	2 13
LINK	7 2	ROD-ASSY-CONNECTING	2 9
LINK-CHOKE	7 1	ROD-ASSY-CONNECTING,	2 10
MUFFLER-COMP	9 9	ROD-PUSH	3 7
NOZZLE-MAIN	8 17	ROPE, 3. 8x2000	11 10
NUT	5 6	SCREW	8 8
NUT	7 22	SCREW	8 19
NUT	9 13	SCREW	8 20
NUT	7 9	SCREW	10 6
NUT	3 14	SCREW	9 12
NUT, 6MM	3 13	SCREW, 5x18	11 11
NUT, 6MM	5 7	SCREW, 5x8	1 19
NUT-HEX	6 21	SCREW, 5x8	9 11
NUT-HEX-FINE	6 22	SCREW-PAN+-	8 31
O RING	1 37	SCREW-PAN+-	7 18
O RING	4 5	SCREW-PAN+-	9 21
PANEL-ASSY-CONTROL	7 5	SCREW-PAN-WP+-	10 19
PANEL-CONTROL	7 8	SCREW-PAN-WP+-	6 20
PAWL, RECOIL STARTER	11 6	SEAL	10 13
PIN	1 20	SEAL	8 28
PIN	8 24	SEAL-OIL	1 21
PIN	3 11	SEAL-OIL	1 22

DESCRIPTION	FIG. KEY	DESCRIPTION	FIG. KEY
SHAFT	1 7	WASHER	7 23
SHAFT	1 8	WASHER	6 13
SHAFT-CARBURETOR, CH	8 15	WASHER, 5x12. 8x1. 2	11 12
SHAFT-CARBURETOR, TH	8 14	WASHER, 5x16x0. 8	1 27
SLEEVE	7 19	WASHER, 6. 5x11. 5x2. 0	7 27
SLINGER-OIL	1 16	WASHER, 6. 5x18x2. 0	5 11
SPACER, 6. 2x7. 8x17	5 8	WASHER, 6. 5x18x2. 0	9 18
SPACER, 6. 2x7. 8x22	5 9	WASHER, 6x12x1. 6	1 28
SPACER, 6. 2x7. 8x8	9 14	WASHER, 6x19x1. 2	7 10
SPRING	8 9	WASHER, 7x21x2. 3	9 17
SPRING	8 27	WASHER-PLAIN	9 22
SPRING	3 12	WASHER/25X42X1. 0	1 26
SPRING	11 14	WIRE-LEAD	6 11
SPRING	7 14	WIRE-LEAD	6 12
SPRING	7 25		
SPRING	7 26		
SPRING	7 15		
SPRING	12 6		
SPRING, LINK	7 24		
SPRING, RECOIL	11 13		
SPRING, RETURN	11 15		
SPRING-ENGINE VALVE	3 8		
STARTER-RECOIL	11 2		
STUD	5 4		
STUD	5 5		
TANK-COMP-FUEL	10 7		
TAPPET	3 5		
TERMINAL	6 8		
TOOL KIT	14 1		
TOOL-DRIVER	14 2		
TOOL-WRENCH, 19x21	14 3		
TUBE	1 23		
TUBE	9 15		
TUBE	10 12		
TUBE, 4. 3x10. 3x415	10 17		
TUBE, 4X7X125	8 30		
VALVE	8 16		
VALVE	1 12		
VALVE	1 13		
VALVE-EXHAUST	3 2		
VALVE-FLOAT	8 11		
VALVE-INTAKE	3 1		
VALVE-THROTTLE, #110	8 10		
W-PLAIN-S	6 23		
W-PLAIN-S	12 9		

ALPHABETICAL INDEX

CHASSIS

DESCRIPTION	FIG. KEY	DESCRIPTION	FIG. KEY
ARM/CLUTCH	6 4	BOLT/TAPPING/6X16	2 14
B. B. C. ASSY	2 1	BOLT/TAPPING/6X16	5 11
B. B. C. /5. 5PS ASSY	2 1A	BOLT/TAPPING/6X16	5 15
BAND/BATTERY	17 9	BOLT/TAPPING/6X16	8 6
BAND/WIRE/140	24 5	BOLT/TAPPING/6X16	8 23
BAND/WIRE/140	24 8	BOLT/TAPPING/6X16	11 9A
BAND/WIRE/140	27 14	BOLT/TAPPING/6X16	13 5
BAND/WIRE/140	28 16	BOLT/UNF3/8X31	2 10
BAR/WRENCH	30 2	BOLT/UNF3/8X38	3 3
BATTERY SET	27 12	BOOT	4 6
BATTERY/5 SET	27 12A	BOSS	3 1
BATTERY/J SET	28 14	BRACKET, F WHEEL/LH	9 1
BEARING, RB/6201	8 14A	BRACKET/BATTERY COMP	17 1
BEARING, RB/6201	9 11	BRACKET/F WHEEL/LH	9 1A
BLADE/525	3 5	BRACKET/F WHEEL/RH	9 2
BOLT	2 2	BRACKET/F WHEEL/RH	9 2A
BOLT	6 5	BRACKET/HANDLE COMP	15 1
BOLT	23 23	BRACKET/HANDLE COMP	16 2
BOLT	30 4	BRACKET/HANDLE COMP	18 1
BOLT, SP/M6X12	27 10	BRACKET/HANDLE COMP	19 1
BOLT, SP/M6X12	28 11	BRACKET/WHEEL/LH	8 1
BOLT, SP/M6X16	8 11A	BRACKET/WHEEL/LH	8 1A
BOLT, TAPPING/06X35	5 12	BRACKET/WHEEL/RH	8 3
BOLT/FLANGE/M06X25	8 11	BRACKET/WHEEL/RH	8 3A
BOLT/FLANGE/M10X30	1 2A	BUSH/10X12X20	5 3
BOLT/FLANGE/M10X30	1 2B	BUSH/12X14X20	7 7
BOLT/FLANGE/M10X30	1 7	BUSH/12X14X20	8 2
BOLT/FLANGE/M8X35	17 4	BUSH/12X14X20	8 4
BOLT/M08X40	15 2	BUSH/12X15X20	8 2A
BOLT/M08X45	9 5A	BUSH/12X15X20	8 4A
BOLT/M10X1.25X20	3 7	BUSH/14X16X10	14 2
BOLT/M10X55	30 5	BUSH/14X20X11	21 11
BOLT/M8X30	9 5	BUSH/14X20X11	23 5
BOLT/M8X40	16 4	BUSH/14X20X11	25 8
BOLT/M8X40	18 2	CABLE/BBC	2 12
BOLT/M8X40	19 2	CABLE/BRAKE	24 6
BOLT/P	14 4	CABLE/CHANGE	24 2
BOLT/SP	14 4A	CABLE/CLUTCH	24 3
BOLT/SP 7	1 2	CABLE/THROTTLE	24 1
BOLT/TAPPING/06X25	5 10	CAM, SHIFT	6 19
BOLT/TAPPING/6X12	11 3	CAM/DRIVE CLUTCH	6 10
BOLT/TAPPING/6X12	11 6	CAM/RACHET	7 4
BOLT/TAPPING/6X12	11 9	CAP	27 3
BOLT/TAPPING/6X12	12 2	CAP	28 6
BOLT/TAPPING/6X12	12 4	CAP	27 19

DESCRIPTION	FIG. KEY	DESCRIPTION	FIG. KEY
CAP	8 8	FORK COMP	6 3
CAP/WHEEL	8 21	FRAME, COLLECTOR COMP	26 1
CAP/WHEEL	8 36	FUSE/BLADE/32V01A	27 16
CAP/WHEEL	9 16	FUSE/BLADE/32V01A	28 3
CASE, MISSION ASSY	5 2A	GASKET	5 6
CASE, MISSION/LH	5 1	GEAR, SPUR/13 ASSY	7 6
CASE, MISSION/LH	5 1A	GEAR, SPUR/42	8 16
CASE, MISSION/RH ASSY	5 2	GEAR, SPUR/42	8 31
CIRCLIP	4 4	GEAR/BEVEL/14	6 1
CLAMP, HARNESS	16 5	GEAR/BEVEL/14	6 1A
CLAMP, HARNESS	18 3	GEAR/BEVEL/55	6 11
CLAMP, HARNESS	19 3	GEAR/BEVEL/55	6 11A
CLAMP, HARNESS	24 4	GEAR/OUTPUT	6 22
CLAMP/?	12 3	GEAR/SPAR/26	6 17
CLAMP/FLASHER HARNES	1 3	GEAR/SPAR/30	6 16
CLIP	23 19	GRIP	8 26
CLOTH, COLLECTOR COMP	26 4	GRIP	9 4
COLLAR/15X20X8	23 12	HANDEL, B COMP	14 1
COLLAR/15X20X8	25 3	HANDLE, A	16 1
COLLAR/6X10X32	14 11	HANDLE, B COMP	14 1A
CONTAINER ASSY	27 13	HANDLE, B COMP	14 1B
CONTAINER/5 ASSY	27 13A	HANDLE/A	16 9
CONTAINER/J ASSY	28 15	HANDLE/A COMP	18 7
COVER, COLLECTOR	26 2	HANDLE/A/G	17 3
COVER, DECK/LH	11 4	HANDLE/A/G	19 7
COVER, DECK/RH	11 5	HANDLE/B/E COMP	20 1
COVER, DESCHARGE	13 1	HANDLE/B/E COMP	20 1A
COVER, FAN/N	12 1	HARNES/BATTERY ASSY	27 9
COVER, HOLDER	14 12	HARNES/BATTERY ASSY	28 13
COVER, MISSION	11 7	HARNES/MAIN ASSY	27 1
COVER, MISSION	11 7A	HARNES/MAIN ASSY	28 1
COVER, MISSION	11 7B	HARNES/MAIN ASSY	27 15
COVER, STONE GUARD	11 10	HARNES/MAIN ASSY	28 1A
COVER, UNDER	11 2	HOLDER	5 14
COVER, WHEEL	8 9	HOLDER, BRACKET, WHEEL	8 5
COVER, WHEEL	8 9A	HOLDER, BRACKET, WHEEL	8 22
COVER/1P FUSE BOX	27 17	HOLDER, RACHET	7 3
COVER/1P FUSE BOX	28 4	HOLRER, ADJ, HIGH COMP	8 24
COVER/CONTROL	21 8	HGSE	26 3
COVER/CONTROL	22 8	INSULATOR	17 2
COVER/CONTROL	23 15	JOINT ASSY	4 1
COVER/ENGINE/SHAFT	1 1	JOINT ASSY	10 1
COVER/ENGINE/SHAFT	1 6	JOINT/A	10 2
DECK	11 1	JOINT/B	10 4
DECK	11 1A	KEY ASSY	27 21

CHASSIS

DESCRIPTION	FIG. KEY	DESCRIPTION	FIG. KEY
KEY ASSY	28 10A	LEVER/LOCK COMP	25 11A
KEY/04X06X16	2 11	LEVER/PIPE/E COMP	23 2
KEY/04X06X16	3 4	LEVER/SPRING/FRONT	9 3
LABEL	29 13	MANUAL/OPRATION/4	30 11
LABEL	29 19	MANUAL/OPRATION/4	30 11A
LABEL, CONTROL	29 5	MANUAL/OPRATION/J	30 10
LABEL, CONTROL	29 5A	NUT	6 6
LABEL, ENGINE/LH/A	29 2	NUT	27 11
LABEL, ENGINE/RH	29 3	NUT	27 22
LABEL, ENGINE/TOP	29 1	NUT	28 12
LABEL, NOISE/100	29 6	NUT	14 5
LABEL, TRAVEL	29 7	NUT	14 13
LABEL/BBC	29 9	NUT	23 25
LABEL/BBC	29 9A	NUT, CAP/M8	15 4
LABEL/BBC	29 9B	NUT, CAP/M8	16 8
LABEL/CAUTION	29 11	NUT, CAP/M8	18 6
LABEL/CAUTION	29 11A	NUT, CAP/M8	19 6
LABEL/CAUTION/J	29 18	NUT, CAP/M8	23 16
LABEL/CE	29 14	NUT, CAP/M8	25 6
LABEL/DANGER	29 10	NUT, RING/M22X1.0	27 4
LABEL/DANGER	29 10A	NUT, RING/M22X1.0	28 7
LABEL/DANGER/J	29 17	NUT, RING/M22X1.0	27 20
LABEL/MODEL ASSY	29 8	NUT/FLANGE/M06	8 10
LABEL/PLUG	29 12	NUT/FLANGE/M06	8 12
LABEL/SELF	29 15	NUT/FLANGE/M06	8 27
LABEL/START	29 16	NUT/FLANGE/M06	21 7
LABEL/START	29 16A	NUT/FLANGE/M06	22 7
LABEL/START	29 16B	NUT/FLANGE/M06	23 11
LABEL/TRAVEL	29 7A	NUT/KNOB/M8	14 7
LEVER COMP	23 2A	NUT/KNOB/M8	14 9
LEVER COMP	25 1	NUT/KNOB/M8	16 11
LEVER, PIPE COMP	21 10	NUT/KNOB/M8	17 8
LEVER, SPRING, FRONT	9 3A	NUT/KNOB/M8	18 9
LEVER, SPRING/REAR	8 25	NUT/KNOB/M8	19 9
LEVER/AXLE	21 1	NUT/KNOB/M8	20 3
LEVER/AXLE	22 1	NUT/M08	9 8A
LEVER/AXLE	23 1	NUT/M10	1 5
LEVER/BBC	21 13	NUT/M10	30 8
LEVER/BBC	25 9	NUT/M8	8 20
LEVER/BBC	23 8	NUT/M8	8 34
LEVER/BBC	25 9A	NUT/M8	9 9
LEVER/CHANGE COMP	21 4	NUT/M8	9 14
LEVER/CHANGE COMP	22 4	NUT/M8	15 3
LEVER/CHANGE COMP	23 6	NUT/M8	17 5
LEVER/LOCK COMP	25 11	NUT/U/M8	9 8

DESCRIPTION	FIG. KEY	DESCRIPTION	FIG. KEY
PANEL/SELF	17 10	SCREW/M4X6	28 8
PANEL/SELF	17 10A	SCREW/TAPPING/5X16	17 11
PIN	4 5	SCREW/TAPPING/5X16	21 9
PIN	21 15	SCREW/TAPPING/5X16	22 9
PIN, /05X22	6 23	SCREW/TAPPING/5X16	23 17
PIN, CROSS	4 3	SEAL, OIL	5 4
PIN, STRAIGHT/04X18/A	7 2	SEAL, OIL	5 8
PIN/08X334	13 3	SEAL, OIL	5 7
PIN/08X45	14 6	SEAL12X05	7 1
PIN/08X45	14 8	SHAFT, INPUT	6 8
PIN/08X45	20 2	SHAFT, INPUT	6 8A
PIN/14X70	23 10	SHAFT, SPLINE	10 3
PIN/14X70	25 2	SHAFT, WHEEL	6 21
PIN/4X18	10 5	SHIFTER COMP	5 13
PIN/8X14	2 16	SHIM/O. 3X20X30	6 13A
PIN/8X14	23 21	SHIM/O. 5	6 13
PIN/8X49	6 20	SPECIAL TOOL COMP	30 3
PIPE	4 2	SPECIAL TOOL/ENGINE	30 9
PLATE	2 7	SPRING	2 15
PLATE	5 9	SPRING/DISK/10	21 2
PLATE, 1/16X28	13 4	SPRING/DISK/10	22 2
PLATE/520	3 5A	SPRING/DISK/10	23 3
PLATE/SPRING	14 10	SPRING/HCO12	13 2
PLATE/SPRING	23 22	SPRING/HCO16	2 3
PLATE/WIRE	2 13	SPRING/HCO39	6 7
PLUG, 19	16 3	SPRING/HCO48	6 18
PLUG/19	17 7	SPRING/HE077	21 5A
R. B. B.	8 14	SPRING/HE077	21 12A
R. B. B.	8 29	SPRING/HE077	22 5
RELAY/4P ASSY	27 2	SPRING/HE077	23 7A
RELAY/4P ASSY	28 2	SPRING/HE077	25 10
RIM, REAR ASSY	8 13	SPRING/HE079	23 7
RIM, REAR ASSY	8 28	SPRING/HE108	2 6
RIM, REAR ASSY	8 13A	SPRING/HE145	23 20
RING, SNAP/14C	23 18	SPRING/HT010	25 12
RING, SNAP/14C	25 7	SPRING/HT010	25 12A
RING, SNAP/20C	7 9	SPRING/HT07	24 7
RING, SNAP/20C	6 14	SPRING/RACHET	7 5
RING, SNAP/20C	10 6	SWITCH/KEY ASSY	27 7
RING, SNAP/7E	25 13A	SWITCH/KEY ASSY	28 10
RING, SNAP/7E	25 13	SWITCH/STARTER ASSY	28 5
RING, SNAP/9 E	4 7	SWITCH/STARTER/5P	28 5A
SCREW, TAPPING/6X25	8 17	SWITCH/STARTER/5PSET	27 18
SCREW, TAPPING/6X25	8 32	SWITCH/STATER	27 6
SCREW/M4X6	27 8	TYRE/8X2	9 12

CHASSIS

DESCRIPTION	FIG. KEY	DESCRIPTION	FIG. KEY
TYRE/9X2	8 15	WASHER/11X20X01	21 3
TYRE/9X2	8 30	WASHER/11X20X01	22 3
WASHER	3 6	WASHER/11X20X01	23 4
WASHER	6 12	WASHER/11X22X3	2 8
WASHER	6 15	WASHER/11X45X03	2 4
WASHER	2 9	WASHER/12X21X01	6 24
WASHER	11 8	WASHER/12X21X01	7 8
WASHER	21 6A	WASHER/12X21X01	8 7
WASHER	22 6	WASHER/15X24X2	21 14
WASHER	23 9	WASHER/15X24X2	23 13
WASHER	4 8	WASHER/15X24X2	25 4
WASHER, PL	23 24	WASHER/17X24X01	6 9
WASHER, PL	2 5	WASHER/6X14X2	14 3
WASHER, PL	8 18	WHEEL/FRONT ASSY	9 10
WASHER, PL	8 33	WRENCH/PLUG	30 1
WASHER, PL	9 7	ナット(SW521)	29 4
WASHER, PL	9 13		
WASHER, PL	15 6		
WASHER, PL	16 6		
WASHER, PL	16 10		
WASHER, PL	18 4		
WASHER, PL	18 8		
WASHER, PL	19 4		
WASHER, PL	19 8		
WASHER, RL	9 6		
WASHER, SP/M10	1 4		
WASHER, SP/M10	3 8		
WASHER, SP/M4	27 5		
WASHER, SP/M4	28 9		
WASHER, SP/M8	8 19		
WASHER, SP/M8	8 35		
WASHER, SP/M8	9 15		
WASHER, SP/M8	15 5		
WASHER, SP/M8	16 7		
WASHER, SP/M8	17 6		
WASHER, SP/M8	18 5		
WASHER, SP/M8	19 5		
WASHER, SP/M8	23 14		
WASHER, SP/M8	25 5		
WASHER/10X37XC6	30 7		
WASHER/10X55X5	3 2		
WASHER/10X55X5	30 6		
WASHER/11X20X01	5 5		
WASHER/11X20X01	6 2		
WASHER/11X20X01	10 7		