

4 & 2  
wheel drive

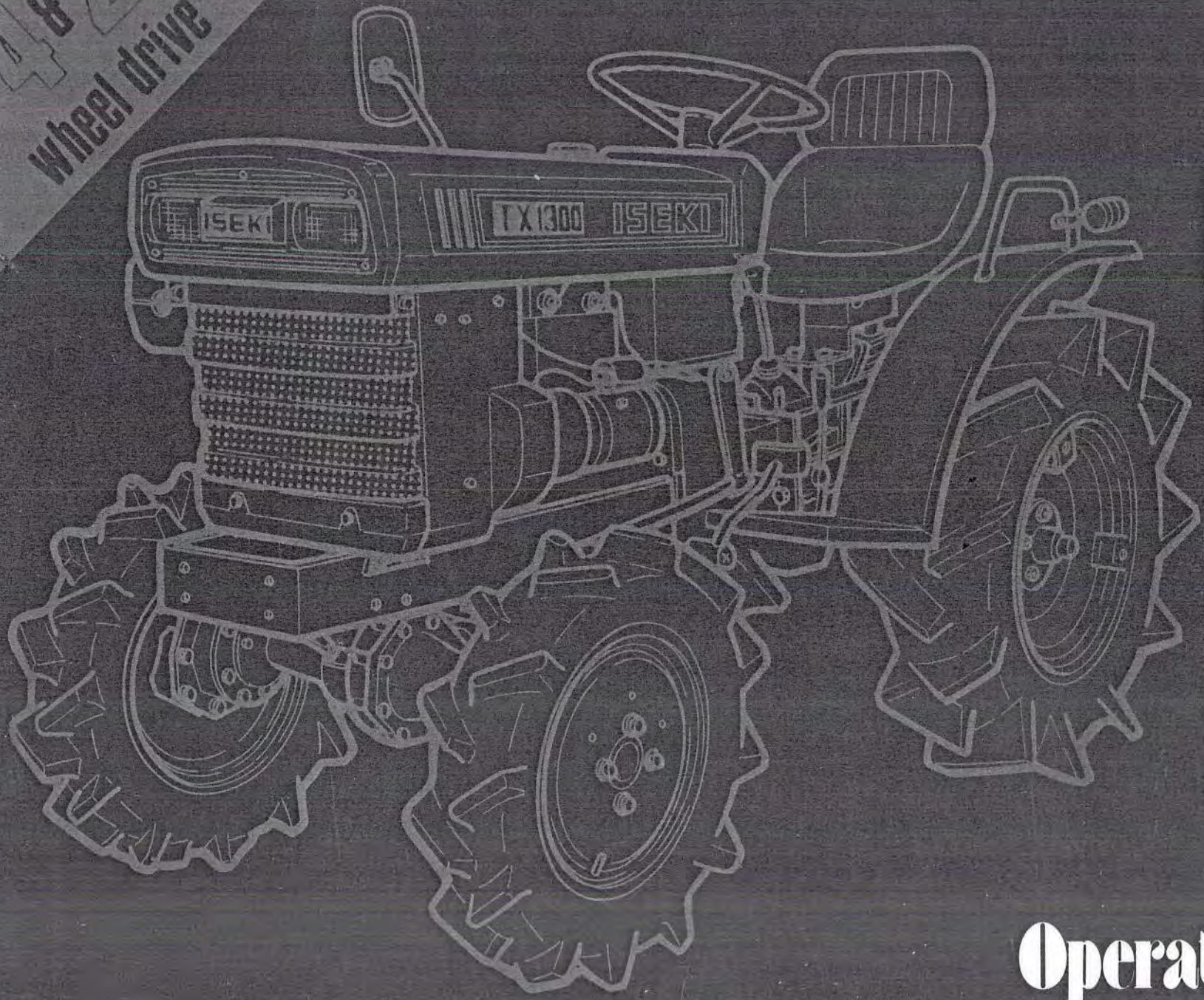

# ISEKI TRACTOR TX series

Operation Manual



## FOREWORD

Your new ISEKI tractor has been designed by the ISEKI & CO., LTD., a manufacturer with long experience in the development and production of agricultural machinery and equipment. ISEKI is proud of its engineering skills and manufacturing processes, which place particular emphasis upon strict quality control, product durability, and safety of operation.

We are confident that your new ISEKI tractor will provide you with many years of outstanding performance. It is a modern machine, equipped with the latest devices, and designed for maximum operator safety and convenience. This Manual is intended to provide basic information and instructions concerning the new ISEKI tractor and its operation. By following the guide lines described in this Manual, you are assured of achieving top performance from your new ISEKI tractor.

Read this Manual carefully, and understand it thoroughly before you attempt to use the tractor or implements, to assure safe and productive operation and maintenance.

## CONTENTS

1. OUTER VIEW AND NAME OF PART .....	1	7. MAINTENANCE, INSPECTION AND ADJUSTMENT ...	19
2. OPERATION OF THE NEW MACHINE .....	3	1. MACHINE PRELIMINARY CHECKS .....	19
3. CONTROLS AND INDICATORS .....	4	2. LUBRICATION .....	21
1. WARNING LAMPS AND SWITCHES .....	4	3. LUBRICATION CHART (AND COOLANT) .....	23
2. CONTROL LEVERS AND PEDALS .....	7	4. PERIODICAL SERVICE TABLE .....	26
3. OPERATION OF HYDRAULIC SYSTEM .....	10	5. INSPECTION AND ADJUSTMENT .....	29
4. OPERATING THE TRACTOR .....	12	● CLUTCH PEDAL .....	29
1. STARTING THE ENGINE .....	12	● BRAKE PEDAL .....	29
2. STOPPING THE ENGINE .....	13	● THROTTLE LEVER .....	30
3. BASIC OPERATION OF THE TRACTOR .....	14	● TOE-IN ADJUSTMENT .....	30
4. OPERATION CHECK DURING WORK .....	15	● FREE PLAY OF STEERING WHEEL .....	30
5. STORAGE .....	16	● AIR BLEEDING FROM THE FUEL SYSTEM ....	31
1. DAILY STORAGE .....	16	● ADJUSTING FRONT AND REAR TREADS .....	31
2. LONG-TIME STORAGE .....	16	● ADJUSTING OPERATOR'S SEAT .....	34
3. OPERATION AFTER LONG-TERM STORAGE ....	17	● BATTERY INSPECTION .....	34
6. OPERATION IN COLD WEATHER .....	18	● INSPECTING AND SERVICING THE AIR CLEANER .....	35
1. ENGINE OIL .....	18	● RADIATOR .....	35
2. ANTI-FREEZE SOLUTION .....	18	8. PROBLEM SOLVING .....	36
3. BATTERY MAINTENANCE .....	18	9. SAFETY PRECAUTIONS .....	40
4. OPERATION IN SNOW OR FROZEN ROADS..	18	10. ADDITIONAL INFORMATION .....	45
		1. RECOMMENDED LUBRICANTS CHART .....	45
		2. IMPLEMENTS LIST .....	46
		3. SPECIFICATIONS .....	49
		4. ELECTRICAL WIRING DIAGRAM .....	51

1

OUTER VIEW AND NAME OF PART



# 1) 4-Wheel Drive Tractor

1. Engine hood
2. Light grill
3. Head light
4. Grill
5. Front hitch
6. Front wheel
7. Clutch pedal
8. Step
9. Rear wheel
10. PTO speed change lever
11. Lift arm
12. Main speed change lever
13. Instrument panel
14. Turn signal light
15. Arm-rest
16. Fender
17. Aux. speed change lever
18. Front wheel drive lever
19. Brake pedal
20. Axle housing
21. Bevel case
22. Front gear case
23. Muffler
24. Fuel tank cap
25. Rear-view mirror
26. Steering wheel
27. Throttle lever
28. Operator's seat
29. Hydraulic control lever
30. Foot accelerator

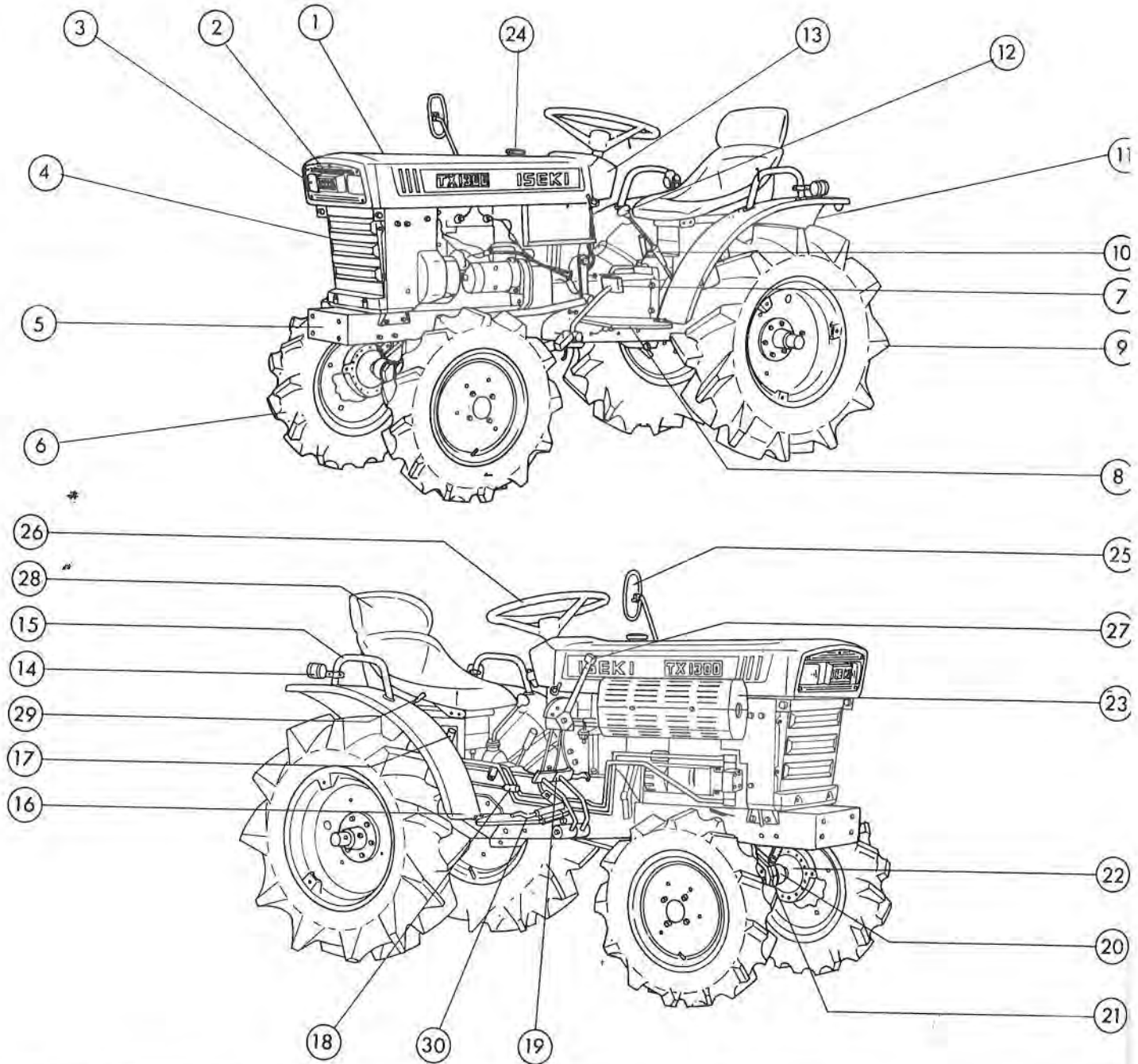

## 2) 2-Wheel Drive Tractor

1. Engine hood
2. Light grill
3. Head light
4. Grill
5. Front hitch
6. Front wheel
7. Clutch pedal
8. Step
9. Rear wheel
10. PTO speed change lever
11. Lift arm
12. Main speed change lever
13. Instrument panel
14. Turn signal light
15. Arm-rest
16. Fender
17. Aux. speed change lever
18. Brake pedal
19. Front axle
20. Muffler
21. Fuel tank cap
22. Rear-view mirror
23. Steering wheel
24. Throttle lever
25. Operator's seat
26. Hydraulic control lever
27. Foot accelerator

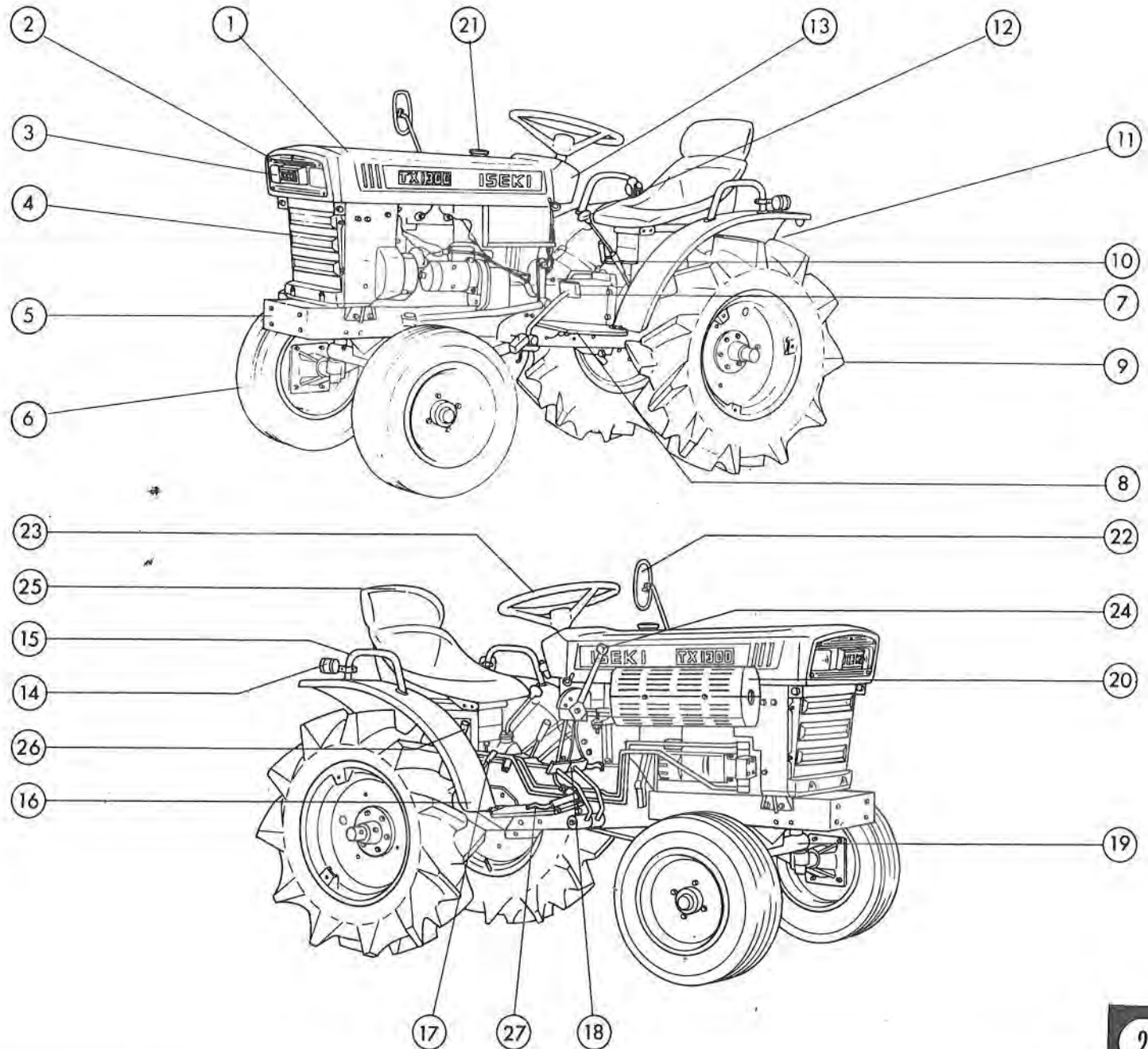

2

OPERATION OF THE NEW MACHINE



ISEKI continues to modernize and improve its products. Accordingly, it is possible that some of the specifications and instructions in this Manual may differ from those applicable to our latest models. When in doubt, refer to your nearest dealer.

Your new machine should be operated carefully to prolong its service life, and assure top performance. During the initial 50 hours of operation, the following cautions should be adhered to:

### 1. CAUTIONS CONCERNING OPERATION OF THE NEW MACHINE

- Read and thoroughly understand the caution plates attached to the appropriate parts of the machine.
- Warm up the engine at low speed, before starting daily activities.
- Avoid sudden starts, full acceleration and sudden braking.
- Change lubrication oil frequently. Always keep oil at the full level.

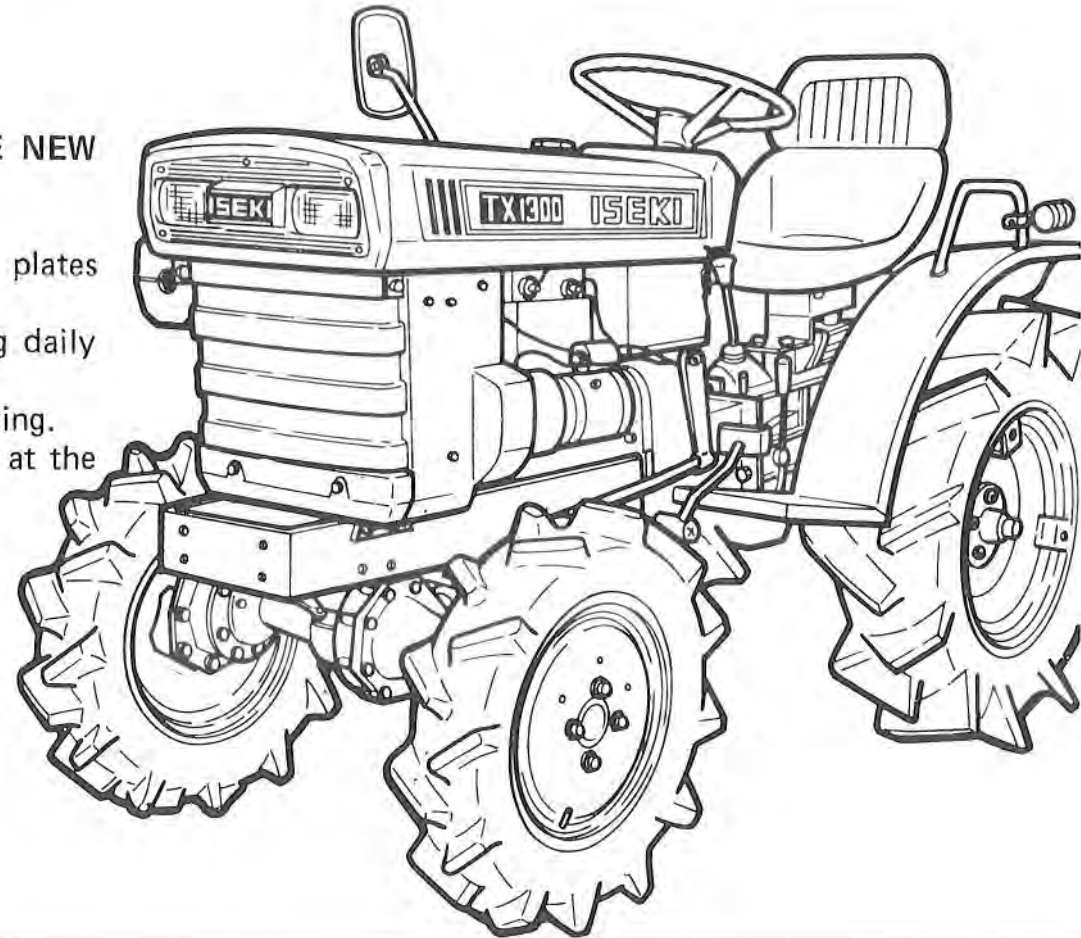



# 3

## CONTROLS AND INDICATORS



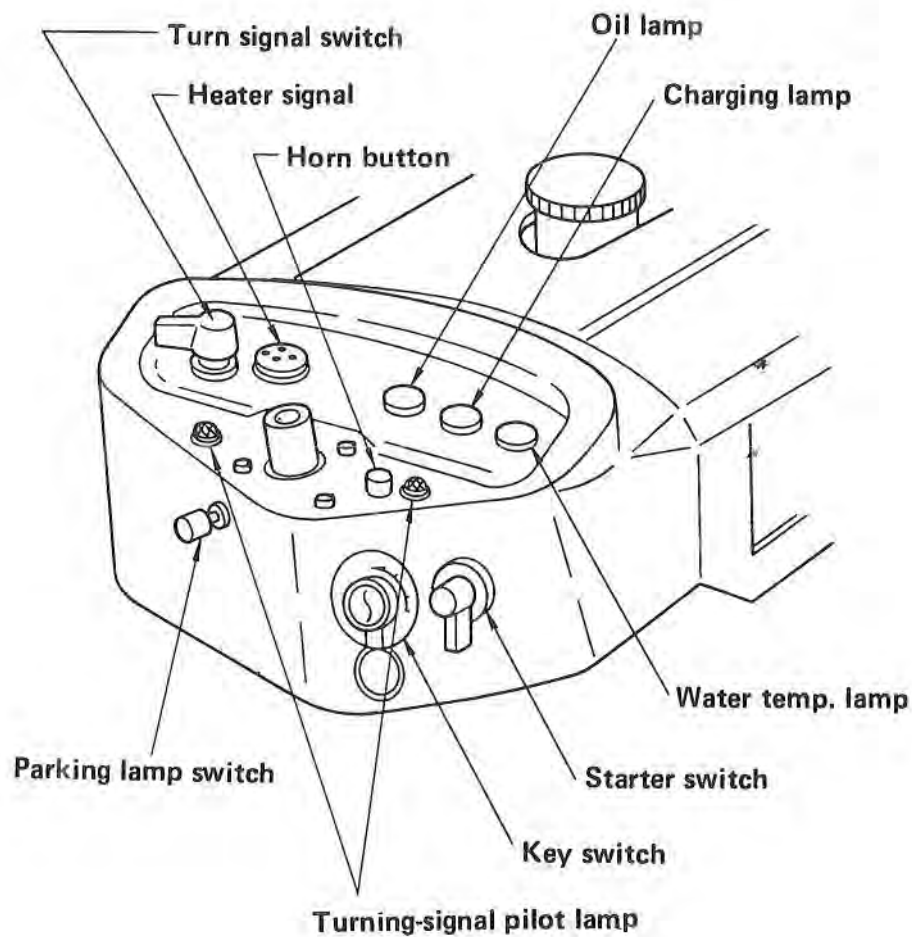

## 1. WARNING LAMPS AND SWITCHES



### • KEY SWITCH

The key switch is separated from the starter switch. The key can be removed and inserted only at the OFF position. At the three other positions it functions as follows:

- ON position:  
Electrical power is on.
-  position:  
Head lights on high beam.
-  Position  
Head lights on low beam.

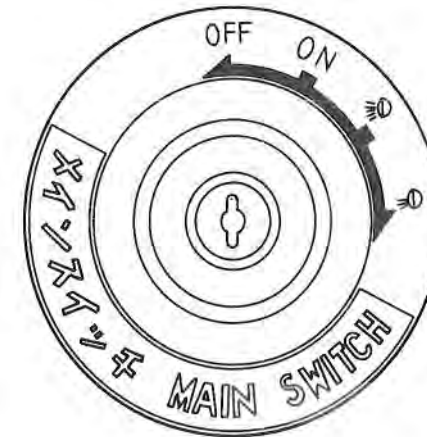

### CAUTION:

- Never set the key to OFF position during machine operation.
- Cover the key switch when the machine is not in operation.

- **STARTER SWITCH**



The starter switch has two operating positions: Start and Preheat.

- **“Start”**  
When turning the starter switch clockwise, the engine is started.  
By releasing the switch, it returns to its original position..
- **“Preheat”**  
When turning the switch counterclockwise, the preheating circuit is energized to preheat the combustion chamber.  
By releasing the switch, it returns to its original position.

- **HEATER SIGNAL**

Indicates preheating condition of the engine glow plug.  
When the combustion chamber is warmed up after turning the switch to “Preheat”, the signal becomes red.

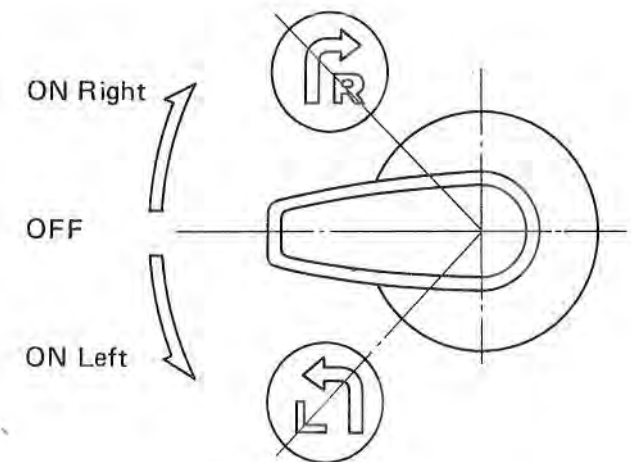
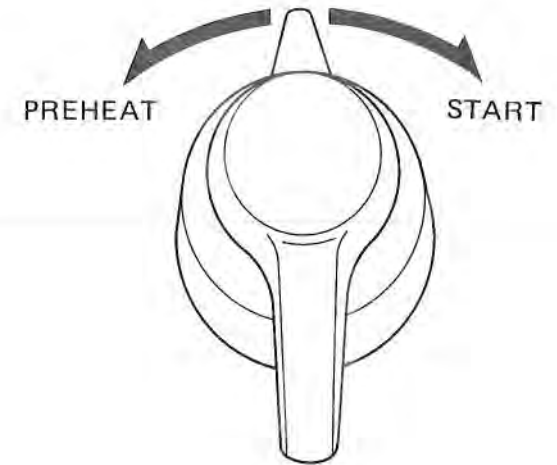

- **TURN SIGNAL SWITCH**

The turn signal is the flashing indicator type. When the switch is at horizontal position, the signal is not functioning.  
By turning the switch to  direction, the left turn signal flashes.  
By turning it to  direction, the right turn signal flashes.









- **HORN BUTTON**

When this button is pushed to "ON,  or  " position on the key switch, the warning horn sounds.

- **CHARGING LAMP**

The red colored oil lamp is ON at key switch positions of "ON,  and  ". During engine operation, the lamp remains off, indicating proper charging of electricity.

- **OIL LAMP**

The red colored oil lamp is ON at key switch positions of "ON,  and  ". During engine operation, the lamp remains off, indicating proper lubrication of the engine.

- **WATER TEMPERATURE LAMP**

When the engine is overheated, this lamp is lit for warning. If this lamp should glow during operation, immediately stop the machine, and run the engine at low speed to cool it off. When the water temperature goes down, the lamp goes off automatically.

## 2. CONTROL LEVERS AND PEDALS

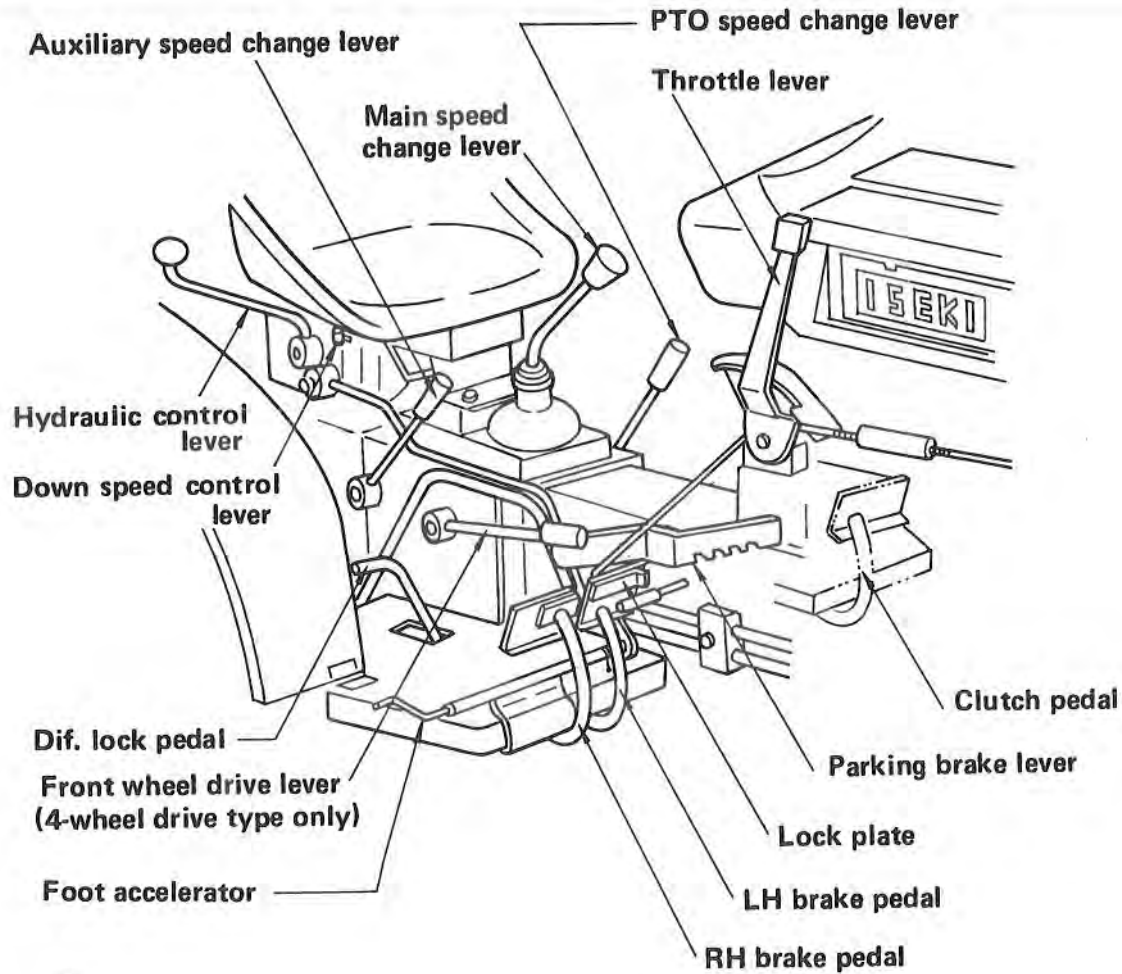

- **MAIN SPEED CHANGE LEVER**

The main speed change lever has three speeds in forward and one speed in reverse. Combined with the auxiliary speed change lever, the machine is capable of six forward speeds and two reverse speeds.

- **AUXILIARY SPEED CHANGE LEVER**

This lever has two speeds. By pushing the lever forward, 'High' speed is selected. By bringing it to the operator's side, 'Low' speed is selected.

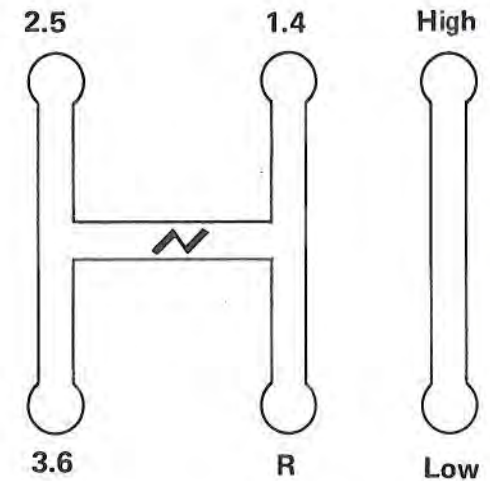

- **PTO SPEED CHANGE LEVER**

Three PTO shaft speeds can be selected by using this lever. If the rotary is mounted on the shaft, this lever changes the speeds of the tilling blades.

- **FRONT WHEEL DRIVE LEVER (4-WHEEL DRIVE TYPE ONLY)**

When driving the machine on inclines, through swamps or other areas requiring extra tractions, operate this lever to drive the tractor using all four wheels. By pushing down on the lever, the front wheels are engaged and put into drive. By pulling up on the lever, the front wheel drive is disengaged.



*CAUTION: When engaging front wheel drive, the clutch must be disengaged before operating the lever.*

- **THROTTLE LEVER**

By pulling the throttle lever to the operator's side, engine speed is increased. By pushing the lever forward, the speed slows down. When the lever is pushed in as far as the notched part of the lever guide, the engine becomes idling speed.

To stop the engine, push the lever forward further from this notched part.

- **CLUTCH PEDAL**

The clutch is disengaged when the clutch pedal is fully depressed.



**CAUTION:**

- *When disengaging the clutch, depress the clutch pedal quickly and fully. When engaging the clutch, gradually release the pedal.*
- *When changing speeds, disengage the clutch before operating the speed change lever.*
- *Never rest your foot on the clutch pedal during operation.*



- **BRAKE PEDALS**

Each brake pedal provides separate control over left rear wheel and right rear wheel braking.

By depressing the LH brake pedal, the left rear wheel brake is activated.

By depressing the RH pedal, the right rear wheel is stopped. When it is required to turn the machine sharply while moving at slow speed, use the pedals separately.

When traveling on the road or loading on a truck, however, interconnect both the pedals with the lock plate provided. Inspect the brake system to brake equally. If the braking effect is unequal, dangerous operation may result.

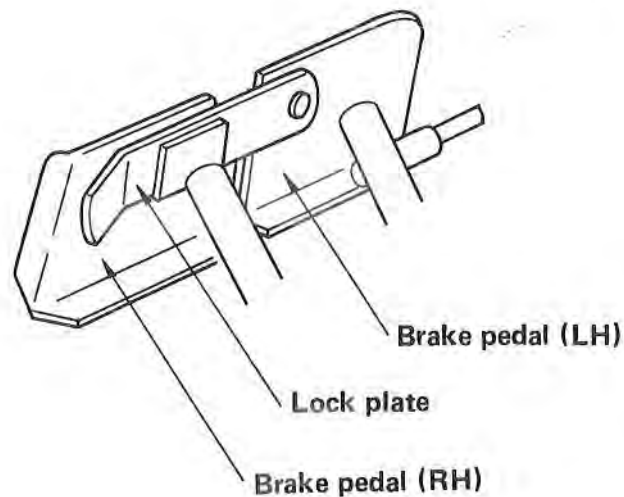

- **PARKING LEVER**

Interconnect both brake pedals, and keep them depressed. Pulling up the parking brake lever, engage the round bar at the left lower part of the brake pedal with the notch on the parking brake lever. This locks the brake pedal to park the machine.

When releasing the parking lever, depress the brake pedal and lower the parking lever until it makes contact with the stopper.

- **DIF. LOCK PEDAL**

The dif. lock is used to lock the differential, equalizing the rotational speeds of the left and right tires.

Should the rear tire slip or one tire turn idly, use this device to drive out of a rough field.

By depressing the pedal, dif. lock is applied. By releasing it, lock is disengaged.



**CAUTION:**

- *When traveling on the road, working with heavy load or working at high speed, never lock the differential, to avoid accident.*
- *When the difference in rotational speeds between both tires is extreme, operate the pedal after disengaging the clutch.*

### 3. OPERATION OF HYDRAULIC SYSTEM

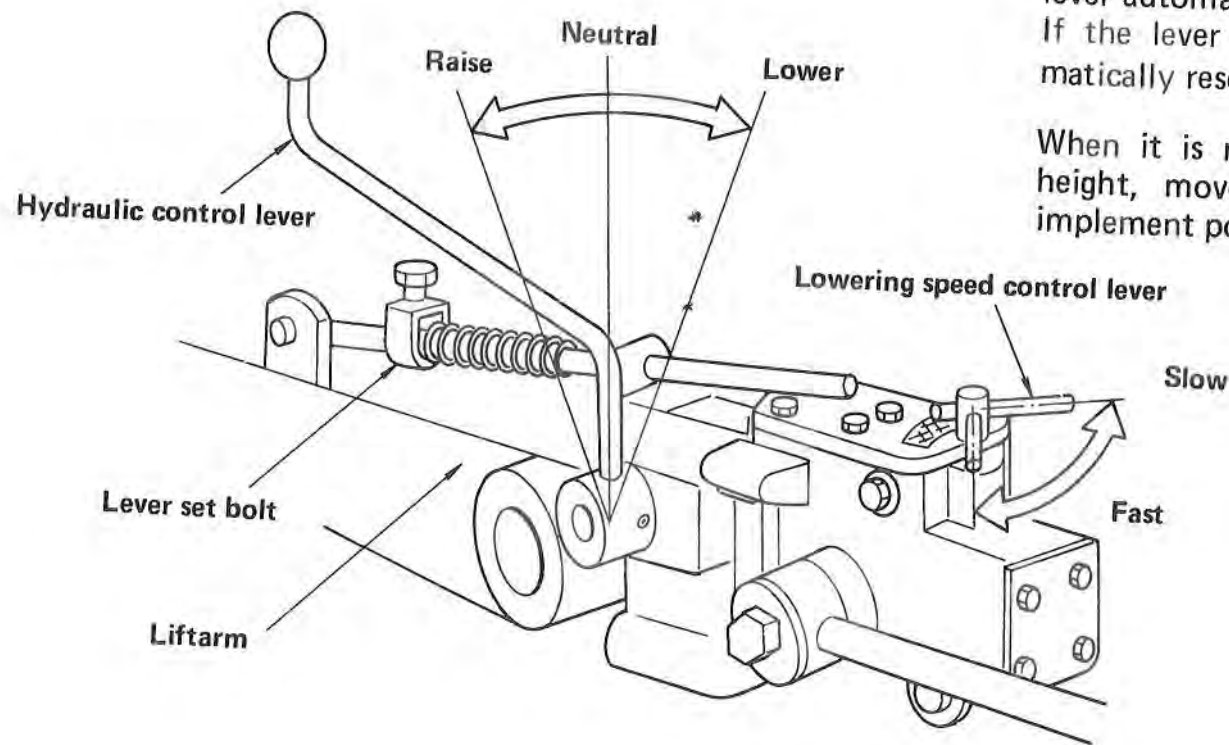

- **HYDRAULIC CONTROL LEVER**

The hydraulic control lever is moved to the rear "Raise" position to elevate the implement by hydraulic power. The lever should be moved forward to achieve the "Lower" position.

The implement is then lowered by its own weight.

When the implement is raised to its maximum position, the lever automatically return to its neutral position.

If the lever does not return to its neutral position automatically reset the lever by adjusting the lever set bolt.

When it is required to stop the implement at its desired height, move this lever set bolt to obtain the desired implement position.

● **LOWERING SPEED ADJUSTMENT LEVER**

Adjust the lowering speed to meet conditions and types of work done.

- Rotary work: Slow down the lowering speed.  
                  approx. 2 sec.
- Plowing:        Quicken the lowering speed.  
                  approx. 1 sec.

By turning the adjustment lever clockwise, the lowering speed accelerates.

By turning it counterclockwise, the speed is reduced.

The implement is not locked even when turning the lever fully counterclockwise. The lift arm may be lowered gradually.

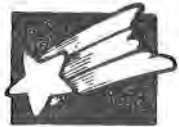

**CAUTION:**

- *When traveling on the road, set the lowering speed adjustment lever to its 'slowest' position, and apply a lock stay on the rotary to fix it in place.*
- *When changing rotary blades, removing entwined straw or plants and inspecting the implement, the engine must be turned off with the lowering speed adjustment lever set at the 'slowest' position. Also, lock the implement, using a lock stay to prevent accidents.*





## OPERATING THE TRACTOR





**CAUTION:**

*Before starting each day's work, preliminary checks should be made (See Paragraph 1, Section 7).*

## 1. STARTING THE ENGINE

- (1) Confirm that the main speed change lever and PTO speed change lever are set to Neutral positions.
- (2) Push back the stop lever to its original position.
- (3) Pull the throttle lever half way.
- (4) Depress the clutch pedal to disengage the clutch.



**CAUTION:**

*As a safety measure, the engine will not start unless the clutch pedal is depressed.*

- (5) Insert the key in the switch, and set it to the ON position. At this time, confirm that the oil charge lamp is lit.
- (6) Preheat the engine by turning the starterswitch counterclockwise. After the heater signal becomes red, release the key to return its original position. The heater signal becomes red in approx. 25 seconds. This operation is not necessary in hot weather or when the engine is already warm.

- (7) Start the engine by turning the starter switch clockwise. Immediately after starting the engine, release the starter switch.
- (8) After the engine starts, warm it up for 5 to 10 minutes at idling speed.



**CAUTION:**

- *Do not operate the starter motor more than 10 seconds continuously. If the engine fails to start, wait approx. 10 sec. before attempting to start it again.*
- *Never keep running the starter motor after the engine has started. Never run the motor during machine operation.*
- *When storing the machine in cold weather, remove the battery, and keep it in a warm place. This will help the engine to start easily the next time.*
- *The time required for preheating:*

<i>Outside temp. more than +5°C:</i>	<i>Approx. 20 sec.</i>
<i>Outside temp. more than +5°C~-5°C:</i>	<i>Approx. 30 sec.</i>
<i>Outside temp. less than -5°C:</i>	<i>Approx. 60 sec.</i>

## 2. STOPPING THE ENGINE

- (1) Slow down the engine speed by pushing the throttle lever fully forward, exceeding the notched part of the lever guide.
- (2) Set the key switch to the OFF position.



### CAUTION:

- Do not stop the engine when the engine is running at high speed.
- After long continuous operation, idle the engine for approximately 5 minutes before turning it off.
- If the key is left in the "ON" position, the battery may be discharged.  
Make it a practice to remove the key, after stopping the engine.

## 3. BASIC OPERATION OF STARTING THE TRACTOR

- (1) Depress the clutch pedal to disengage the clutch.
- (2) Set the speed change lever to desired position.
- (3) Release the parking brake lever.
- (4) Gradually pick up engine speed with the throttle lever.
- (5) Slowly release the clutch pedal. This starts the tractor.
- (6) Control tractor speed using the throttle lever.



### CAUTION:

- When traveling on the road, do not forget to interconnect both brake pedals. Single-side braking when driving at high speed is very dangerous.
- When the machine is in motion, keep your foot off of the clutch pedal and the brake pedal.

## ● BRAKING AND STOPPING THE TRACTOR

- (1) Slow down the engine speed using the throttle lever.
- (2) Depress the clutch pedal to disengage the clutch, and at the same time depress the brake pedal to stop the tractor.

## ● PARKING

- (1) Confirm that both brake pedals are interconnected, and depress the brake pedals and pull the parking brake lever.
- (2) Set the main speed change lever to neutral position.



### CAUTION:

- Never forget to apply the parking brake.
- When parking the tractor on a slope place blocks under the tires.

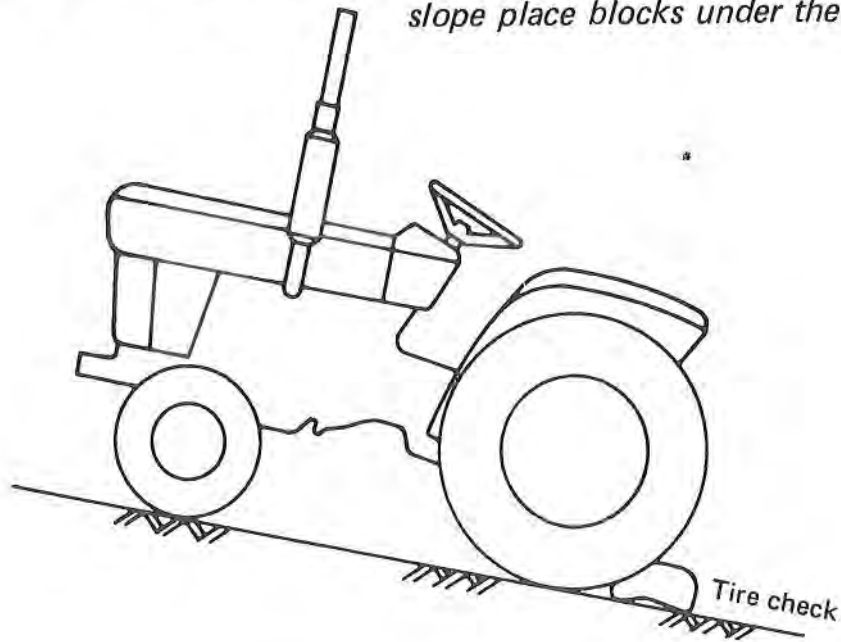

## ● SPEED SHIFTING

Never operate speed change levers when the machine is running. Before operating the lever, the tractor should be stopped. Before operating the PTO speed change lever, confirm that the PTO shaft is no longer rotated.

## ● TURNING THE TRACTOR

- (1) Remove the lock plate connecting both brake pedals for easy turning in working fields.
- (2) When turning the steering wheel, depress the brake pedals on the same side as the direction you are turning. This enables you to make a sharp turn.

## ● OPERATING ON A SLOPE

- (1) Starting on steep slope:
  1. Disengage the clutch by depressing the clutch pedal.
  2. Shift the speed change lever to desired speed.
  3. Depress the brake pedal.
  4. Set engine speed to intermediate speed using the throttle lever.
  5. Gradually release the clutch pedal until the clutch is in the half-engaged position.
  6. At the same time, release the brake pedal slightly.
  7. Pick up engine speed by pulling the throttle lever, release the brake pedal. At the same time, release the clutch pedal gradually. This starts the tractor.
- (2) Operation on down slope:

Use engine brake as much as possible.



### CAUTION:

- When turning the machine, slow down the engine speed and shift down the gear before beginning to turn the machine.



#### 4. OPERATION CHECK DURING WORK

**CAUTION:**

- *During operation, always observe warning lamps to confirm that each part is functioning correctly.*

- **WATER TEMPERATURE LAMP**

During operation, always pay attention to the water temperature lamp. If the temperature becomes abnormally high, the cooling system should be checked.

- **OIL LAMP**

If the oil lamp goes on during operation, it may indicate trouble with the lubricating system. Immediately stop operation to check and make corrections.

- **CHARGE LAMP**

If the charge lamp goes on during operation, electrical charging is not being made. There may be some problem in the charging system.

Check and correct the trouble.

If the cause of the trouble can not be located, have it looked at and repaired at service shop.



**STORAGE**

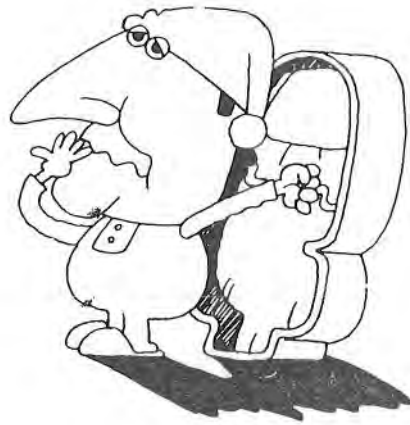

## 1. DAILY STORAGE

After each day's work is done, follow this procedure:

- Clean the tractor. Especially, after puddling or the like wash the machine thoroughly.



### CAUTION:

- *When washing the machine, do not apply compressed water on the electrical parts.*

- Fill the fuel tank to maximum level.
- Lower the implement to the ground.
- Store the machine indoors as much as possible. When storing the machine in an open space, cover it for protection.
- In cold weather, remove the battery and keep it in a warm place.
- Handle the engine coolant as follows:



### CAUTION:

- *If surrounding temperature is expected to go below 0°C (32°F), drain the coolant or add an anti-freeze solution. This will prevent a broken engine block.*

## 2. LONG-TERM STORAGE

Prior to storing the machine for more than a few months, thoroughly clean it. Then, carry out the following maintenance routine:

- Drain engine coolant from the radiator.  
Remove the drain cock at the left side of the radiator. Remove the radiator cap, and drain coolant completely. After draining, attach a caution tag indicating "NO WATER".
- Drain dirty engine oil. Put in new engine oil, and warm up the engine for 5 minutes to circulate the oil to every part of the engine.
- Inflate the tires a little more than the normally specified air pressure.
- Do not forget to lubricate all necessary parts. Apply grease or oil on all parts subject to rust.
- Check for loose bolts and nuts. Retighten, if necessary.
- Remove the balance weight or the like.
- Lower the implement to the ground.
- Select a dry place for storage. Cover the machine with a sheet.
- Remove the battery from the tractor. Recharge the battery. After adjusting the electrolyte level correctly, store it in a dry place out of direct sun light.
- To protect the engine from rusting, run the engine at 1000 to 1500 rpm for 5 to 10 minutes, once each month.
- Clutch should be disengaged completely as follows:

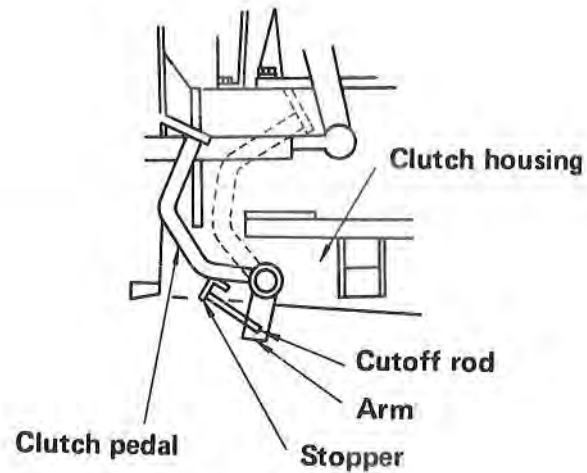

### 3. OPERATION AFTER LONG-TERM STORAGE

When operating the machine after long-term storage, observe the following precautions:

- Carry out preliminary checks.
- For correct machine service life and performance, practice the following warm up operation.

- (1) Pull the stop lever to shut the intake shutter.
- (2) Run the starter motor. Keep on running the starter motor after the oil lamp goes off.
- (3) Repeat the above operation above 2 to 3 times. Then start the engine. Warm up the engine at idling speed for half an hour.



# 6

## OPERATION IN COLD WEATHER



In cold weather, the tractor should be maintained with special care.

### 1. ENGINE OIL

As the temperature goes down, the engine oil tends to get hard. It is necessary to use SAE 10W oil in cold weather.

Use correct viscosity diesel engine oil consistent with surrounding temperature.

Surrounding Temp.	Type of Oil	
More than 20°C	SAE 30	
0°C to 20°C	SAE 20	or SAE 10W/30
Less than 0°C	SAE 10W	

### 2. ANTI-FREEZE SOLUTION

When it is expected that the surrounding temperature will drop below freezing, use anti-freeze solution.

- Before adding the anti-freeze solution, thoroughly clean the inside of the radiator.
- When preparing anti-freeze solution, follow the instructions on the label.
- Properly mix the anti-freeze solution with water, before adding to the cooling system.
- If the coolant level becomes low due to evaporation, add only water. If the coolant level becomes low due to leakage, add anti-freeze solution mixed with the same proportion of water used originally.
- Anti-freeze solution removes body paint. Take care not to spill it on the machine body.

### 3. BATTERY MAINTENANCE

In cold weather, the battery capacity becomes low. When it is discharged, the specific gravity of battery electrolyte becomes low.

- Check and service the charging system to maintain top charging performance.
- In cold weather, remove the battery from the machine, and store it in a warm place to keep it in good condition.

### 4. OPERATION IN SNOW OR ON FROZEN ROADS

When operating the tractor in snow or on frozen roads, never drive at high speeds; never accelerate quickly; never brake suddenly; never turn sharply . . . to avoid accidents.



**MAINTENANCE, INSPECTION AND ADJUSTMENT**



## 1. MACHINE PRELIMINARY CHECKS

Before starting day's work, check the machine as follows:  
(Refer to Paragraph 4, in this Section, "Chart of Periodical Inspection and Service".)

### ● AFTER OPENING THE ENGINE HOOD

#### (1) Engine Coolant

Removing the radiator cap, check the coolant level. If the level is lower than the filler mouth, replenish it with clean water.

Tighten the cap securely.



#### CAUTION:

- *Never use salty water or dirty water containing mud or grass.*

#### (2) Fan belt tension

When pushing the belt between pulleys, should be deflected by approx. 5 mm. not, adjust the belt.

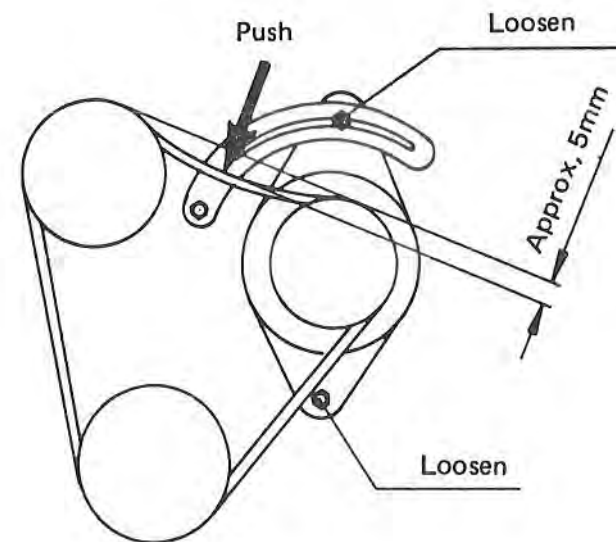



- **FROM OUTSIDE OF THE TRACTOR**

- (1) Oil Level Checks

When checking oil levels, refer to the "Lubrication Chart in Paragraph 3, this Section.

- Engine oil

The oil level gauge is at the right side of the engine. Remove the gauge, and check the engine oil level. Fully screw-in the gauge for checking.

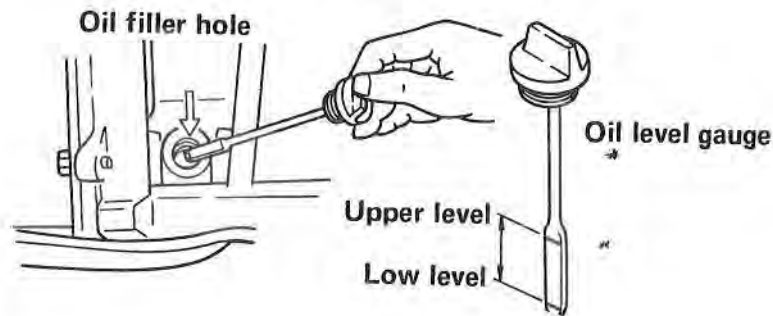

- Transmission oil
- Hydraulic oil
- Lubrication of each part

The above need not be checked daily. However, they should be checked periodically

- (2) Fuel

Check the fuel level in the fuel tank. Add fuel, if found low.

- (3) Looseness of Bolts, Nuts and Pins

Check bolts and nuts for looseness and check to see if any pins are missing. Pay special attention to the bolts and nuts in the steering system, and to the pins of the mounting system for the implement.

- **TIRES AND WHEELS**

(1) Tire air pressure greatly affects tractor performance and tire service life. It is very important to maintain air pressure in the tires at the specified pressure.

At the same time you check pressure, also check the tires for abnormal wear, cracks and damage.

Specified air pressure (kg/cm<sup>2</sup>)

	4-wheel drive		2-wheel drive	
	Front	Rear	Front	Rear
TX1000	1.2	1.0	1.6	1.0
TX1300	1.2	1.2	1.4	1.2
TX1500	1.2	1.2	1.4	1.2

- (2) Wheel Setting Bolt  
Confirm that all the wheel setting bolts for all 4 wheels are securely tightened.

## ● TIRES AND WHEELS

### (1) Steering Wheel

Confirm that there is no excessive play or deflection in the steering system. The standard free play is approximately 30 mm around the steering wheel circumference.

### (2) Brake Pedals

Confirm that both the left and right brakes display equal braking effects. Free play of the brake pedal should be 30 to 40 mm.

### (3) Electrical System

#### • Pilot lamp

Confirm that the oil lamp and charge lamp are functioning properly.

#### • Head light and working light

Confirm that the lights function properly. As for the head light, check if it is possible changes in the upper beam and lower beam.

#### • Turn signal light and horn

Confirm that the turn signal lights flash normally.

#### • Confirm that the horn works.

## 2. LUBRICATION

### ● LUBRICATION POINTS

#### (1) Engine oil

Check engine oil level with the level gauge at right side of the engine.

Recommended oil

More than 20°C

SAE 30

0°C to 20°C

SAE 20 or SAE 10W/30

Less than 0°C

SAE 10W

\* The drain plug is located at the lower part of the oil pan.



#### CAUTION:

- Use recommended engine oil.
- When replenishing the oil, use the same kind of oil as is in the engine.

#### (2) Transmission oil

Check transmission oil level by referring to the level gauge. When the oil level is low, add transmission oil through the filler hole below the operator's seat.

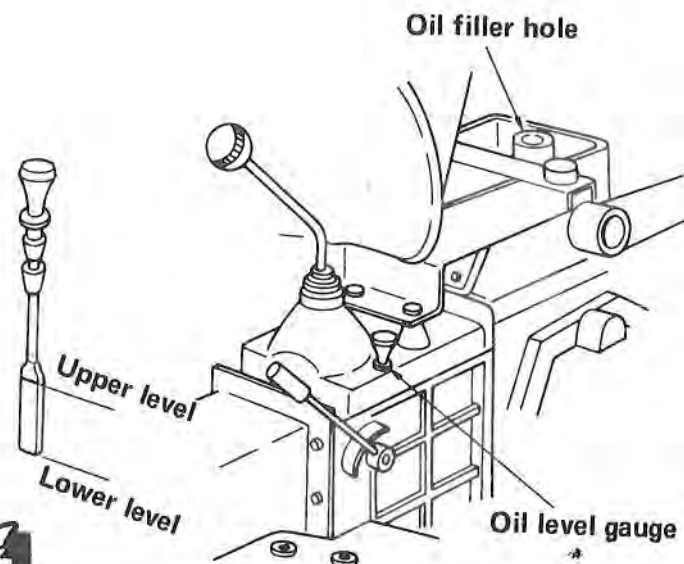

**CAUTION:**

- Use recommended gear oil SAE80.
- The Transmission oil is commonly used for hydraulic oil. As precision-made parts are used in the hydraulic system, never allow dust to get into the oil.
- Three drain holes are provided. Open these three drain holes to drain the oil.

**(3) Bevel Case and Front Gear Case Oil (4-Wheel Drive Type Machines only)**

- Add oil to the bevel case from the oil filler hold located at the front part of the bevel case.
- Add oil to the front gear case from the oil filler holes located on both sides of the front gear case.

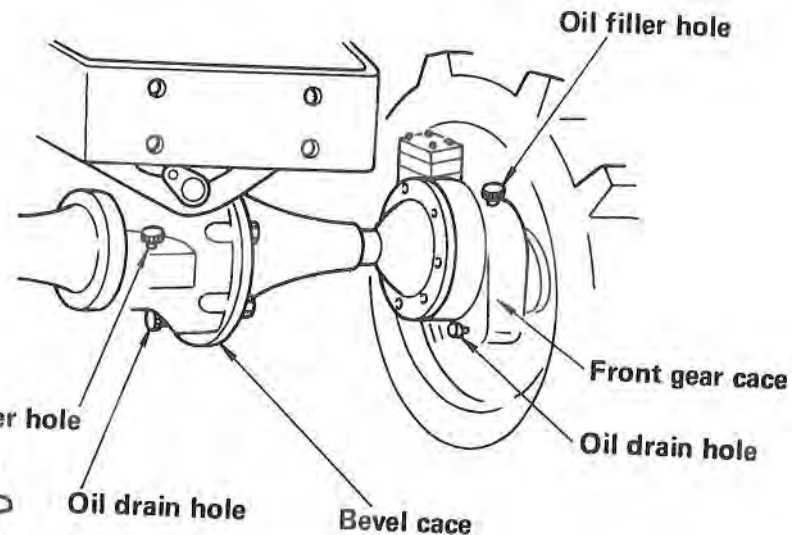

**CAUTION:**

- Use recommended gear oil SAE 80 or 90. However, never mix SAE 80 with SAE 90 oil.

**(4) Fuel**

Fuel has a great effect on engine performance. Therefore high quality fuel should be used.



**CAUTION:**

- If air enters the fuel system, power loss or difficulty in starting the engine may result. When fuel is exhausted during operation, or when cleaning the fuel filter, air bleeding should be accomplished without delay. As for air bleeding, refer to page 31.

### 3. LUBRICATION CHART (AND COOLANT)

### • FOUR WHEEL DRIVE TRACTORS



#### CAUTION:

- *Change the oil while the oil is warm, just after operation.  
Oil is easily to drain when it is warm.*

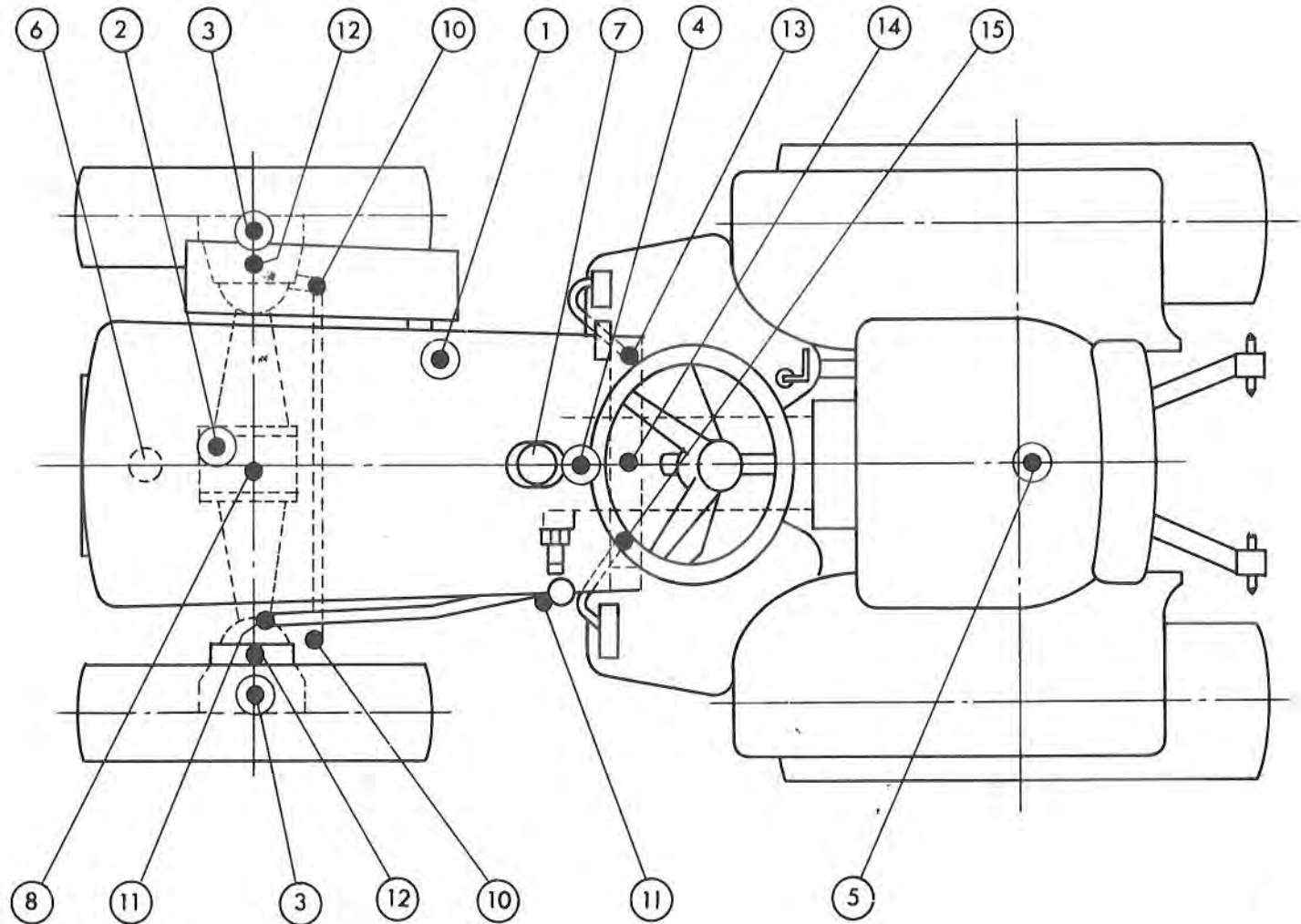



• TWO WHEEL DRIVE TRACTORS

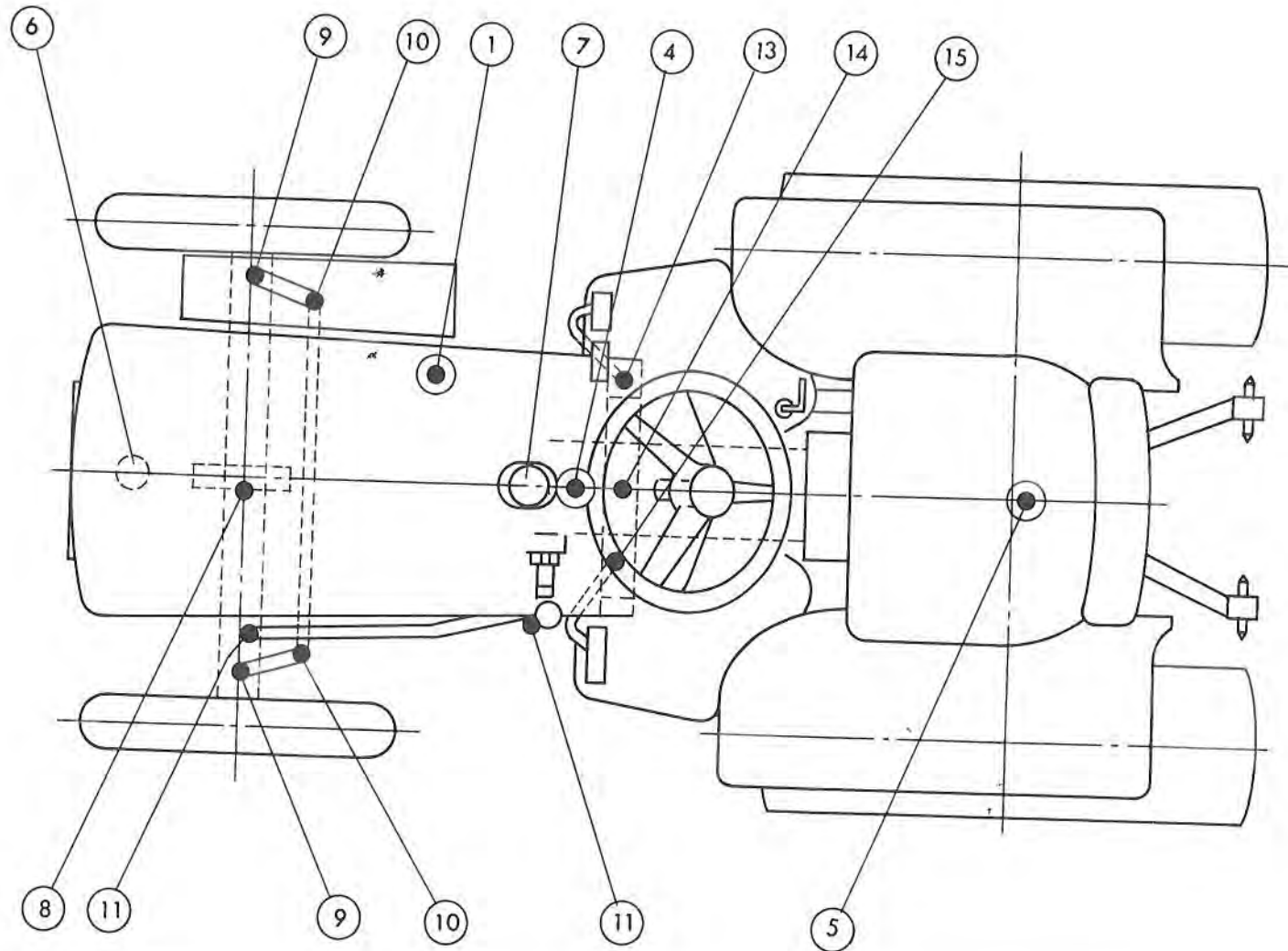

No.	Supplying points	Kinds of oil or water	Quantity (ℓ)						Remarks
			TX1000		TX1300		TX1500		
			4 wheel	2 wheel	4 wheel	2 wheel	4 wheel	2 wheel	
1	Engine	Engine oil	2.0	2.0	2.6	2.6	2.6	2.6	
2	Bevel case	Gear oil SAE 80 or 90	0.7	—	0.7	—	0.7	—	
3	Front gear case		0.25 (2 parts)	—	0.25 (2 parts)	—	0.25 (2 parts)	—	
4	Steering gear box	Gear oil SAE 80 or 90	Replenishment				(SAE 140)		
5	Transmission gear case	Gear oil SAE 80	9		13		16		
6	Radiator	Coolant *	4.2						
7	Fuel tank	Diesel light oil C JIS No. 2~3	12						
8	Center pivot		—	As req'd	—	As req'd	—	As req'd	
9	Knuckle spindle	} Grease	} As required						
10	Tierod end								
11	Drag rod end								
12	King pin								
13	Brake pedal								
14	Brake shaft								
15	Clutch pedal								

#### 4. PERIODICAL SERVICE TABLE

- Inspection, replenishment and adjustment
- Replacement
- △ Cleaning and washing
- ☆ Repair at service shop

	Items	Preliminary check	Periodical inspection and Operation hour (hour meter counter)											Inspection thereafter	Check standard at preliminary check				
			50	100	150	200	250	300	350	400	450	500	550			600			
Engine	Engine oil	○	●		●		●		●		●		●		●		●	Replace every 100 hours	Within level gauge  Filled up to pressure cap (not clogged) Full level  10mm can be pressed down with finger.  Tightened securely No damage or leaks 0.35mm (cooled)  120kg/cm <sup>2</sup>  Check broken wiring
	Air cleaner		△		△		△		●		△		△		△		△	Clean every 100 hours Change every 400 hours	
	Radiator coolant	○																Replace every year	
	Fuel	○																	
	Fuel filter		○	△	○	△	●	○	△	○	△	○	△	○	●			Clean every 100 hours Replace element every 300 hours	
	Cleaning inside the fuel tank			☆														Do every year	
	Fan belt	○					○				○							Check every 200 hours	
	Electrolyte level			○		○		○		○		○		○		○		Inspect every 100 hours	
	Oil filter		●		●		●		●		●		●		●		●	Replace every 100 hours	
	Tightening of bolts and nuts	○	☆																
	Damage and leaks	○																Change part	
	Valve clearance adjustment		☆								☆							Adjust every 400 hours	
	Engine idling adjustment		☆																
	Nozzle injection starting pressure		☆																
	Nozzle					☆				☆					☆			Check every 200 hours	
Starter, alternator & regulator									☆					☆			Adjust every 400 hours		
Glow plug									☆					☆			Check every 400 hours		
Compression pressures																	Check every 800 hours		

Items		Periodical inspection and Operation hour (hour meter counter)											Inspection thereafter	Check standard at preliminary check	
		50	100	150	200	250	300	350	400	450	500	550			600
Transmission gear oil		●		○		○		●		○		○		Inspect every 100 hours. Replace every 300 hours.	Both the brake work equally. Work securely.
Play of clutch pedal	○														
Play of brake pedal	○														
Efficiency of brake	○														
Working of levers	○														
Suction filter	△							△						Clean each 300 hours.	
Play of steering wheel	○														
Tire pressure TX1000	} 4-wheel drive	○													
TX1300		○													
TX1500		○													
TX1000	} 2-wheel drive	○													
TX1300		○													
TX1500		○													
Toe-in							○					○		2 ~ 4 m/m	
Greasing front wheel hub (2-wheel drive)													☆ Do each 900 hours		
Retightening front wheel bearing (2-wheel drive)															
Bevel case lubrication (4-wheel drive)							●					●			
Gear case lubrication (4-wheel drive)							●					●			

Items		Periodical Inspection and Operation hour (hour meter counter)											Inspection thereafter	Check standard at preliminary check		
		50	100	150	200	250	300	350	400	450	500	550			600	
Retightening steering ball joint							○							○	Adjust each 300 hours.	Tightened securely Proper working Tightened securely
Wheel clamping bolt	○															
Electric apparatus	○															
Adjustment of throttle							○							○	Adjust each 300 hours	
Clamping of bolts and nuts	○															
Oil leakage of clutch				*											Inspect every year by removing plug on the bottom clutch chamber.	
Grease-up		○	○	○	○	○	○	○	○	○	○	○	○	○	Replenish each 50 hours	
Check front gear case for entering of muddy water				*											After puddling, check by removing check plug at front gear case.	

## 5. INSPECTION AND ADJUSTMENT

### ● CLUTCH PEDAL

Free play of the clutch pedal decreases after the machine has been broken in.

Normal free play of the pedal is 15 to 20 mm.

If free play is less than normal, adjust it by loosening the lock nut on the adjustment bolt.

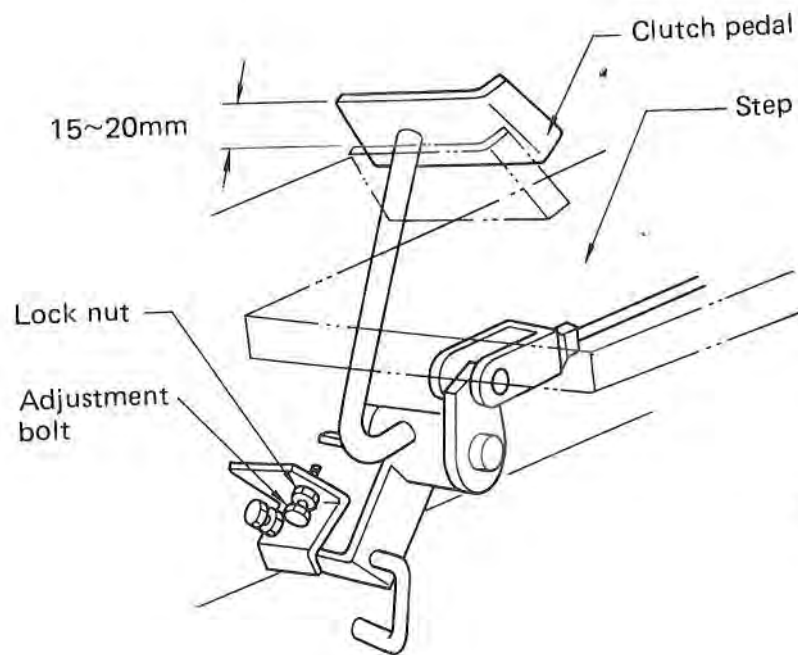

### ● BRAKE PEDAL

Specified free play of the brake pedal is 30 to 40 mm.

Always maintain free play as specified, by adjusting the rod.



### CAUTION:

*If the left and right brake systems provide an uneven braking effect the machine cannot be stopped in a straight position when both pedals are interconnected. Adjust both rods correctly to obtain the same braking effect in each system.*

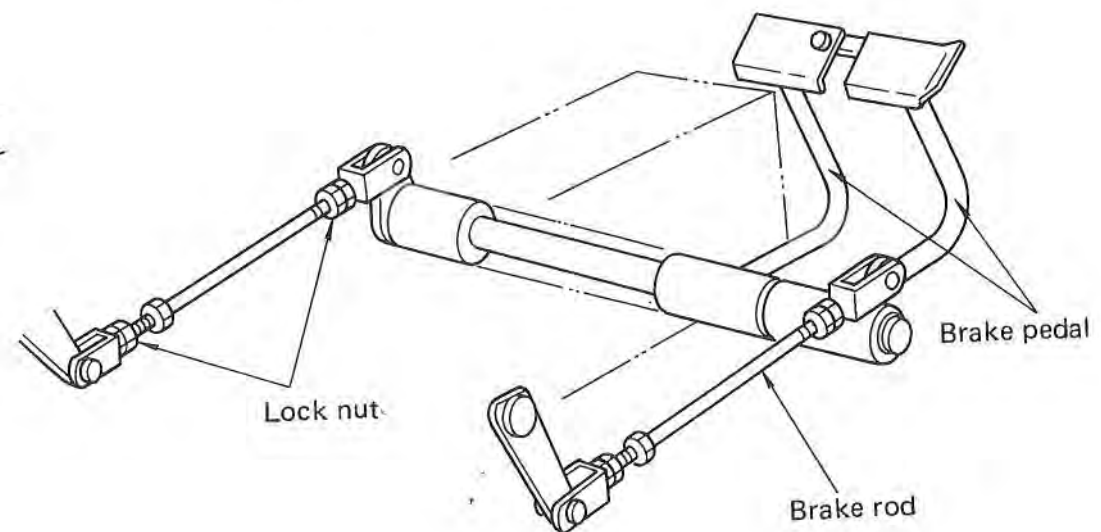



- **THROTTLE LEVER**

If movement of the throttle lever becomes loose or heavy, adjust the grooved nut.

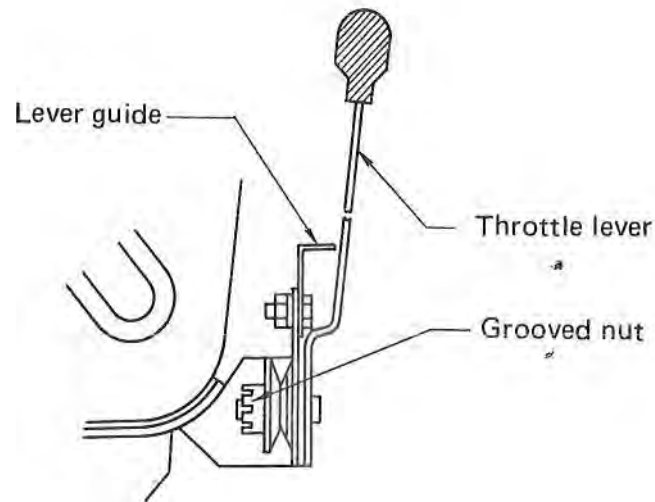

- **TOE-IN ADJUSTMENT**

Standard toe-in is specified to 2 – 4 mm. If not operating to this specification, loosen the lock nut to adjust.

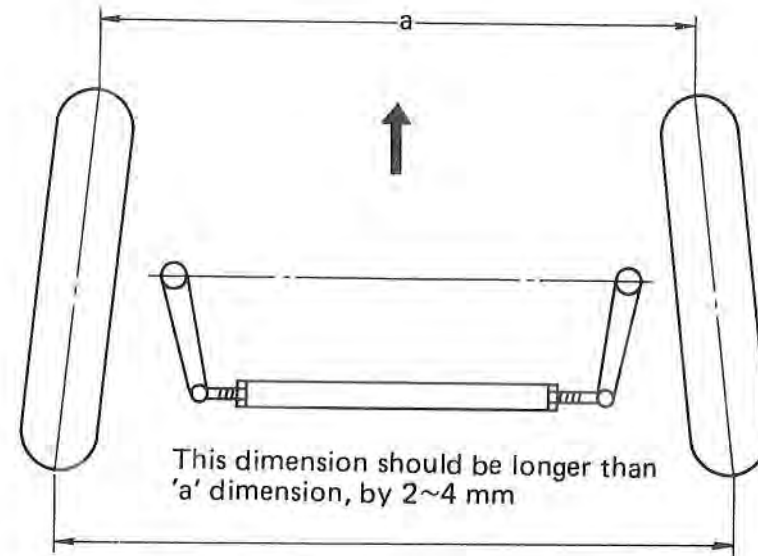

- **FREE PLAY OF STEERING WHEEL**

The specified free play of the steering wheel is approximately 30 mm around the circumference of the steering wheel. If free play is found to be excessive, adjust the steering wheel to meet the specification.

The major cause of excessive play is loosening of the ball joint setting part. Retighten this part. If retightening does not correct excessive play, adjust with the adjustment bolt shown in the figure below. By screwing-in the 'bolt, free play is decreased.

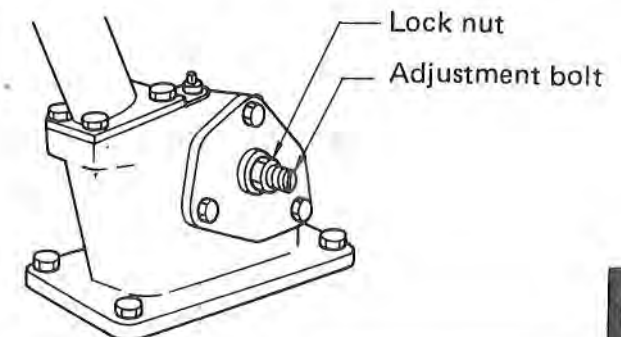

- **AIR BLEEDING FROM THE FUEL SYSTEM**

When screws or bolts of the fuel system are loosened, or fuel is exhausted during operation, air enters into the fuel system. This causes power loss or difficulty in starting the engine. Air bleeding should be accomplished to prevent this trouble.

- (1) Loosen an air bleeding screw (1) on the fuel filter, and bleed air.  
After the air is bled which is indicated by when there are no bubbles coming out, tighten the screw securely.

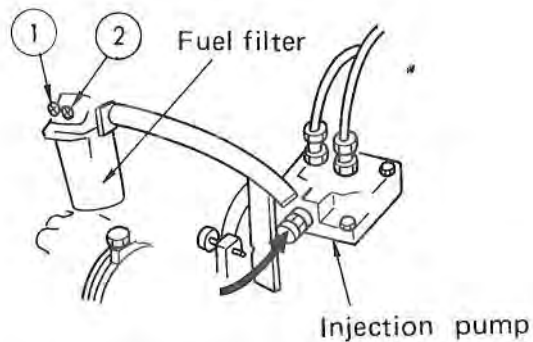

- (2) Loosen another air bleeding plug (2) on the fuel filter to bleed air. Then, loosen the air bleeding plug (3) to bleed air.  
After bleeding air, do not forget to retighten these plugs.
- (3) Run the starter motor for several seconds by pulling back fully on the throttle lever. This bleeds air from the injection pipe and nozzle.

- **ADJUSTING FRONT AND REAR TREADS**

Following is an explanation of adjustment of treads for each tractor model.



**CAUTION:**

- *When adjusting the tread, always keep safety in mind.*
- *All bolts and nuts should be securely tightened.*

# (1) FOUR WHEEL DRIVE TRACTOR

	TX1000F	TX1300F	TX1500F
A	700	740	780
B	800	840	880

Unit: mm

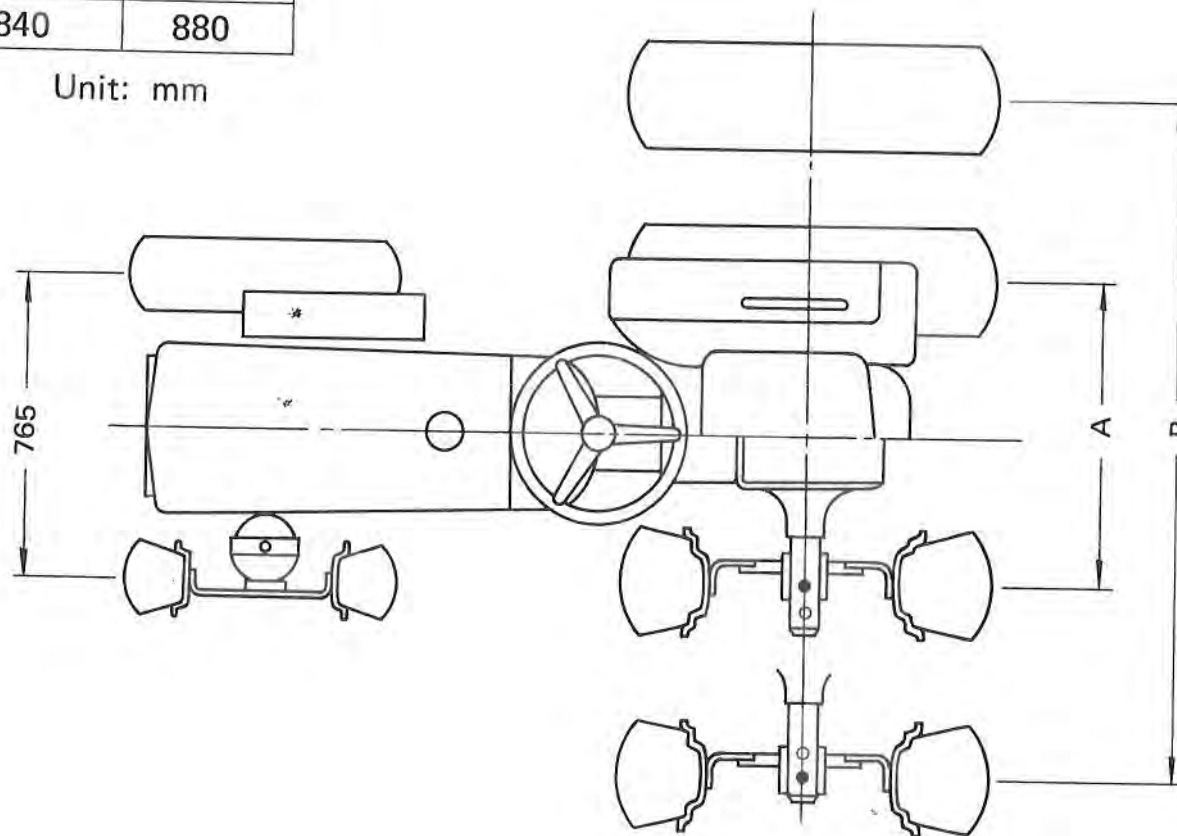

## (2) TWO WHEEL DRIVE TRACTOR

	TX1000	TX1300	TX1500
A	700	740	780
B	800	840	880

Unit: mm

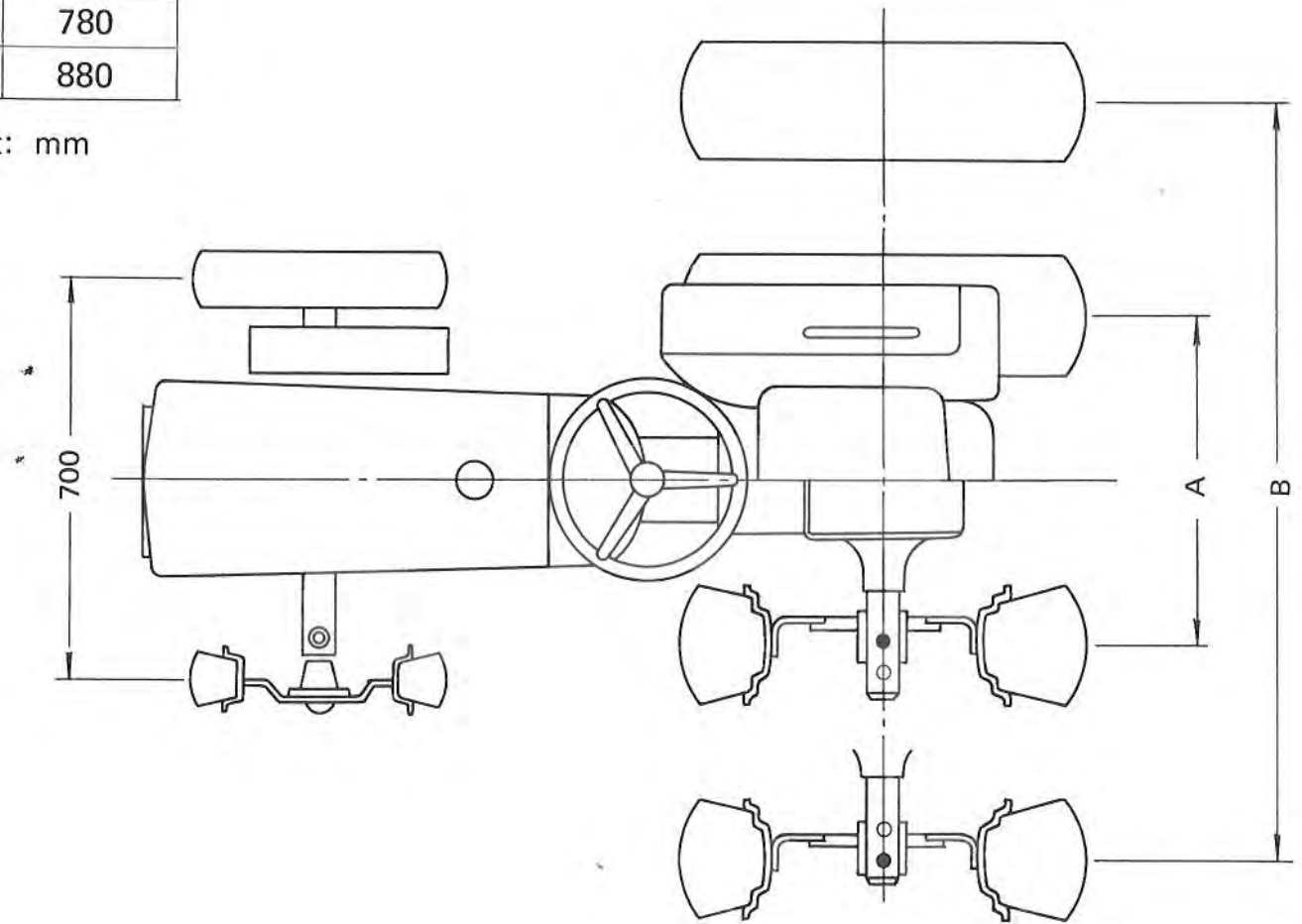

- **ADJUSTING OPERATOR'S SEAT**

The operator's seat can be adjusted into two positions front-to-rear. Adjust the seat by removing the pin after removing the hair pin.

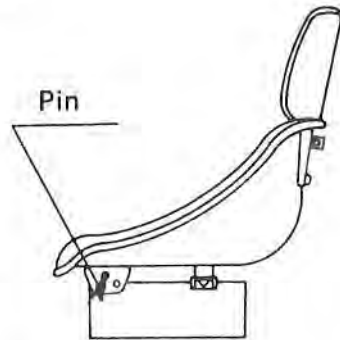

- **BATTERY INSPECTION**

The battery is the only power source for starting the engine and electrical system of the tractor. Incorrect battery maintenance shortens its useful life. To prolong the service life with best performance, adequate maintenance is required.



**CAUTION:**

- *If electrical energy in the battery is discharged beyond a certain point, the battery cannot start the engine. Also, head lights will not light brightly. When the battery is in this condition, it may be impossible to recover battery performance even by recharging it.*

*Always maintain the battery in as fully charged condition as possible.*

*Battery electrolyte will evaporate naturally or during recharging. If the battery electrolyte is insufficient, the battery is damaged. If the electrolyte level is too high, it will spill out from the battery resulting in corrosion of the machine body. It is very important to maintain the specified electrolyte level.*

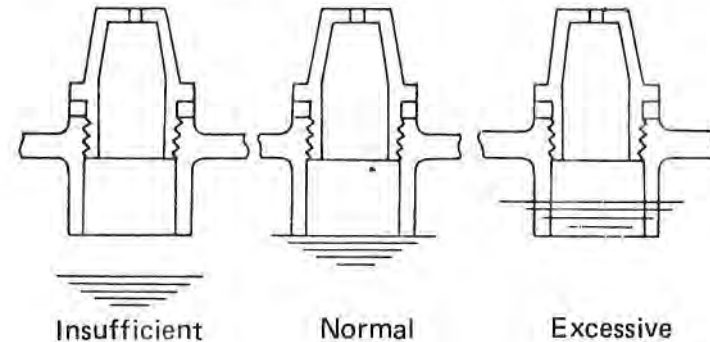

When electrolyte level becomes low;

- (1) By natural evaporation – Replenish with diluted water.
- (2) By spilling out – add sulphuric acid. Have done at service station or battery shop.

When the battery is fully charged, specific gravity of the electrolyte should be 1.26 at 20°C.

- **INSPECTING AND SERVICING THE AIR CLEANER**

The following checking and servicing procedure should be accomplished periodically.

- Loosening the wing nut, remove the cover and take out the element for cleaning.

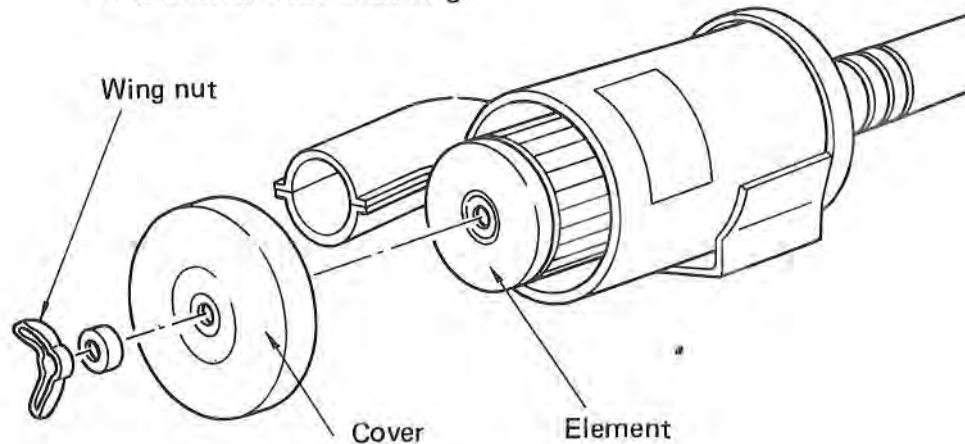

(a) When dry dust sticks:

Holding the element in your hand, tap it lightly to remove the dust.

(b) When wet dust or oil sticks:

Soak the element in a neutral cleaning solvent mixed with water. After soaking the element for half an hour, wash it gently. Then, air dry the element.



**CAUTION:**

*Service the air cleaner in accordance with the instructions on the caution plate attached to the air cleaner.*

- **RADIATOR**

Before each day's activities, fill the radiator with coolant to the full level. It is very important to make it a habit to check the coolant level every day before work.

(1) Pressure cap

The pressure cap is completely sealed by spring force. If the cap is not closed correctly, or the washer is not mounted properly, the coolant may leak, thereby resulting in a rapid decrease of the coolant level.



**CAUTION:**

- *When opening the pressure cap during high load operation or just after work, boiled water may flush out, resulting in scalding. Therefore, for your safety, wait more than 10 minutes after stopping the engine, before opening the cap.*
- *When draining the engine coolant, the pressure cap should also be removed.*

(2) Grass, straw, dust, insects or the like may be stuck to the net in front of the radiator after tractor operation. This results in poor cooling performance. In this case, the water temperature rises abnormally high. Remove the net, and remove foreign materials periodically.

(3) Anti-freeze solution  
Refer to Section 6 in this Manual.



# 8

## PROBLEM SOLVING



	Problem	Possible Causes	Corrective Action
E N G I N E	Starter motor fails to run.	<ul style="list-style-type: none"> <li>● Clutch pedal not depressed</li> <li>● Discharged battery</li> <li>● Loose wire connections</li> <li>● Defective starter switch</li> <li>● Defective starter motor</li> </ul>	<ul style="list-style-type: none"> <li>● Depress clutch pedal.</li> <li>● Recharge battery.</li> <li>● Correct.</li> <li>● Apply grease.</li> <li>● Repair or replace the switch.</li> <li>● Repair or replace starter motor.</li> </ul>
	Starter motor runs slowly.	<ul style="list-style-type: none"> <li>● Discharged battery</li> <li>● Improper grounding</li> <li>● Improper viscosity engine oil used</li> </ul>	<ul style="list-style-type: none"> <li>● Recharge battery</li> <li>● Clean and tighten grounding terminal.</li> <li>● Use oil of correct viscosity.</li> </ul>
	Starter runs. Engine does not start.	<ul style="list-style-type: none"> <li>● Air trapped in fuel system</li> <li>● Fuel filter clogged</li> <li>● No fuel injection</li> <li>● Engine trouble</li> </ul>	<ul style="list-style-type: none"> <li>● Bleed air.</li> <li>● Clean or replace the filter.</li> <li>● Open fuel cock to inject fuel.</li> <li>● Repair at service station.</li> </ul>
	Engine runs irregularly	<ul style="list-style-type: none"> <li>● Air trapped in fuel system</li> <li>● Clogged injection nozzle</li> <li>● Fuel leaks from fuel piping</li> <li>● Uneven fuel injections</li> </ul>	<ul style="list-style-type: none"> <li>● Bleed air.</li> <li>● Clean or replace.</li> <li>● Tighten clamps. Replace pipes. Polish and tighten copper washer.</li> <li>● Repair at service station.</li> </ul>
	Engine stops at low speed.	<ul style="list-style-type: none"> <li>● Defective injection pump</li> <li>● Improper valve clearance</li> <li>● Defective injection nozzle</li> </ul>	<ul style="list-style-type: none"> <li>● Repair at service station.</li> </ul>
	Engine over-runs.	<ul style="list-style-type: none"> <li>● Dust in the governor</li> <li>● Oil burnt in combustion chamber</li> </ul>	<ul style="list-style-type: none"> <li>● Repair at service station.</li> </ul>
	Engine stops suddenly.	<ul style="list-style-type: none"> <li>● Insufficient fuel</li> <li>● Clogged fuel filter</li> <li>● Defective injection nozzle</li> <li>● Engine seizure due to poor lubrication</li> </ul>	<ul style="list-style-type: none"> <li>● Add fuel. Bleed air.</li> <li>● Replace fuel filter.</li> <li>● Repair at service station.</li> <li>● Repair at service station.</li> </ul>
	Engine overheats.	<ul style="list-style-type: none"> <li>● Lack of engine coolant</li> <li>● Loosened or damaged fan belt</li> <li>● Clogged radiator cores</li> <li>● Lack of engine oil</li> </ul>	<ul style="list-style-type: none"> <li>● Add coolant. Check for coolant leaks.</li> <li>● Adjust or replace the belt.</li> <li>● Clean.</li> <li>● Check and replenish oil.</li> </ul>
	High fuel consumption	<ul style="list-style-type: none"> <li>● Clogged air cleaner</li> <li>● Improper valve clearance</li> <li>● Coolant temperature too low</li> <li>● Improper fuel</li> </ul>	<ul style="list-style-type: none"> <li>● Clean air cleaner element.</li> <li>● Correct</li> <li>● Apply cover on radiator.</li> <li>● Change to correct fuel.</li> </ul>

	Problems	Possible Causes	Corrective Action
E N G I N E	High oil consumption	<ul style="list-style-type: none"> <li>● Low oil viscosity</li> <li>● High oil level</li> <li>● Oil leakage</li> </ul>	<ul style="list-style-type: none"> <li>● Use oil to suit surrounding temperature.</li> <li>● Adjust to specified level.</li> <li>● Check and repair.</li> </ul>
	Low engine power	<ul style="list-style-type: none"> <li>● Clogged or burnt injection nozzle.</li> <li>● Carbon deposit on the nozzle</li> <li>● Low compression pressure.</li> <li>● Gas leakage from valve seat</li> <li>● Improper valve clearance</li> <li>● Improper injection timing</li> <li>● Lack of fuel</li> <li>● Clogged air cleaner</li> </ul>	<ul style="list-style-type: none"> <li>● Repair at service station.</li> <li>● Check and correct fuel system.</li> <li>● Clean air cleaner element.</li> </ul>
	Oil lamp flashes during operation.	<ul style="list-style-type: none"> <li>● Lack of engine oil</li> <li>● Low viscosity of engine oil</li> <li>● Defective oil pressure switch</li> <li>● Defective oil pump</li> <li>● Clogged oil filter element</li> </ul>	<ul style="list-style-type: none"> <li>● Add oil.</li> <li>● Use specified viscosity oil.</li> <li>● Replace the switch.</li> <li>● Repair at service station.</li> <li>● Replace the element.</li> </ul>
	Charge lamp flashes during operation.	<ul style="list-style-type: none"> <li>● Defective wiring</li> <li>● Defective alternator</li> <li>● Defective regulator</li> <li>● Defective battery</li> <li>● Lack of battery electrolyte</li> <li>● Loosened or damaged fan belt</li> </ul>	<ul style="list-style-type: none"> <li>● Check and correct loose terminals, shorts, etc.</li> <li>● Repair at service station.</li> <li>● Repair at service station.</li> <li>● Change battery.</li> <li>● Add electrolyte.</li> <li>● Adjust or replace the belt.</li> </ul>
C L U T C H	Clutch slips.	<ul style="list-style-type: none"> <li>● Improper pedal adjustment</li> <li>● Worn or burnt clutch lining</li> </ul>	<ul style="list-style-type: none"> <li>● Adjust free play of pedal.</li> <li>● Repair at service station.</li> </ul>
	Clutch does not disengage.	<ul style="list-style-type: none"> <li>● Seized clutch lining</li> <li>● Improper clutch pedal adjustment</li> </ul>	<ul style="list-style-type: none"> <li>● Repair at service station.</li> <li>● Adjust free play of pedal.</li> </ul>
B R A K E S Y S T E M	Poor braking Uneven braking	<ul style="list-style-type: none"> <li>● Excessive brake pedal free play</li> <li>● Oil leaks in brake chamber</li> <li>● Worn or burnt brake lining</li> <li>● Different brake distances in left and right pedals</li> </ul>	<ul style="list-style-type: none"> <li>● Adjust.</li> <li>● Repair at service station.</li> <li>● Relining at service station.</li> <li>● Adjust.</li> </ul>
	Slow return of brake pedal	<ul style="list-style-type: none"> <li>● Damaged brake return spring</li> <li>● Lack of grease on sliding parts</li> </ul>	<ul style="list-style-type: none"> <li>● Replace the spring.</li> <li>● Apply grease after removing rust.</li> </ul>

	Problems	Possible Causes	Corrective Actions
HYDRAULIC SYSTEM	Hydraulic system does not raise.	<ul style="list-style-type: none"> <li>● Lack of hydraulic oil</li> <li>● Air taken in from intake pipings</li> <li>● Clogged suction filter</li> <li>● Defective hydraulic pump</li> <li>● Defective control valve</li> <li>● Damaged cylinder</li> </ul>	<ul style="list-style-type: none"> <li>● Add to specified level.</li> <li>● Retighten joints.</li> <li>● Replace cracked pipe.</li> <li>● Replace damaged O-ring.</li> <li>● Clean the filter.</li> <li>● Repair at service station.</li> <li>● Repair at service station.</li> <li>● Replace at service station.</li> </ul>
	Oil leakage form piping	<ul style="list-style-type: none"> <li>● Loosened pipe joints</li> <li>● Cracked pipe</li> </ul>	<ul style="list-style-type: none"> <li>● Retighten joints.</li> <li>● Replace pipe at service station.</li> </ul>
	Buzzer-sound is heard at relief valve when placing hydraulic lever to 'raise'.	<ul style="list-style-type: none"> <li>● Dislocated stopper</li> <li>● Improper setting of auto-return device</li> </ul>	<ul style="list-style-type: none"> <li>● Adjust the position.</li> <li>● Adjust the position.</li> </ul>
	Hydraulic system does not lower.	<ul style="list-style-type: none"> <li>● Lowering speed adjustment lever is locked.</li> <li>● Defective control valve</li> <li>● Damaged cylinder</li> <li>● Burnt lift shaft rotating part</li> </ul>	<ul style="list-style-type: none"> <li>● Set to "lower" position.</li> <li>● Repair at service station.</li> <li>● Replace at service station.</li> <li>● Repair at service station.</li> </ul>
STEERING SYSTEM	Heavy steering Difficult steering	<ul style="list-style-type: none"> <li>● Improper toe-in</li> <li>● Improper tire inflation</li> <li>● Deflected rod ends</li> </ul>	<ul style="list-style-type: none"> <li>● Adjust toe-in.</li> <li>● Inflate tires evenly.</li> <li>● Retighten or replace parts.</li> </ul>
	Excessive steering wheel free play	<ul style="list-style-type: none"> <li>● Worn steering shaft</li> <li>● Worn metal</li> <li>● Deflected rod ends</li> </ul>	<ul style="list-style-type: none"> <li>● Adjust by adjustment bolt.</li> <li>● Correct at service station.</li> <li>● Retighten.</li> </ul>
ELECTRICAL SYSTEM	Battery does not charge	<ul style="list-style-type: none"> <li>● Defective wiring</li> <li>● Defective alternator</li> <li>● Defective regulator</li> <li>● Loose or damaged fan belt</li> <li>● Poor maintenance of battery</li> </ul>	<ul style="list-style-type: none"> <li>● Check and correct loosened or dirty terminal, shorts, etc.</li> <li>● Repair at service station.</li> <li>● Repair or replace at service station.</li> <li>● Adjust or replace belt.</li> <li>● Correct loose or rusted terminals.</li> <li>● Correct electrolyte level.</li> </ul>
	Weak head light Head light does not go on.	<ul style="list-style-type: none"> <li>● Discharged battery</li> <li>● Improper wiring</li> <li>● Broken bulb</li> <li>● Melted fuse</li> <li>● Defective connection</li> </ul>	<ul style="list-style-type: none"> <li>● Recharge battery.</li> <li>● Check and correct.</li> <li>● Replace bulb.</li> <li>● Correct the wiring, and replace fuse.</li> <li>● Check and correct.</li> </ul>

	<b>Problems</b>	<b>Possible Causes</b>	<b>Corrective Actions</b>
<b>ELECTRICAL SYSTEM</b>	Horn does not sound.	<ul style="list-style-type: none"> <li>● Defective horn button</li> <li>● Defective wiring</li> <li>● Defective horn</li> </ul>	<ul style="list-style-type: none"> <li>● Replace button.</li> <li>● Repair.</li> <li>● Repair or correct.</li> </ul>
	Turn indicator does not flash.	<ul style="list-style-type: none"> <li>● Broken bulb</li> <li>● Defective flasher unit</li> <li>● Defective connection</li> </ul>	<ul style="list-style-type: none"> <li>● Replace bulb.</li> <li>● Replace the unit.</li> <li>● Check and correct terminal connection.</li> </ul>

9

SAFETY PRECAUTIONS.





AS THE MANUFACTURER OF THIS TRACTOR, ISEKI HAS A RESPONSIBILITY TO DESIGN AND ASSURE SAFETY OF THE MACHINE. IN ACTUAL WORK, HOWEVER, ACCIDENTS CANNOT BE PREVENTED WITHOUT THE FULL CO-OPERATION OF THE OPERATOR.

TO PREVENT ACCIDENTS PLEASE READ THE FOLLOWING IMPORTANT PRECAUTIONS AND KEEP THEM IN MIND TO ASSURE SAFE MACHINE OPERATION. ISEKI ASKS YOU TO BE A SAFE OPERATOR. WE SAY THAT "THE BEST SAFETY DEVICE IS A CAREFUL OPERATOR."

## 1 GENERAL PRECAUTIONS

### PERSONS LISTED BELOW MUST NOT OPERATE THE MACHINE:

- Persons suffering from mental disease
- Drunken persons
- Persons who cannot be expected to operate the machine properly because of fatigue, illness or the influence of medicines and drugs.
- Pregnant women
- Young persons prohibited from driving by law

### PROTECTIVE DEVICES

- ★ A helmet must be worn during work, especially when traveling on the road or handling materials near the operator's head.
- ★ To protect against accidents from entwined cloth, hair or the like, suitable working clothes and a hat should be worn.
- ★ When working in the fields with poisonous gas or dust, use a protective mask or similar covering.
- ★ When spraying agricultural chemicals, use a mask and clothes to protect the respiratory organs.
- ★ When working the machine under conditions of severe vibration, use suitable ear plugs.
- ★ Periodically check and maintain these protective materials, and prepare them for effective use.

## 2. MAINTENANCE OF THE TRACTOR

- (1) The tractor should be checked and serviced before and after each day's work. Furthermore, periodical checks and servicing should be accomplished to maintain the tractor and implement in best condition for safe work.
- (2) When carrying out maintenance of the tractor and implements, special attention must be paid to the control devices and protective devices of the tractor and implements.
- (3) When servicing the tractor and implements, select a place where there is no traffic, on level ground. If servicing indoors with the engine running, do not forget to assure proper ventilation.
- (4) Before inspecting and adjusting the machine, stop the engine, apply the parking brake, and apply a block under the tires if needed. If it is necessary to work under the heavy implement in raised position, be sure that the hydraulic system is securely locked.
- (5) While servicing the machine with the engine stopped, take measures to assure that the engine does not start accidentally.
- (6) When working under the tractor or with the machine raised, apply blocks under the tires which are on the ground.  
Confirm that the supporting device has sufficient strength and meets those specifications required to support the machine. When using a jack, apply it in a secure place, like under the gear box. The jack must be placed on firm and flat ground.
- (7) Before removing protective devices from the tractor or implement for servicing, confirm that the function serviced by the device is turned off.  
Do not forget to reinstall the protective device serviced to its original position.
- (8) Never add fuel when the engine is running or heated. Never smoke a cigaret or start fire around a fuel storing area when adding fuel.  
When adding fuel at night, never use an open fire for illumination.
- (9) Do not open the radiator cap when the engine is hot. If it is necessary to supply coolant in the radiator when the engine is hot, special care is needed to protect against boiled water or vapor which can be coming out of the radiator.  
If cool water is added to an overheated radiator, the radiator may break. Special caution is required.
- (10) Check the battery before starting the engine. Do not bring any fire near the battery. When removing the battery plugs, do not touch with battery electrolyte.
- (11) Correctly store and use service tools.  
Necessary service tools should be stored in a handy place on the tractor.

### 3. PRECAUTIONS AGAINST FIRE

- (1) During work
  - a. Never bring inflammable materials near the engine.
  - b. Pay careful attention to avoid fire.
- (2) Storing of dangerous matter
  - a. When storing devices suspected to be dangerous, put a cover on them.  
Take other necessary safety measures.
  - b. Fuel must be stored in a safe place.  
'No Fire' signs should be posted in the area.
  - c. Inflammable materials must be stored in a safe place.

### 4. PRECAUTIONS WHEN HANDLING IMPLEMENT

- (1) The implement must be mounted and removed on level ground.  
Handle the implement safely and correctly.  
When working at night, handle the implement carefully, using suitable illumination.
- (2) When mounting the implement by moving the tractor, do not stand between the tractor and the implement.  
When coupling the tractor with the implement, select a place to work where there is sufficient room to move away quickly in an emergency. Be sure the parking brake is applied during the coupling process.
- (3) After installation, confirm that the mounting pin is securely locked.
- (4) The universal joint must be installed as straight as possible.
- (5) When the heavy implement is mounted, assure machine balance by using the balance weight.

- (6) When the operator leaves the machine to adjust the implement, be sure to apply parking brake, with the engine turned off. Furthermore, confirm that power to the driving shaft is completely disengaged before you get off the machine.
- (7) Do not get under the implement.  
Never place your foot under the implement.
- (8) Adjust the cover on the rotary so that soil and stone will not spread too much around it during rotary work.

### 5. PRECAUTIONS WHEN PERFORMING STATIONARY WORK

- (1) Power to the implement must be transmitted safely.  
The drive belt must be protected with a suitable cover to prevent accidents.  
Never use the protruding hardware to connect the belt.  
Stop the engine before handling the belt.
- (2) The implement must be securely installed, with necessary space provided for operator.
- (3) In case of indoor work, provide suitable ventilation and illumination.  
The internal combustion engine puts out poisonous exhaust gas. Good ventilation is essential while performing indoor work.

### 6. RIDING ON THE TRACTOR

- (1) Do not normally permit another person to ride on the tractor and implement.  
If seats for additional persons are provided, however, additional persons may get on the machine.



- (2) Do not allow other persons on the implement when traveling on a public road.
- (3) Do not leave the operator's seat when driving the tractor.
- (4) Do not get off or get on the tractor while it is moving, except in an emergency situation.

## 7. OPERATIONG PRECAUTIONS

- (1) Persons too young to be granted a driver's license must not operate the tractor.
- (2) Do not stand near the machine while it is in operation.
- (3) Operate the machine in accordance with instruction to prevent accidents.  
Do not allow other persons to stand near the working fields, especially during rotary tilling.
- (4) Precautions concerning starting the machine and engine.
  - a. Before starting the engine, set the transmission lever to Neutral, and disconnect PTO power.
  - b. Before starting the engine indoors, confirm that there is sufficient ventilation.
  - c. Before starting the tractor, confirm that the transmission gear is set to the proper speed, and that no one is standing near the machine.  
Confirm that the implement is securely mounted.
- (5) Precautions during operation
  - a. Operate the machine sitting in the operator's seat. When leaving the tractor, park the machine on level ground, lowering the implement to the ground, and stopping the engine with the parking brake applied. If it is necessary to park the machine on a slope, do not forget to palce a block under the tire.
  - b. Do not operate the machine roughly.

- Avoid traveling at extremely high speeds. Sudden starting, full acceleration, sudden braking and sharp turns must be avoided.
- c. Always look in the direction you are heading to avoid accidents.
  - d. While traveling at high speed, avoid full braking to the extent possible.  
Sudden braking while the machine is turning a corner is very dangerous.
  - e. Do not carry a load on the tractor.
  - f. Do not touch the power train, rotating part and other dangerous parts.
  - g. Do not allow another person to stand near the machine, especially while the machine is turning.
  - h. When working at night, use sufficient illumination to assure safe operation.
  - i. When working with blades or sharp protruded parts, excercise extreme caution to prevent accidents.
- (6) Precautions while traveling on the road
    - a. Abide by traffic laws.
    - b. Do not interfere with other trafic.
    - c. Remove any implements having blades or sharp protrusions.  
Or, apply a suitable cover on them.
    - d. Slow down machine speed on rough or curved roads.
    - e. Interlock both left and right brake pedals.
    - f. When mounting an implement wider than the tractor width, put red caution flags (red lamps at night) on both rear sides of the implement  
Attach a caution sign saying 'GO SLOW' on the rear of the machine to attract attention of other vehicle drivers.  
Operate the tractor carefully to prevent accidents. If

- a foldable implement is mounted, it should be folded.
- g. When passing an intersection or railway crossing, look both ways to confirm that it is safe to proceed.
- (7) Under poor working conditions
- a. Before starting work on rough terrain or in bad weather, plan your working schedule and method carefully.
- b. On poor footing, slow down the machine speed as much as possible. Operate the tractor carefully.
- c. When starting the tractor on an ascending slope, or when getting out of a deep groove, first set the transmission speed to the proper speed to attain required driving power.
- d. Do not shift the transmission when ascending a slope.
- e. When descending a decline, reduce speed.  
Do not run the tractor with the clutch disengaged or with the transmission in Neutral.
- f. When going down a slope, use the engine brake as much as possible.  
When starting the tractor on an up-slope, do not allow the front tires to float.
- g. When running on a steep slope, move the machine at an angle to decrease the inclination of the machine. Lower the position of the implement as much as possible to lower the center of gravity. Avoid driving into holes or grooves.  
Avoid turning the machine suddenly or sharply, to prevent the machine's turning over.
- h. When driving on a road where there is a channel full of water, check hardness of the footing near the channel.  
When driving on a slanted road, operate the machine carefully to prevent side-slip.

- i. When traversing a trench or furrow, or on soft hardpan, slow down machine speed to prevent tire slipping or turning over of the machine.
- j. If the tractor is caught in a channel or soft hardpan, study the situation to determine the best way to get out.  
Never hurry to remove the implement and balance weight. When these parts are removed, operate the machine carefully to prevent its turning over.
- k. When pulling a heavy load or removing a large root, move the tractor slowly until the pulling cable is fully extended. Then stop the machine and restart slowly. The pulling cable must be connected at a point lower than the center line of the rear axle.
- l. When loading or unloading the tractor on a truck or truck trailer, select loading boards of sufficient strength and specification.  
Carry out the work carefully.

## 8. PARKING AND STORING THE TRACTOR

- (1) When parking the tractor, select level and stable ground. Lower the implement to the ground. Remove the starter key. Apply the parking brake.
- (2) After each day's work, check and service the machine to assure trouble-free work on the next day.  
When a device using fire is required for work, inspect the device carefully.
- (3) When storing the tractor, set every functional part at the Stop position.  
Store the tractor indoors, or put on a cover for protection.  
When putting on a cover, wait until hot part, such as the muffler, have cooled down.

**10**

**ADDITIONAL INFORMATION**





## 1. RECOMMENDED LUBRICATION OIL CHART

### DIESEL ENGINE OIL *(Better than CB grade)*

ESSO LUBE HDX  
MOBIL DELVAC 1100 Series, 1200 Series  
SHELL ROTELLA S, SX, TX OIL

### GEAR OIL

ESSO GEAR OIL GP90  
MOBILUBE HD90  
SHELL SPIRAX HD90

### HYDRAULIC OIL

TERESSO 43  
MOBIL DTE OIL LIGHT  
SHELL TELLUS OIL 25

### LUBRICATING GREASE *(Lithium based multi-purpose grease)*

ESSO MULTI PURPOSE GREASE  
MOBIL GREASE MP  
SHELL ALVANIA GREASE 2

### ANTI-FREEZE SOLUTION

ESSO LONGLIFE COOLANT  
MOBIL PERMAZONE  
GLYCOSHELL PLUS

### FUEL

Diesel light oil of good quality

*NOTE: Necessary lubricant is filled at the factory.  
Use the above recommended lubricant or equivalent.*

## 2. IMPLEMENT LIST (Option)

	Name of Implement	Specifications	Application	Remarks
TRACTOR ACCESSORY	Trailer hitch 3-point link Bumper weight Front wheel weight	JIS-0 15kg x 3 17kg x 2 35kg x 2 (TX1500) 19kg x 2 (TX1000) TX1300	Towing a trailer Mounting the implement for 3P- link	2P bfacket  Common with TS series tractors For 4-wheel drive For 2-wheel drive
	Rear wheel weight Hydraulic power take out unit	19kg x 4 22kg x 2	Balancing the tractor  To increase traction  Change-over valve of Hydraulic fluid flow	
FERTILIZING	Lime sower (DTN-100T) Manure spreader (D-125T) Vacuum car (DK-500T) Broadcaster (BC-150, GH-150)	1000mm x 165 lit. 0.7 m <sup>3</sup> , with engine 500 lit.* 100 lit., 150 lit.	Spreading lime Spreading manure Spreading urine Spreading fertilizer, lime, and seeds	} Towed  3P
SUPPRESSING	Dry-field supressor (X101)	120cm + 30W	Supressing in upland field	Mount on the totary removing gauge wheel
WHEEL	Front supplemental wheel  Supplemental wheel  LK type wheel Float wheel Dia. wheel	500-12 (TX1300F, TX1500F)  7-14 (TX1000) 8-16 (TX-1300) 8-18 (TX1500)	When tilling swampy fields	} Fixed type (Nos. of lug – 5)  } Sliding type (Nos. of lug – 5)

	Name of Implement	Specifications	Application	Remarks
TILLING	Slick plow (YS)	10" ~ 12" x 1	Plowing in upland field or paddy.	3P
	Steel plow (S)	12" ~ 14" x 1 (TX1300 and TX1500 only)		
	Reversible 2-gang plow (TR-150F, TR150N) Volcanics plow (434V)	10" ~ 12" x 1 12" ~ 14" x 1 (TX1300 and TX1500 F only) 15 cm x 2 (4-wheel drive only) 12" x 1 (4-wheel drive tractor only)		
PUDDLING/HARROWING	Puddling rotor (X301-C)	95cm x 340mm dia. (TX1000)	Puddling by rotor	For side drive type
	Aux. puddling rotor	105cm x 340mm dia. (TX1300)		
	Puddling/leveller mounting stay	120cm x 340mm dia. (TX1500)		
	Rear skid for swampy fields	30cm x 340mm dia.		
	Spring leveller (1F-12) Puddling & levelling plate (X601)	120cm + 30W 120cm + 35W		
			When puddling by pulling wood at rear part of the rotary For use instead of gauge wheel in swampy fields Puddling and levelling	For center drive type Mounted on rotary

CULTI-  
VATING  
GRASS  
REMOVAL

TRANS-  
HAR-  
VEST-  
ING

TRANS-  
HARVEST-  
ING,  
LOADING,  
TRANSPORTING

	Name of Implement	Specifications	Application	Remarks	
RIDGING	Ridger (X501)	Bottom width- 12cm	Preparation of drainage Ridging for second crop in paddy fields	Mount on the rotary	
		" 13.5cm			
		" 18cm			
		" 21cm			
		One-side hiller (X501-R)	" 12cm	Riding for vegetable Multiple riding Ridging Prepaing drainage Ridging	Change rotary shaft (center drive) Mount on rotary blade shaft " (center drive)
		Rotary plow	390 mm dia.		
	Multiple rotary plows	390 mm dia.			
	Hilling blade (SPR-1)	450 mm dia.			
	Ridge-side rotor				
DISINFEC- TION TRANS- PLANTING	Soil disinfector		Disinfection of soil	3P	
	Rotary mulcher (LM-1500-H)		Mulching ridge with vinyl sheet (at the same time as rotary tilling)	Mount on rotary blade shaft (center drive)	
	Frail mower (NFZ-100)	110 cm	Removing grass Spreading grass removing solution	3P Towed	
	Digger (B-65)	Digging width - 65 cm	For bulbs and devil's tongue	3P	
	Trailer (DK-7A) Dump trailer (DK-70)	500 kg (TX1300 and TX1500)	Transportation	Towed	
GRASS HARVEST- ING, LOADING, TRANSPORTING	Rear mower (HM-143)	120 cm	Reaping grass Reaping and shreading Turning over and collecting grass	3P Towed, engine mounted. 3P	
	Forage harvester (FH-105GW)	60 cm			
	Tedder (HM-135)	5 ft			
	Docking loader bucket (DTX-13)	180 kg	Loading and transporting drops, grass, soil, etc. (HI-dump device included)	Mount on tractor body	
	Super manure fork	2 cylinders			
	HI-dump kit (TX13)				
HI-dump bucket					
HI-dump manure fork					
OTHERS	Canopy Carrier		Preventing sunshine Transportation	On operator's compartment	

### 3. SPECIFICATIONS

\* Specifications are subject to change without notice.

Specifications	Models						Remarks
	TX1000F 4 wheel drive	TX1000 2 wheel drive	TX1300F 4 wheel drive	TX1300 2 wheel drive	TX1500F 4 wheel drive	TX1500 2 wheel drive	
Dimensions (cm)							
Overall length	182		192	190	200	198	
Overall width	91		98		102		
Overall height	115		120		122.5		
Wheel base	118		122		128		
Wheel tread : Front	76.5	70	76.5	70	76.5	70	
: Rear	70, 80		74, 84		78, 88		
Min. ground clearance	25	31	27	33	27	35	
Min. turning radius							
Weight (kg)	478	448	510	484	537	508	
Engine							
Model	KE55		KE70		KE75		
Type	* Water-cooled, 4-cycle, 2-cylinder Diesel Engine						
Output (ps/rpm)	11/2700		13/2700		14.8/2700		
Displacement (ℓ)	0.544 *		0.669		0.764		
Bore x stroke (mm)	68 x 74		73 x 80		78 x 80		
Type of combustion chamber	Swirl chamber						
Method of lubrication	Forced circulation						
Method of cooling	Forced water-circulation						
Air cleaner	Dry						
Fuel : Type	Diesel light oil						
: Tank capacity (ℓ)	12						
Starting method	Starter motor (with glow plug)						
Battery	NS60						
Tractor							
Clutch	Dry, single disc						
Method of gear shifting	Selectable, sliding gear						
Differential gear	Bevel gear type, with dif-lock						
Brake	Mechanical, internal expanding type						
Steering gears	Ball screw type						



Specifications	Models						Remarks
	TX1000F 4 wheel drive	TX1000 2 wheel drive	TX1300F 4 wheel drive	TX1300 2 wheel drive	TX1500F 4 wheel drive	TX1500 2 wheel drive	
Tire : Front	5.00-12	4.00-9	5.00-12	4.50-10	5.00-12	4.00-12	
: Rear	7-14 (HL)		8-16 (HL)		8-18 (HL)		
Front axle	Center pin, Rumoan type (all 2-wheel drive) Center pin joint type (all 4-wheel drive) Central axle type						
Rear axle							
Implement lift Type Mounting : Rotary hoe : Trailing 3 point linkage Automatic control	Hydraulic controlled 2-P method Pin-locking type JIS-0 None						
Traveling speed (km/hr.)							
Forward	1	0.96*		1.10		1.17	
	2	1.50		1.71		1.82	
	3	2.48		2.83		3.01	
	4	4.37		4.99		5.32	
	5	6.81		7.76		8.27	
	6	12.08		13.79		14.69	
Reverse	1	1.27		1.44		1.54	
	2	5.74		6.55		6.98	
PTO shaft speed (rpm)							
	1			472			
	2			752			
	3			1177			





TOKYO, JAPAN

*FARM MACHINERY & EQUIPMENT*

**ISEKI & CO., LTD.**

Overseas Administrative Division

3, Kioi-cho, Chiyoda-ku, Tokyo, 102 Japan

Cable Address: ISEKIRICE TOKYO

Telex: 232-2752, 232-2753 Phone: (03) 238-5245~5258

*Printed in Japan*