



Parts Manual

Mfg. No: 38500B
Lawn Tractor (1998)

Model Components	Page
Chassis & Hood.....	4
Electrical System.....	8
Engine Mount.....	10
Motion Drive.....	12
Mower Housing.....	16
Mower Housing Suspension.....	20
Steering.....	22
Torque Specification Chart.....	24

Not For
In Reproduction

Chassis & Hood

Note: Unless noted otherwise, use the standard torque specifications

Mfg. No: 38500B

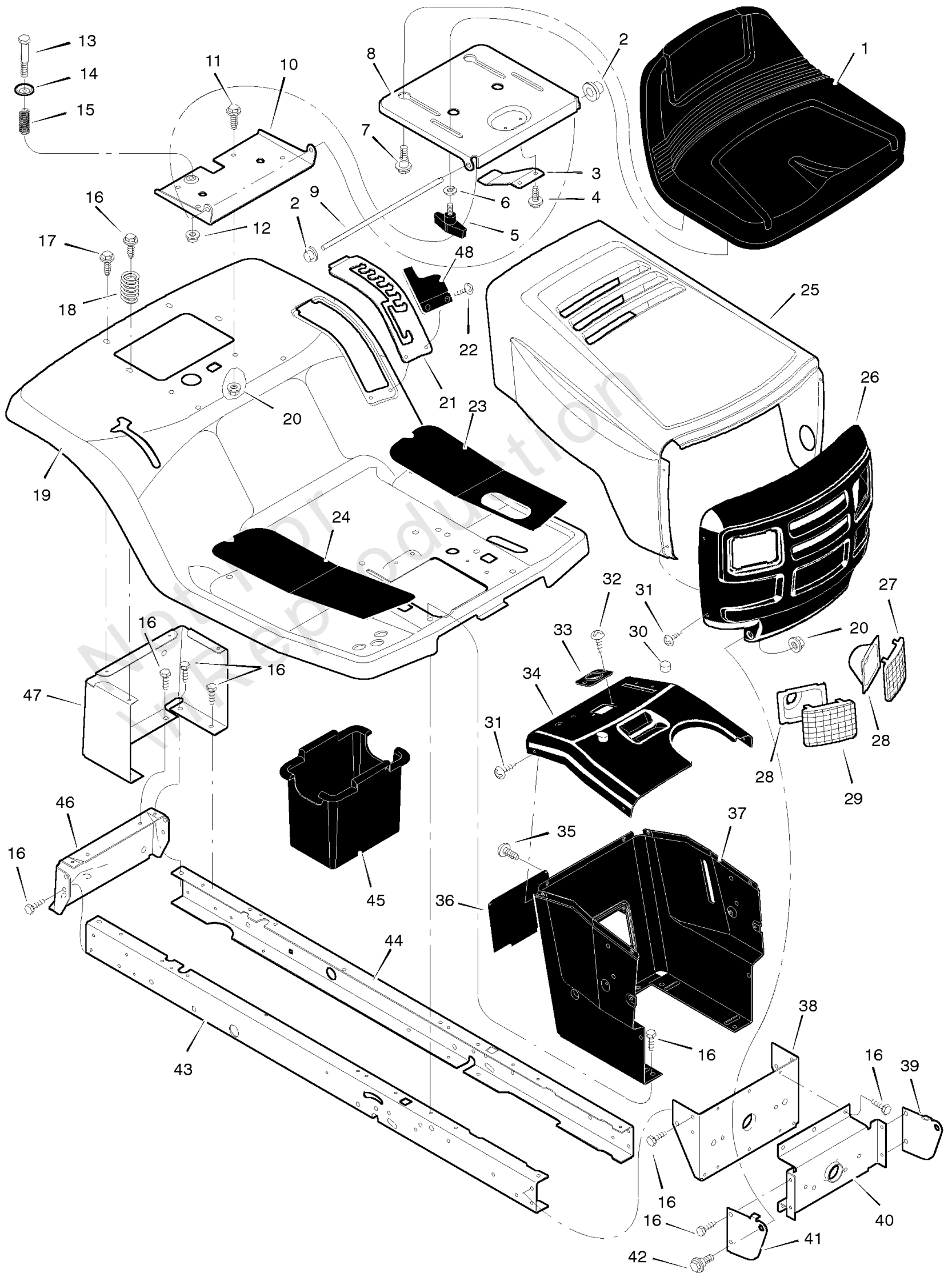

Chassis & Hood

REF NO	PART NO	QTY	DESCRIPTION
1	094162		Seat
2	028X23MA		Cap, Push On
3	094057MA		Spring
4	26X229MA		Screw
5	094160		Bolt, Wing
6	17X472		Washer
7	009X56MA		Bolt, Shoulder
8	094154E700		Support, Seat
9	094156ZMA		Rod, Pivot
10	094153E700MA		Bracket, Pivot
11	001X45MA		Bolt
12	015X89MA		Nut
13	009X55MA		Bolt, Shoulder
14	094155 Z		Washer
15	164X31		Spring
16	26X249MA		Screw
17	26X263MA		Screw
18	164X30MA		Spring
19	095249E276		Deck, Seat
20	015X88MA		Nut
21	094151E700		Plate, Index
22	009X47MA		Screw
23	094149		Mat, Left
24	094148		Mat, Right
25	94072E276		Hood
26	094079E701MA		Grille
27	094081MA		Lens, Left
28	094807 Z		Bezel
29	094080MA		Lens, Right
30	-----		UNKNOWN
31	26X270		Screw
32	26X239MA		Screw
33	094075		Bearing, Steering
34	094074E700		Dash
35	26X250MA		Screw
36	093007E701MA		Panel, Access
37	095318E701MA		Support, Dash
38	094013E701MA		Bracket, Rear Hanger
39	094083E700		Support, Left Grille
40	094007E701MA		Axle, Hanger
41	094082E700		Support, Right Grille
42	009X51MA		Bolt, Shoulder
43	94000E700		Frame, Right
44	94001E700		Frame, Left
45	094069		Container, Battery
46	1001002E701		Plate, Hitch
47	094023E700		Panel, Rear
48	094610MA		Cover
--	44X6276		Decal, Right Hood
--	44X6275		Decal, Left Hood
--	44X7325MA		Decal, Warning

Chassis & Hood

Note: Unless noted otherwise, use the standard torque specifications

Mfg. No: 38500B

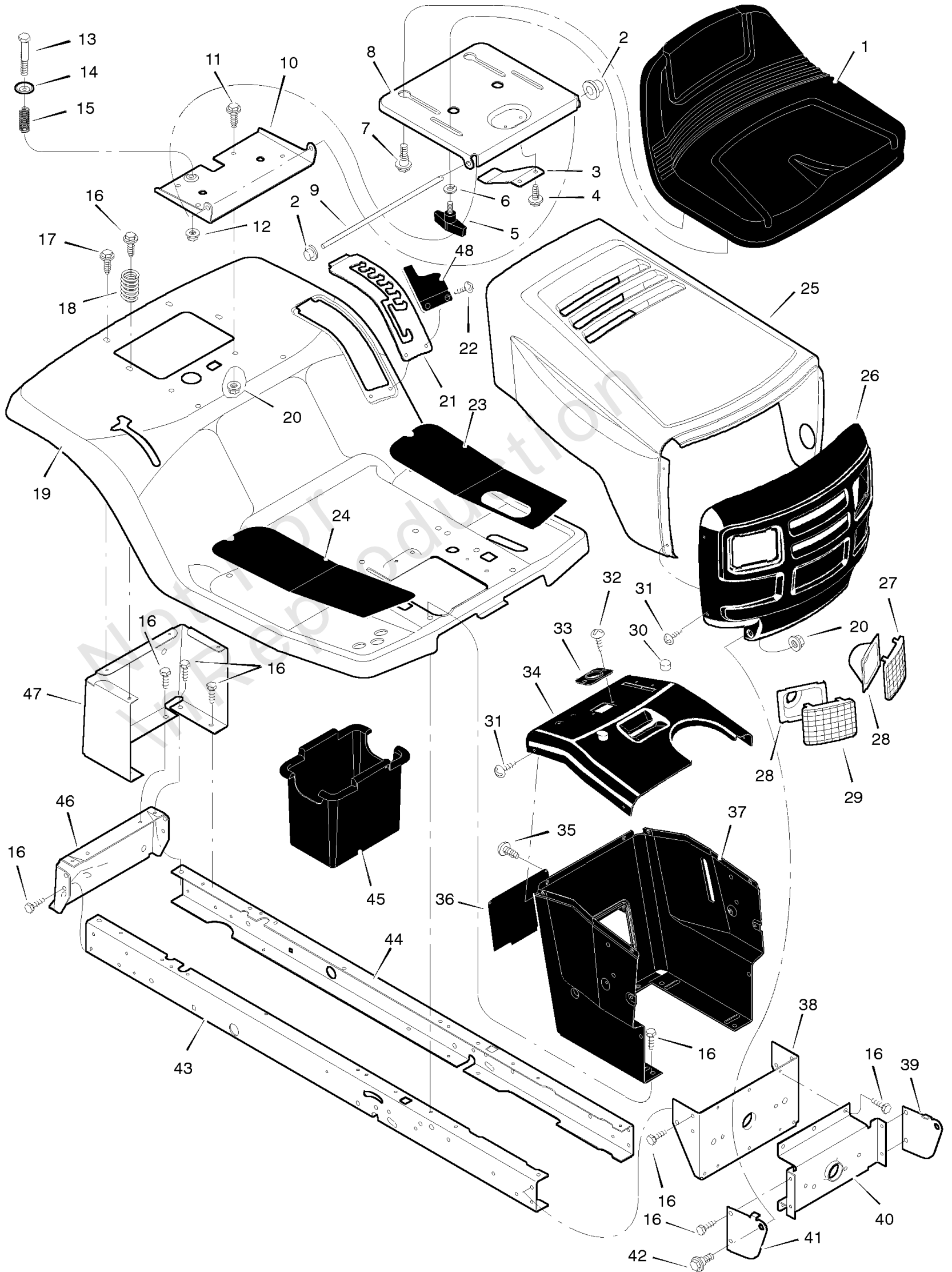

Chassis & Hood

REF NO	PART NO	QTY	DESCRIPTION
--	44X6278		Decal, Shifter
--	F-98772		Book, Instruction
--	F-98773		Parts List

Not For In Reproduction

Electrical System

Note: Unless noted otherwise, use the standard torque specifications

Mfg. No: 38500B

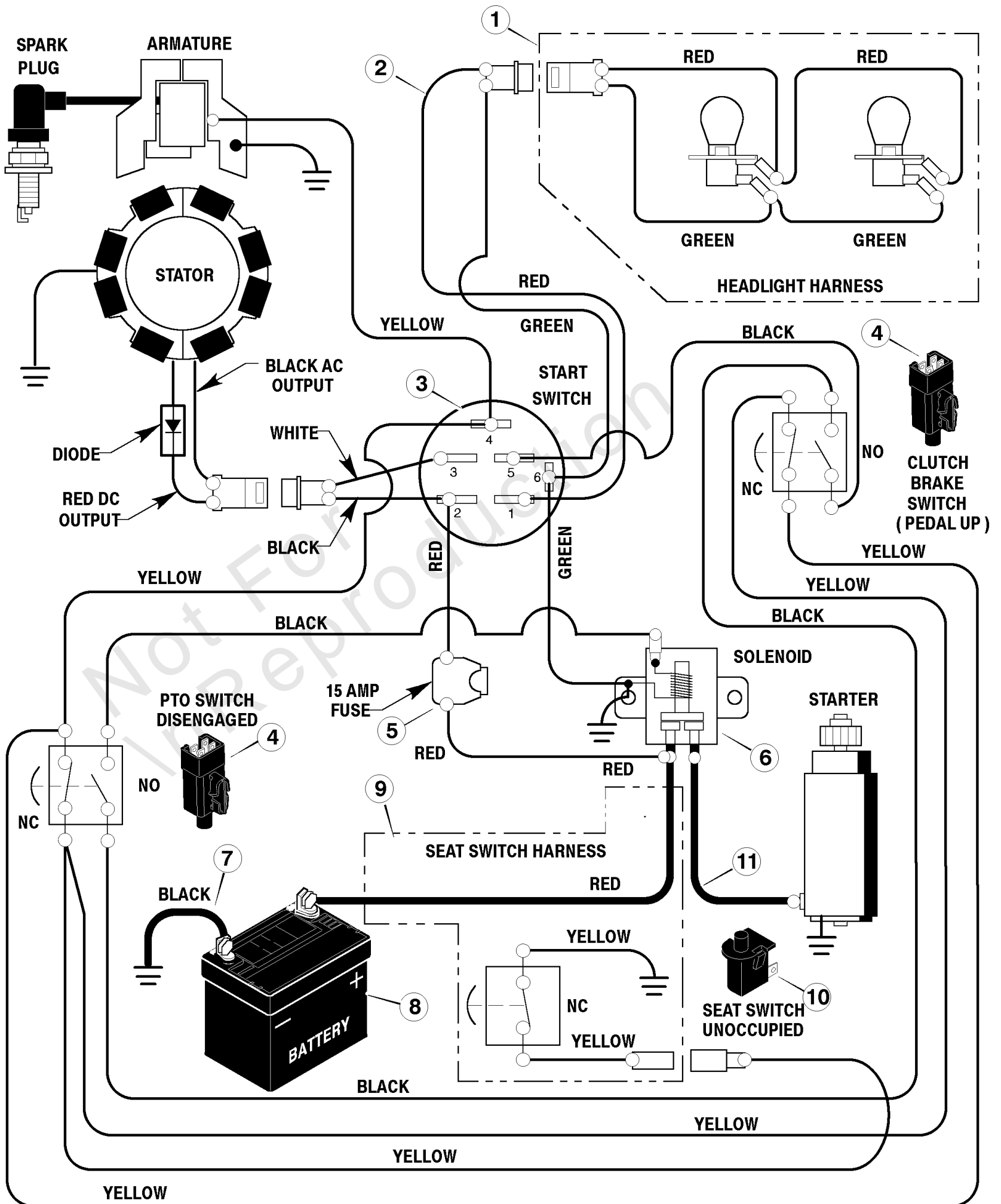

Electrical System

REF NO	PART NO	QTY	DESCRIPTION
1	250X68		Harness, Light Wire
--	092372		Socket, Light
--	090084MA		Bulb, Light
2	250X86MA		Harness, Chassis Wire
3	092377MA		Switch, Ignition
--	020729		Key, Ignition
--	091489MA		Nut, Hex
--	091488		Cap, Ignition
4	094136MA		Switch, Limit
5	054212		Fuse
--	407078MA		Holder, Fuse
6	094613		Solenoid
--	26X229MA		Screw, Mounting
--	15X116MA		Locknut
7	024X32MA		Cable, Battery Ground
--	26X213MA		Screw, Ground Cable
8	021075		Battery
--	002X82MA		Bolt, Carriage
--	014X79MA		Wingnut
9	250X67MA		Harness, Seat Switch Wire
10	094159MA		Switch, Seat Sensor
11	024X31MA		Cable

Engine Mount

Note: Unless noted otherwise, use the standard torque specifications

Mfg. No: 38500B

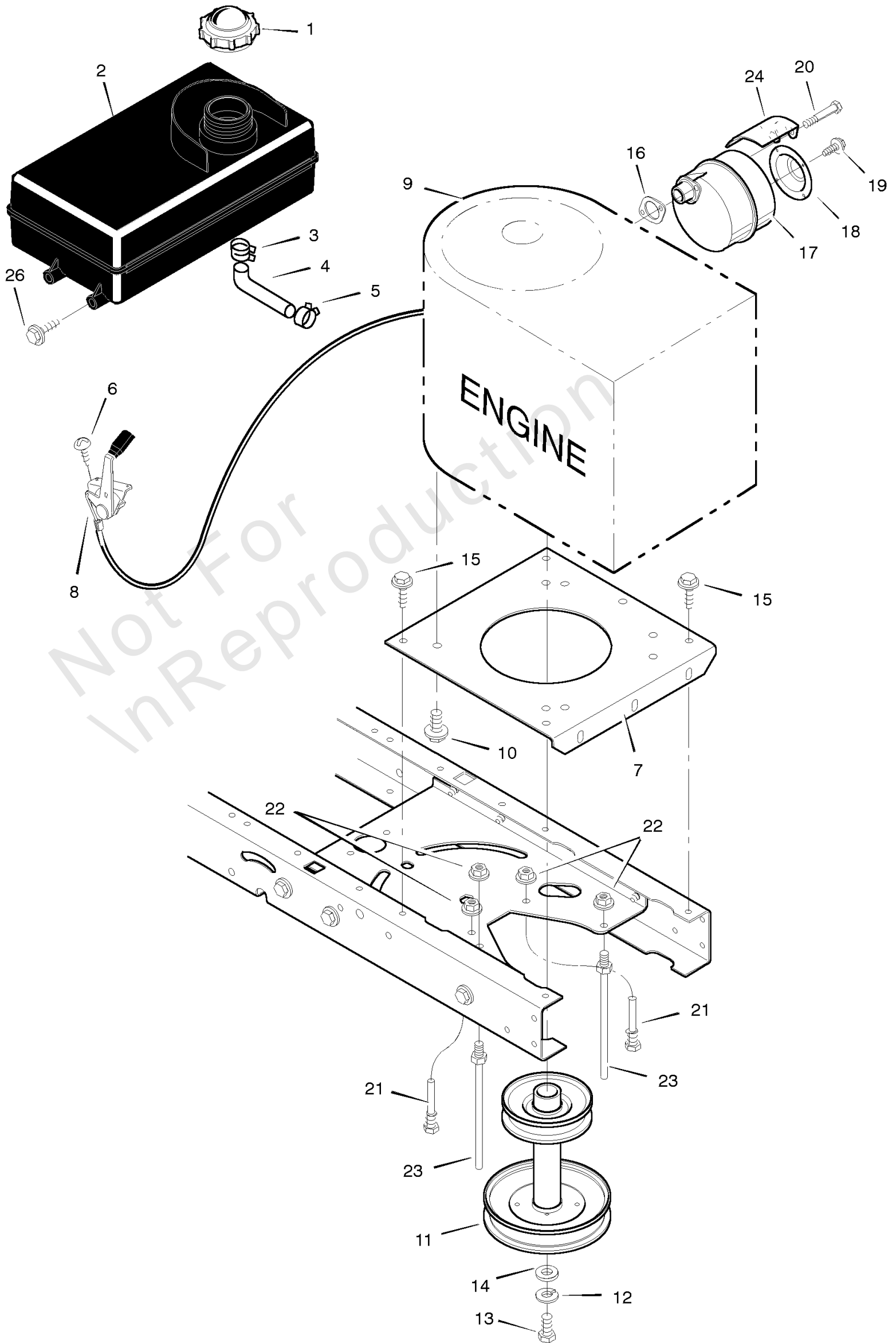

Engine Mount

REF NO	PART NO	QTY	DESCRIPTION
1	092317MA		Fuel Cap
2	7601092MA		TANK, Fuel 1.4 Gal.
3	095197MA		Hose Clamp
4	023717		Fuel Line
5	095197MA		Hose Clamp
6	26X201MA		Screw
7	094006E700		Plate, Engine
8	091989		Throttle Control
9	-----		Engine *
10	0025X7MA		Bolt, Engine Mount
11	094139 Z		Stack Pulley Assembly
12	019X35MA		Lockwasher
13	01X140MA		Bolt, Hex
14	17X170MA		Washer
15	26X249MA		Screw
16	692236		GASKET, Exhaust
17	091271		Muffler
18	094099 Z		Deflector, Muffler
19	26X208MA		Screw
20	01X134MA		Bolt, Hex
21	093349MA		Guide, Belt
22	15X792		Nut, Flange
23	094066MA		Guide, Belt
24	091277MA		Shield, Heat
26	26X253MA		Screw

Footnotes:

Note* Parts are available from an Authorized Service Center. See "Engines, Gasoline" or "Gasoline Engines" in the yellow pages of the telephone directory.

Motion Drive

Note: Unless noted otherwise, use the standard torque specifications

Mfg. No: 38500B

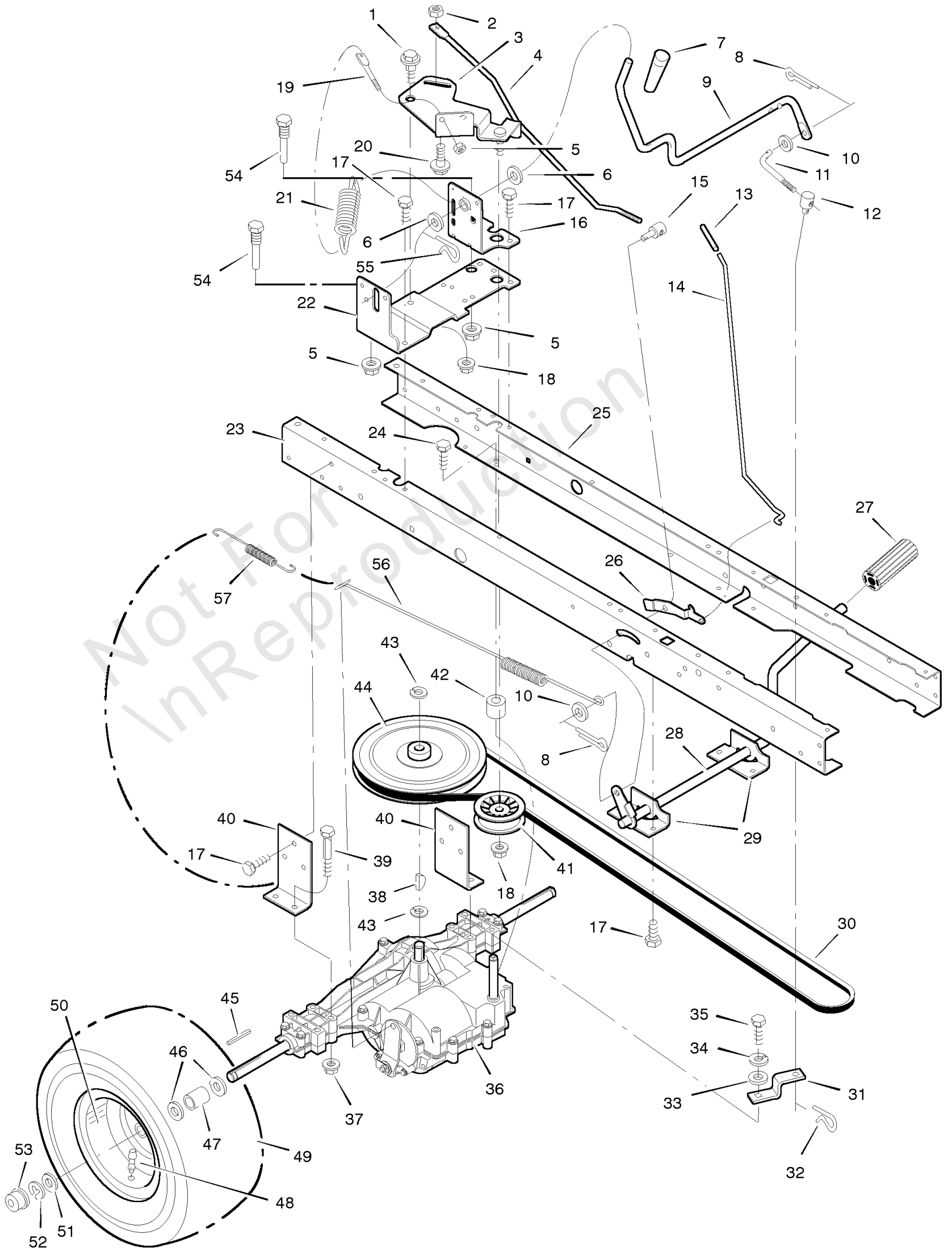

Motion Drive

REF NO	PART NO	QTY	DESCRIPTION
1	009X39MA		Bolt, Shoulder
2	015X89MA		Nut, Hex
3	094040 Z		Arm, Idler
4	094041 Z		Rod, Clutch
5	015X79MA		Nut
6	17X102MA		Washer
7	092697MA		Grip
8	030X20MA		Pin, Cotter
9	094043 Z		Lever, Shift
10	017X47MA		Washer
11	094044ZMA		Link, Shift
12	021920ZMA		Nut, Adjuster
13	091079MA		Grip
14	094152 Z		Rod, Parking Brake
15	094815ZMA		Nut, Adjuster
16	094034E700		Bracket, Shift
17	26X249MA		Screw
18	015X84MA		Nut
19	094042ZMA		Mount, Stud Spring
20	009X54MA		Bolt, Shoulder
21	165X116MA		Spring, Extension
22	094033E700		Bracket, Shifter
23	94000E700		Frame, Right
24	025X12		Screw
25	94001E700		Frame, Left
26	094045 Z		Latch, Parking Brake
27	021544MA		Pedal
28	094038E701MA		Lever, Brake/Clutch
29	094035E700		Bracket, Pedal
30	037X87MA		Belt, Motion Drive
31	094031ZMA		Yoke, Shift
32	0031X6MA		Pin, Hair
33	17X148MA		Washer
34	018X32MA		Washer
35	01X145MA		Bolt
36	-----		Transaxle **
37	015X88MA		Nut
38	020697MA		Key, Woodruff
39	01X155MA		Bolt
40	094008E701MA		Bracket, Transaxle
41	091179MA		Pulley
42	094132MA		Spacer
43	0011X7MA		E-Ring
44	095094MA		Pulley, Drive
45	021553MA		Key, Square
46	17X160MA		Washer
47	87X105 Z		Spacer, Transaxle
48	024373MA		Stem, Valve

Footnotes:

Note* When you order a tire, make sure to give the brand name of the tire so that the tread pattern on the tire will match.

Note** For information on Replacement Parts see the Central Parts Distributor on your area.

Motion Drive

Note: Unless noted otherwise, use the standard torque specifications

Mfg. No: 38500B

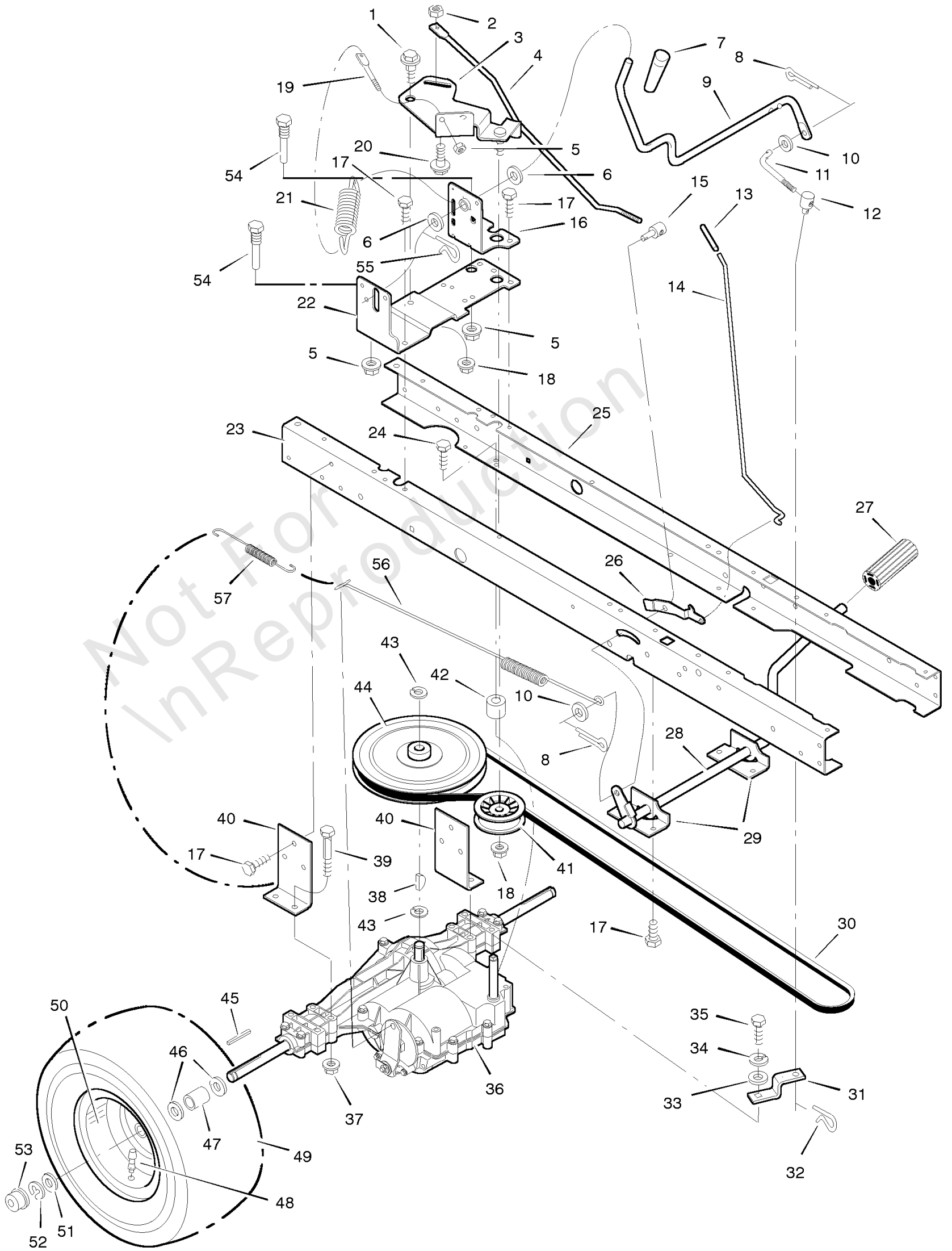

Motion Drive

REF NO	PART NO	QTY	DESCRIPTION
49	091923MA		Tire *
--	407049MA		Tube
50	0 92288601		Wheel & Tire Assembly
51	17X195MA		Washer
52	0011X3MA		E-Ring
53	094618MA		Hub Cap
54	093349MA		Guide, Belt
55	0031X4MA		Pin, Hair
56	165X115MA		Spring, Extension
57	165X92MA		Spring, Extension

Not For
In Reproduction

Footnotes:

Note* When you order a tire, make sure to give the brand name of the tire so that the tread pattern on the tire will match.

Note** For information on Replacement Parts see the Central Parts Distributor on your area.

Mower Housing

Note: Unless noted otherwise, use the standard torque specifications

Mfg. No: 38500B

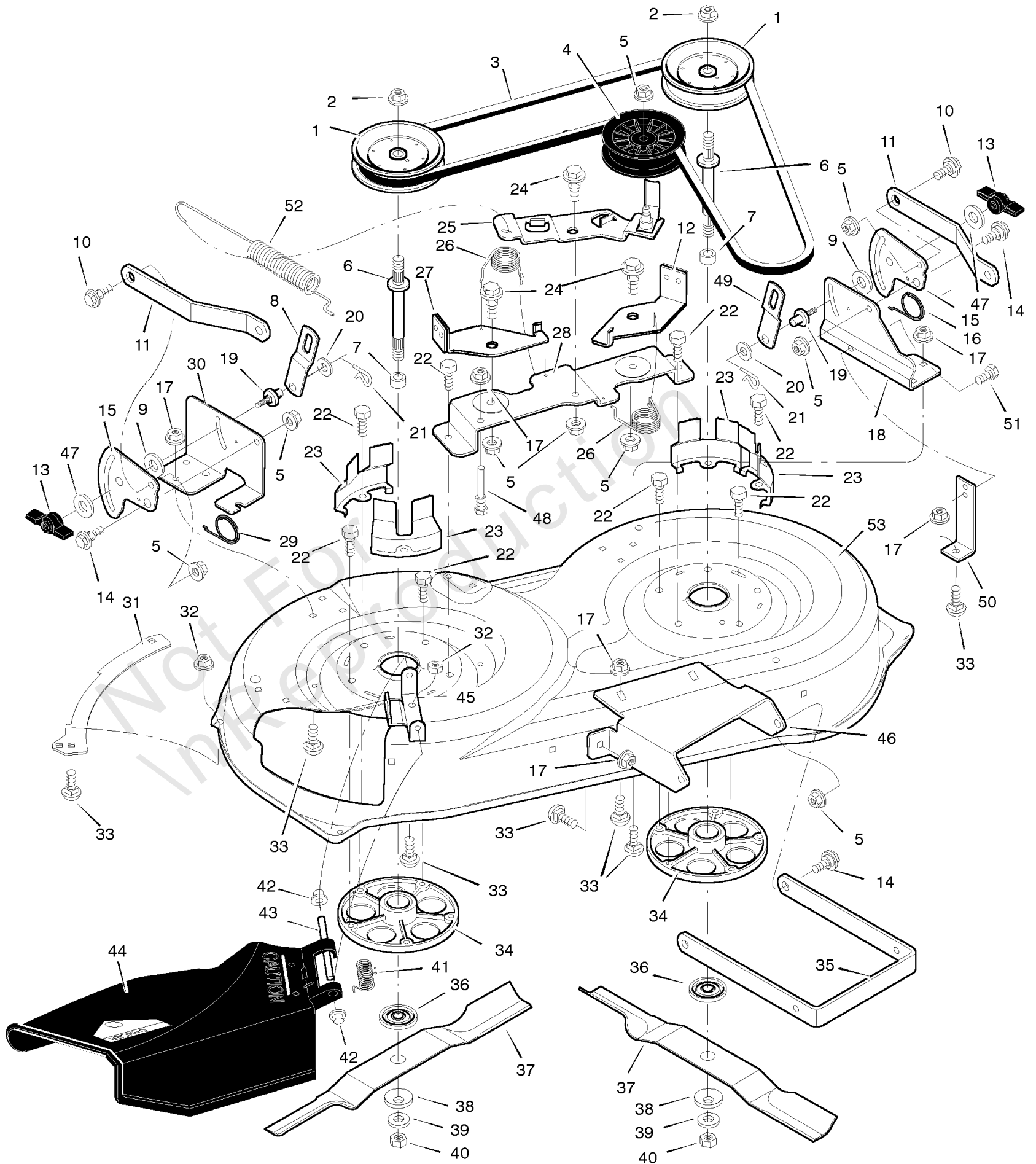

Mower Housing

REF NO	PART NO	QTY	DESCRIPTION
1	092852MA		Pulley, Jackshaft
2	15X121		Nut, Hex
3	037X86MA		Belt, Mower Drive
4	091801		Pulley, Idler
5	015X84MA		Nut, Flange
6	094129		Jackshaft
7	094130MA		Spacer
8	094053E701MA		Link, Right Lift
9	094137MA		Pad, Friction
10	009X52MA		Bolt, Shoulder
11	094055E701MA		Bracket, Suspension
12	094049E701MA		Pad Assembly, Left Brake
13	094068MA		Knob
14	009X51MA		Bolt, Shoulder
15	094128E700MA		Plate, Suspension
16	166X43MA		Spring
17	015X79MA		Nut, Flange
18	094054E700		Bracket, Suspension
19	094064		Pin, Hanger
20	17X103MA		Washer
21	0031X4MA		Pin, Cotter
22	0025X7MA		Bolt
23	094051E701MA		Cover, Pulley
24	009X39MA		Bolt, Shoulder
25	094177 Z		Arm, Idler
26	166X41MA		Spring
27	094047E701MA		Pad Assembly, Right Brake
28	094059E700MA		Bracket Assembly, Brake
29	166X42MA		Spring
30	094052E701		Bracket, Suspension
31	091770E700MA		Plate
32	015X88MA		Nut, Flange
33	002X53MA		Bolt, Carriage
34	090905		Housing, Jackshaft
35	690539E701MA		Bracket, Suspension
36	092466MA		Adapter, Blade
37	095104E701MA		Blade
38	17X166MA		Washer
39	17X165MA		Washer
40	15X100MA		Nut
41	0166X4MA		Spring
42	028X23MA		Cap, Push On
43	094957ZMA		ROD, Deflector
44	094707MA		Deflector
45	91765E700		Bracket, Deflector
46	094062E700		Bracket, Front Hanger
47	017X45 Z		Washer
48	094781MA		Guide, Belt
49	094611E701MA		Link, Left Lift
50	094681E700		Bracket, Support
51	26X249MA		Screw

Mower Housing

Note: Unless noted otherwise, use the standard torque specifications

Mfg. No: 38500B

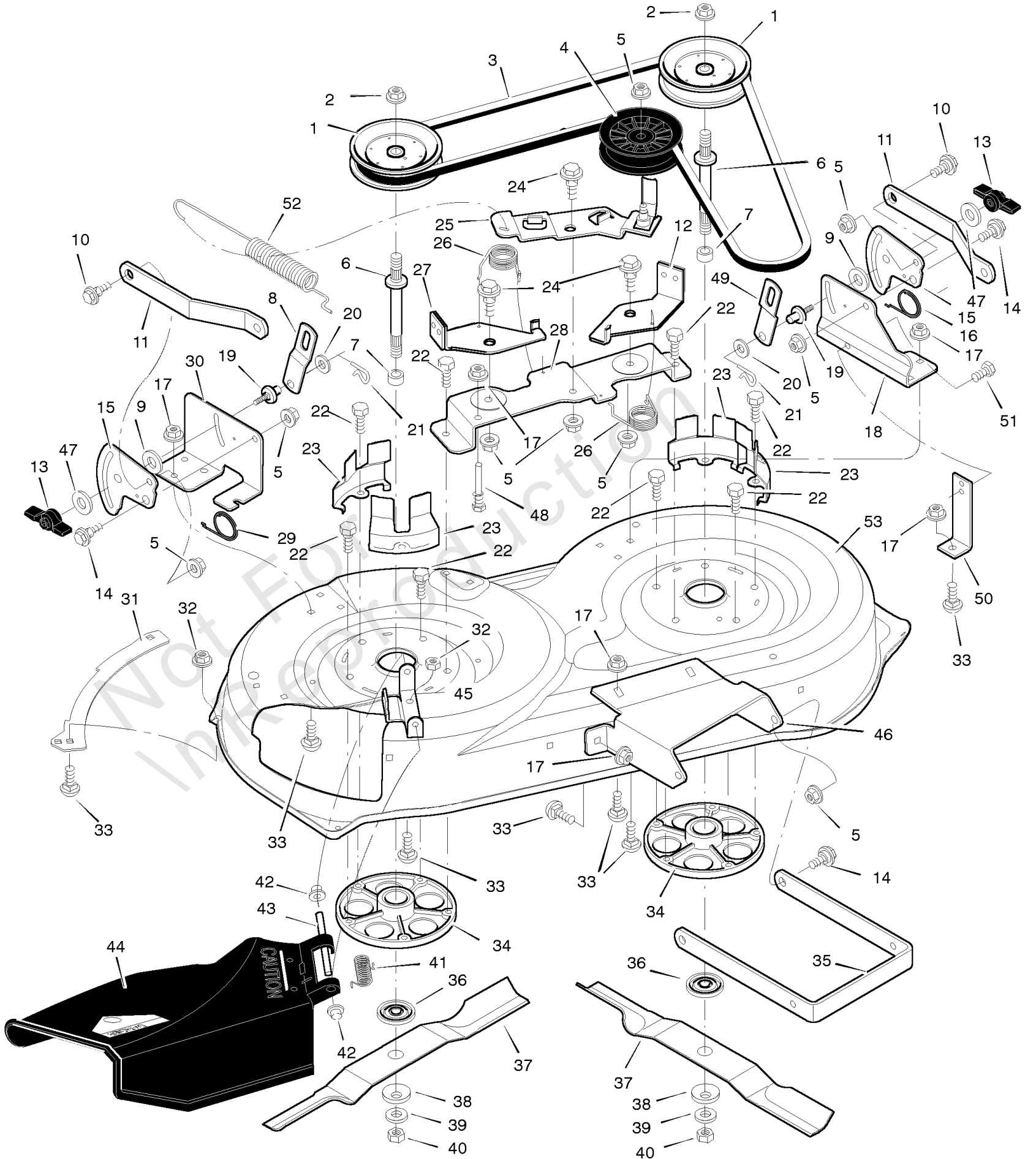

Mower Housing

REF NO	PART NO	QTY	DESCRIPTION
52	165X118MA		Spring, Extension
53	094061E701MA		Housing, Blade -(Includes Ref. No. 17, 18, 30, 31, 32, 33, 45, 46, 47 and 51)

Not For In Reproduction

Mower Housing Suspension

Note: Unless noted otherwise, use the standard torque specifications

Mfg. No: 38500B

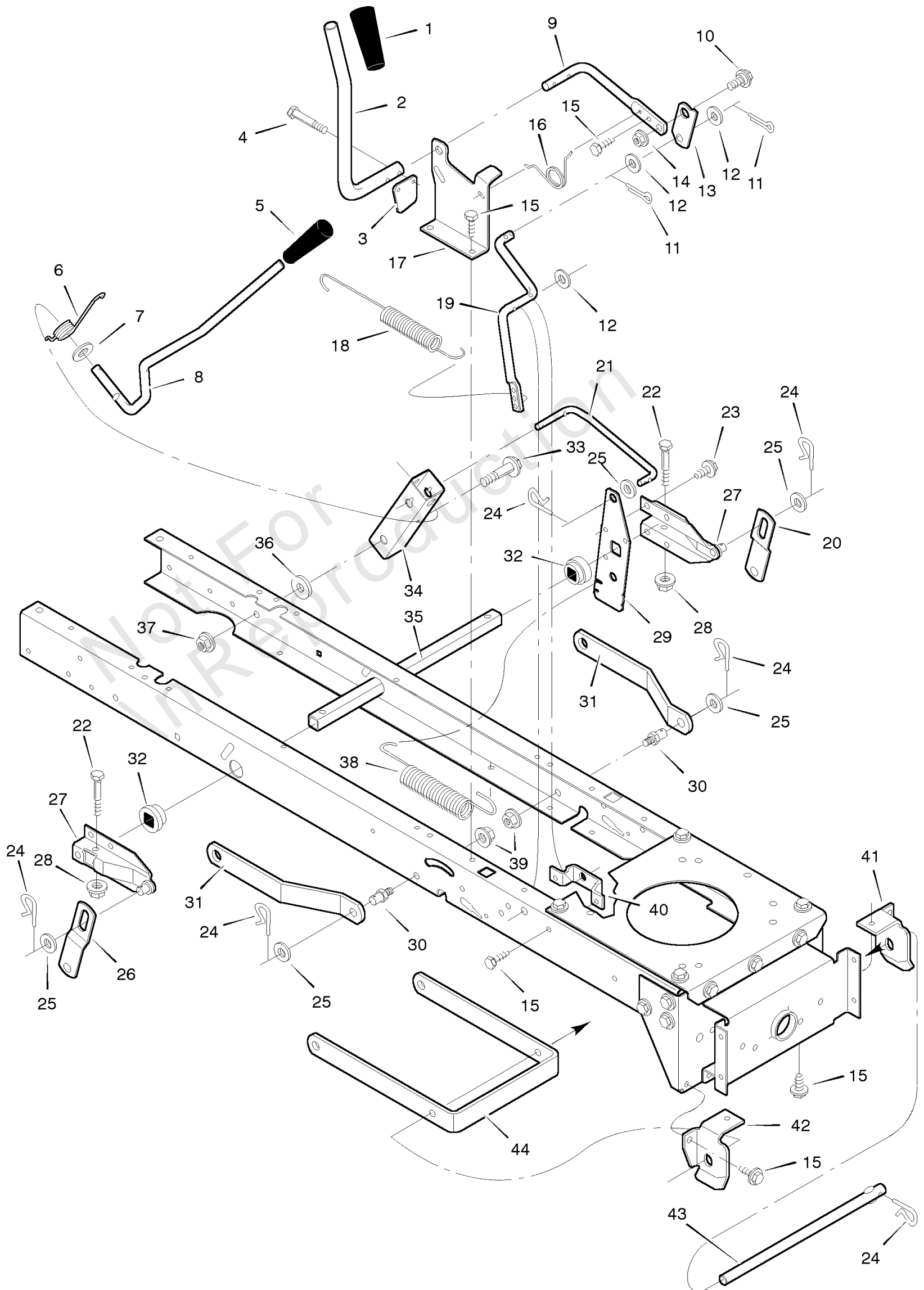

Mower Housing Suspension

REF NO	PART NO	QTY	DESCRIPTION
1	092698MA		Grip
2	094157 Z		Handle
3	094022 Z		Pad, Switch
4	0025X3MA		Screw, Hex
5	092697MA		Grip
6	166X40MA		Spring
7	17X103MA		Washer
8	690533MA		Lever, Lift
9	094017 Z		Lever, PTO
10	009X39MA		Bolt, Shoulder
11	030X20MA		Pin, Cotter
12	17X102MA		Washer
13	094004 Z		Link, PTO
14	015X84MA		Nut, Flange
15	26X249MA		Screw
16	166X39MA		Spring
17	094018E701MA		Bracket, PTO
18	165X118MA		Spring
19	94019E700		Crank, PTO
20	094611E701MA		Link, Left Lift
21	094028 Z		Link, Lift
22	001X74MA		Bolt
23	026X49MA		Screw
24	0031X4MA		Pin, Hair
25	017X91 Z		Washer
26	094053E701MA		Link, Right Lift
27	094180E700		Lever Assembly, Lift
28	15X118MA		Nut, Flange
29	094030E700		Plate, Lift Arm
30	094067MA		Pin
31	094055E701MA		Bracket, Rear Suspension
32	094065MA		Bushing
33	009X53MA		Bolt, Shoulder
34	094015E700		Bracket, Pivot
35	094063E700		Tube, Deck Lift
36	17X191MA		Washer
37	015X84MA		Nut, Flange
38	165X117MA		Spring
39	015X68MA		Nut, Flange
40	094005E700		Bracket, PTO
41	094027E701MA		Hanger, Left Deck
42	094026E701MA		Hanger, Right Deck
43	094158ZMA		Rod, Hanger
44	690539E701MA		Bracket, Suspension

Steering

Note: Unless noted otherwise, use the standard torque specifications

Mfg. No: 38500B

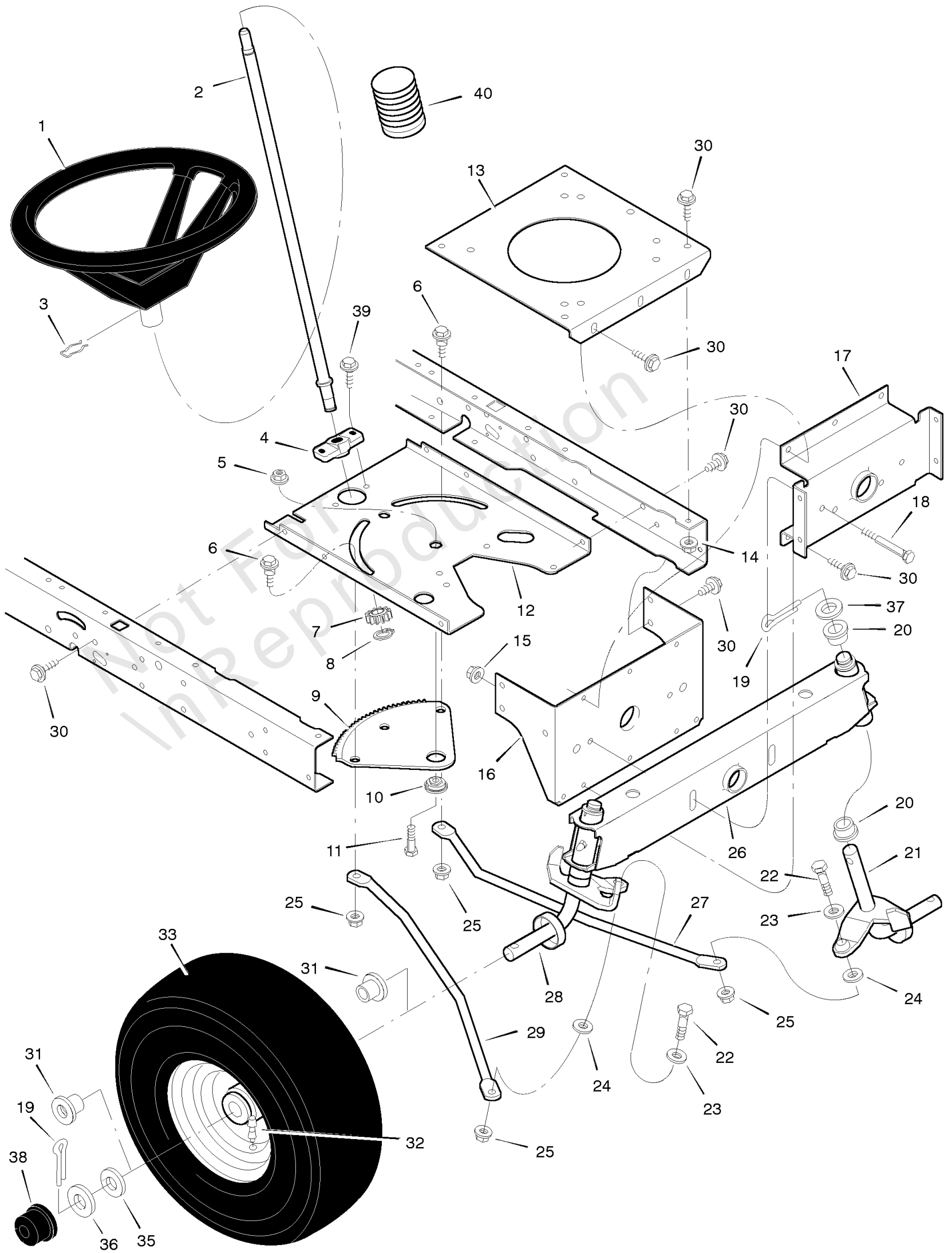

Steering

REF NO	PART NO	QTY	DESCRIPTION
1	094134MA		Wheel, Steering
2	094127		Post, Steering
3	094131MA		Clip, Retainer
4	094124MA		Bearing
5	15X113MA		Nut, Flange
6	009X57MA		Bolt, Shoulder
7	690183MA		Gear, Pinion
8	011X25MA		Ring, Snap
9	094121MA		Gear, Sector
10	094123MA		Bearing
11	001X84MA		CAPSCREW, Hex Head, 5/16-18 x 1
12	094003E700		Plate, Steering
13	094006E700		Plate, Engine
14	015X88MA		Nut, Flange
15	15X118MA		Nut, Flange
16	094013E701MA		Bracket, Hanger
17	094007E701MA		Axle, Hanger
18	01X146MA		Bolt
19	030X49MA		Pin, Cotter
20	092527MA		Bearing
21	094576E701MA		Spindle Assembly, Left
22	01X111MA		Bolt
23	17X104MA		Washer
24	017X53 Z		Washer
25	015X84MA		Nut, Flange
26	94012E700		Axle Assembly
27	94021E700		Drag Link, Left
28	094575E701MA		Spindle Assembly, Right
29	94020E700		Drag Link, Right
30	26X249MA		Screw
31	091334		Bearing, Wheel
32	024373MA		Stem, Valve
33	091912MA		Tire *
--	407047MA		Tube
34	094578601		Wheel and Tire Assembly
35	17X195MA		Washer
36	17X192MA		Washer
37	17X113MA		Washer
38	094618MA		Hub Cap -(Optional)
39	26X267MA		Screw
40	092059MA		Bellows -(Optional)

Footnotes:

Note* When you order a tire, make sure to give the brand name of the tire so that the tread pattern on the tire will match.

Hardware Identification & Torque Specifications

Torque Specification Chart								
FOR STANDARD METRIC MACHINE HARDWARE (Tolerance ± 20%)								
Property Class	5.6		8.8		10.9		12.9	
	Class 5.6		Class 8.8		Class 10.9		Class 12.9	
Size Of Hardware	in/lbs	Nm.	in/lbs	Nm.	in/lbs	Nm.	in/lbs	Nm.
	ft/lbs		ft/lbs		ft/lbs		ft/lbs	
M3	5.88	.56	13.44	1.28	19.2	1.80	22.92	2.15
M4	13.44	1.28	30.72	2.90	43.44	4.10	52.56	4.95
M5	26.4	2.50	60.96	5.75	5.97	8.10	7.15	9.7
M6	44.64	4.3	7.3	9.9	10.3	14	12.1	16.5
M7	5.2	7.1	12.1	16.5	16.9	23	19.9	27
M8	7.7	10.5	17.7	24	25	34	29	40
M10	15	21	35	48	50	67	59	81
M12	26	36	61	83	86.2	117	103	140
M14	42	58	101	132	136	185	162	220
M16	64	88	147	200	210	285	250	340
M18	89	121	202	275	287	390	346	470
M20	126	171	290	390	405	550	486	660
M22	169	230	390	530	559	745	656	890
M24	217	295	497	375	708	960	840	1140
M27	320	435	733	995	1032	1400	1239	1680
M30	435	590	995	1350	1401	1900	1681	2280
M33	590	800	1349	1830	1902	2580	2278	3090
M36	759	1030	1740	2360	2441	3310	2935	3980
M39	988	1340	2249	3050	3163	4290	3798	5150

Torque Specification Chart						
FOR STANDARD MACHINE HARDWARE (Tolerance ± 20%)						
Hardware Grade	No Marks		SAE Grade 5		SAE Grade 8	
	SAE Grade 2		SAE Grade 5		SAE Grade 8	
Size Of Hardware	in/lbs	Nm.	in/lbs	Nm.	in/lbs	Nm.
	ft/lbs		ft/lbs		ft/lbs	
8-32	19	2.1	30	3.4	41	4.6
8-36	20	2.3	31	3.5	43	4.9
10-24	27	3.1	43	4.9	60	6.8
10-32	31	3.5	49	5.5	68	7.7
1/4-20	66	7.6	8	10.9	12	16.3
1/4-28	76	8.6	10	13.6	14	19.0
5/16-18	11	15.0	17	23.1	25	34.0
5/16-24	12	16.3	19	25.8	29	34.0
3/8-16	20	27.2	30	40.8	45	61.2
3/8-24	23	31.3	35	47.6	50	68.0
7/16-14	30	40.8	50	68.0	70	95.2
7/16-20	35	47.6	55	74.8	80	108.8
1/2-13	50	68.0	75	102.0	110	149.6
1/2-20	55	74.8	90	122.4	120	163.2
9/16-12	65	88.4	110	149.6	150	204.0
9/16-18	75	102.0	120	163.2	170	231.2
5/8-11	90	122.4	150	204.0	220	299.2
5/8-18	100	136	180	244.8	240	326.4
3/4-10	160	217.6	260	353.6	386	525.0
3/4-16	180	244.8	300	408.0	420	571.2
7/8-9	140	190.4	400	544.0	600	816.0
7/8-14	155	210.8	440	598.4	660	897.6
1-8	220	299.2	580	788.8	900	1,244.0
1-12	240	326.4	640	870.4	1,000	1,360.0

The guides and ruler furnished below are designed to help you select the appropriate hardware.



Nut, M8

Thread Diameter (mm)

Inside Diameter (in) Threads per inch

Nut, 1/2-16



Screw, M8- 1.25 x 25

Thread Diameter (mm) Distance between threads (mm) Body Length (mm)

Body Diameter Threads per inch Body Length (in)

Screw, 1/2- 16 x 2



Standard Hardware Sizing

When a washer or nut is identified as 1/2" (M8), this is the *Nominal size*, meaning the *inside diameter* is 1/2 inch (8mm metric thread diameter); if a second number is present it represents the *threads per inch* (distance between threads).

When bolt or capscrew is identified as 1/2 - 16 x 2" (M8 - 1.25 x 50), this means the *Nominal size*, or body diameter is 1/2 inch (8mm metric thread diameter), the second number, 16, represents the *threads per inch*, (*distance between threads*). The final number is the body length of the bolt or screw, 2 inches (50mm).

NOTES

- These torque values are to be used for all hardware excluding: locknuts, self-tapping screws, thread forming screws, sheet metal screws and socket head setscrews.
- Recommended seating torque values for locknuts:
 - for prevailing torque locknuts - use 65% of grade 5 torques.
 - for flange whizlock nuts and screws - use 135% of grade 5 torques.
- Unless otherwise noted on assembly drawings, all torque values must meet this specification.

Common Hardware Types

Hex Head Capscrew



Washer



Carriage Bolt



Hex Nut

Wrench & Fastener Size Guide

1/4" Bolt or Nut Wrench—7/16"	5/16" Bolt or Nut Wrench—1/2"	3/8" Bolt or Nut Wrench—9/16"	7/16" Bolt or Nut Wrench (Bolt)—5/8" Wrench (Nut)—11/16"	1/2" Bolt or Nut Wrench—3/4"
M6 Bolt or Nut Wrench—10mm	M8 Bolt or Nut Wrench—13mm	M10 Bolt or Nut Wrench—17mm	M12 Bolt or Nut Wrench—19mm	M14 Bolt or Nut Wrench—22mm

MURRAY®